

# ASC/3

Advanced System Controller

---

## ASC/3 Programming Manual

P/N 100-0903-001 Rev. 15

April 2014

**Software Version:**  
**ASC/3 – 2.59.00**  
**ASC/3-2070 – 22.59.00**  
**ASC/3-LX – 32.59.00**

## Warranty

Econolite Control Products, Inc. warrants, for a period as shown below, from date of shipment, all control equipment listed below to be free from defects in material or workmanship and to be of the kind and quality designated or specified in the contract. This warranty does not extend to products not manufactured or sold by Econolite. Econolite has the sole right to determine whether or not an item is covered under our warranty policy.

<b>Controller</b>	<b>Standard Warranty Period</b>
ASC3 Series Controller	2 years
Safetran ASC3-RM Series Controller	2 years
2070 Series Controller	2 years

Econolite is not responsible for damage caused by negligence, acts of God, or use of equipment in a manner not originally intended. Econolite's liability under this warranty shall not exceed the cost of correcting defects in the equipment. Upon the expiration of the warranty period, all such liability shall terminate.

## Service

Prior to returning a product, you should first consult with your local support team to make sure the product needs to be returned for repair. Occasionally, product that appears to need repair can be made operable by configuration changes.

To obtain service, whether under warranty or not, contact the Econolite Repair Department at [Repairs@Econolite.com](mailto:Repairs@Econolite.com) (phone 714-575-5566).

To return products for service:

1. Obtain a Repair Authorization (RA) number from the Repair Department. Supply them with model name/number, equipment serial number, description of the problem and date of installation. They will send you a confirmation email that has details about the product and includes shipping instructions and shipping address.
2. Pack the product in its original (or equivalent) shipping container and include the confirmation email.
3. Insure the package (or assume the risk of loss/damage during shipment).

For products that are out-of-warranty, to eliminate the delays inherent in the repair quoting process, we are developing a flat rate repair schedule to give you a repair quote immediately on first contact. If you agree with the quote, you will then be required to supply a purchase order or authorized credit card prior to return shipping.

## **Documentation**

Published: April 24, 2014

© Copyright 2014 by Econolite Group, Inc. ALL RIGHTS RESERVED

Econolite Control Products Inc. provides this manual for its licensees and customers. No part of this manual may be reproduced, copied or distributed in any form without the prior written approval of Econolite Control Products Inc. The content of this manual is subject to change without notice.

## **Trademarks**

Econolite Control Products, Inc., the Econolite logo, and the *ASC/3* logo are registered trademarks of Econolite Control Products, Inc. in the United States and/or in other countries. All other trademarks are the property of their respective owners.

***For your notes:***



---

# Table of Contents

<b>Introduction</b> .....	<b>1-1</b>
<b>Purpose of this Manual</b> .....	<b>1-1</b>
<b>Contents of this Manual</b> .....	<b>1-2</b>
Chapters .....	1-2
Appendices .....	1-5
<b>Installation Procedures</b> .....	<b>2-1</b>
<b>Introduction</b> .....	<b>2-1</b>
ASC/3 Installation Instructions .....	2-1
2070 Installation Instructions .....	2-1
<b>ASC/3 Installation</b> .....	<b>2-2</b>
ASC/3 Preparation .....	2-2
ASC/3 Cable Connectors and Part Numbers .....	2-4
ASC/3 Environmental Operation Specifications .....	2-4
ASC/3 OS Support .....	2-5
ASC/3 Software Installation .....	2-5
ASC/3 Storage/Shipping .....	2-5
<b>2070 Installation</b> .....	<b>2-6</b>
2070 Hardware Requirements .....	2-6
ASC/3-2070 or ASC/3-LX Software Installation .....	2-6
<b>Supporting Windows Applications</b> .....	<b>2-7</b>
<b>Equipment Descriptions</b> .....	<b>3-1</b>
<b>Introduction</b> .....	<b>3-1</b>
<b>ASC/3 Controllers, General Features</b> .....	<b>3-2</b>
Equipment Enclosure Features .....	3-3
Central Processing Unit (CPU) .....	3-3
Power Supply .....	3-3

<b>ASC/3 System Operating Characteristics</b> .....	<b>3-4</b>
<b>ASC/3 Inputs/Outputs</b> .....	<b>3-4</b>
ASC/3-1000 and ASC/3-RM 1000 (TS2-T1 only) Connector .....	3-5
ASC/3-2100 Connectors .....	3-5
ASC/3-RM (C1) Connectors .....	3-5
<b>The 2070 Family</b> .....	<b>3-5</b>
2070 L .....	3-5
2070 LN .....	3-6
2070 ITS .....	3-7
2070 Modules .....	3-8
<b>ASC/3 NEMA &amp; 2070 HW Differences</b> .....	<b>3-9</b>
<b>Keypads and Displays for ASC/3 and 2070</b> .....	<b>4-1</b>
<b>Introduction</b> .....	<b>4-1</b>
Keypads .....	4-1
Liquid Crystal Displays (LCDs) .....	4-2
<b>ASC/3-Specific Functions and Display</b> .....	<b>4-2</b>
ASC/3 LCD Screen .....	4-2
ASC/3 Function and Numeric Keypads .....	4-2
<b>2070-Specific Functions and Display</b> .....	<b>4-3</b>
2070 LCD and Key Click .....	4-3
AUX Switch .....	4-4
2070 Keypads .....	4-4
2070 Keypad Overlay .....	4-5
2070 Display Contrast Adjust Knob .....	4-5
<b>ASC/3 &amp; 2070 Key Click and Backlight</b> .....	<b>4-6</b>
<b>ASC/3 &amp; 2070 Key Functions</b> .....	<b>4-6</b>
<b>MAIN MENU</b> or <b>A</b> .....	4-6
<b>SUBMENU</b> or <b>ESC</b> .....	4-7
<b>NEXT DATA</b> or <b>D</b> .....	<b>4-7</b>
<b>NEXT SCREEN</b> or <b>NEXT</b> .....	4-7
<b>NEXT PAGE</b> or <b>+</b> .....	4-8
<b>STATUS DISPLAY</b> or <b>E</b> .....	4-8
<b>HELP</b> or <b>F</b> .....	4-8
<b>SPEC FUNC</b> then <b>HELP</b> or <b>*</b> then <b>F</b> .....	4-9
Cursor Arrow Keys .....	4-9
<b>ENTER</b> or <b>ENT</b> .....	4-9
Number Keys <b>0</b> thru <b>9</b> .....	4-10

Alpha-Numeric Keys .....	4-10
Toggle Keys: <b>0,8</b> or <b>YES,NO</b> .....	4-11
Special Function, <b>SPEC FUNC</b> or <b>*</b> .....	4-11
<b>Clear</b> or <b>C</b> .....	4-12
Arrows for Screen Navigation .....	4-12
Call Simulation with the Keypad .....	4-12
Help, <b>HELP</b> or <b>F</b> .....	4-13
Exit .....	4-13
Front Panel Access Security .....	4-13
<b>MAIN MENU and Screen Navigation</b> .....	<b>5-1</b>
<b>Introduction</b> .....	<b>5-1</b>
<b>Main Menu</b> .....	<b>5-1</b>
Programming Summary .....	5-1
Display Screen Navigation .....	5-3
Horizontal Display Screen Scrolling .....	5-4
Vertical Display Screen Scrolling .....	5-4
Illustrations of the Full Screen .....	5-7
2070 and ASC/3 Fast Display Navigation .....	5-8
Hyperlink Field Navigation .....	5-9
Normally Inaccessible Screens .....	5-10
<b>Configuration</b> .....	<b>6-1</b>
<b>Transaction Mode</b> .....	<b>6-1</b>
Introduction .....	6-1
Changing Data with the Keypad .....	6-1
Changing Data with SNMP/STMP .....	6-3
Summary .....	6-3
<b>Automatic Backup to Datakey</b> .....	<b>6-4</b>
<b>Automatic Backup to Flash</b> .....	<b>6-4</b>
ASC/3 Backup .....	6-4
2070 Backup .....	6-4
<b>Configuration Submenu, MM-1</b> .....	<b>6-4</b>
<b>Controller Sequence Submenu, MM-1-1</b> .....	<b>6-5</b>
Programming Summary .....	6-5
Phase Ring Sequence and Assignment, MM-1-1-1 .....	6-6
Phase Compatibility, MM-1-1-2 .....	6-11
Backup Prevent Phases, MM-1-1-3 .....	6-12
Simultaneous Gap Phases, MM-1-1-4 .....	6-13

<b>Diamond Configuration Information</b> .....	<b>6-15</b>
<b>Phases in Use/Exclusive Pedestrian</b> .....	<b>6-16</b>
Phases in Use, MM-1-2 .....	6-16
Exclusive Pedestrian Timing, MM-1-2 .....	6-16
<b>Load Switch Assignment (MMU CHANNEL), MM-1-3</b> .....	<b>6-17</b>
<b>Port 1 (SDLC) Submenu, MM-1-4</b> .....	<b>6-20</b>
SDLC Options, MM-1-4-1 .....	6-20
MMU Compatibility Programming, MM-1-4-2 .....	6-24
Color Check Enable, MM-1-4-3 .....	6-28
Secondary Stations/Tests, MM-1-4-4 .....	6-29
<b>Programmable Communication Ports Submenu, MM-1-5</b> .....	<b>6-30</b>
Ethernet Port, MM-1-5-1 .....	6-30
Serial Communication Protocols .....	6-32
Port 2/C50S, MM-1-5-2 .....	6-34
Port 3A/C21S, MM-1-5-3 .....	6-35
Port 3B/C22S, MM-1-5-4 .....	6-36
Serial Port Parameters .....	6-38
NTCIP Parameters, MM-1-5-5 .....	6-42
ECPIP Parameters, MM-1-5-6 .....	6-44
<b>Enable Logging Submenu, MM-1-6</b> .....	<b>6-45</b>
Event Logging, MM-1-6-1 .....	6-45
<b>Display/Access Submenu, MM-1-7</b> .....	<b>6-49</b>
Administration, MM-1-7-1 .....	6-49
Display Options, MM-1-7-2 .....	6-53
Security Access, MM-1-7-3 .....	6-55
<b>Logic Processor Submenu, MM-1-8</b> .....	<b>6-59</b>
Logic Processor Statement Control, MM-1-8-1 .....	6-59
Logic Processor Statements, MM-1-8-2 .....	6-60
General Programming Notes for Logic Statements, MM-1-8-2 ...	6-60
<b>Extended Logic Processor Group</b> .....	<b>6-64</b>
Comment Statement .....	6-64
Message .....	6-64
Control Statements .....	6-65
<b>Controller</b> .....	<b>7-1</b>
<b>Controller Submenu, MM-2</b> .....	<b>7-1</b>
Programming Summary .....	7-1



Timing Plans, MM-2-1 .....	7-2
Vehicle Overlap, MM-2-2 .....	7-8
Vehicle or Pedestrian Overlaps, MM-2-3 .....	7-17
Guaranteed Minimum Times, MM-2-4 .....	7-19
Start/Flash Data, MM-2-5 .....	7-20
Option Data, MM-2-6 .....	7-30
Pre-Timed Mode, MM-2-7 .....	7-36
Recall Data, MM-2-8 .....	7-36
<b>Coordinator .....</b>	<b>8-1</b>
<b>Coordinator Submenu, MM-3 .....</b>	<b>8-1</b>
Programming Summary .....	8-1
<b>Coordinator Options, MM-3-1 .....</b>	<b>8-4</b>
Programming Summary .....	8-4
<b>Coordinator Pattern Data, MM-3-2 .....</b>	<b>8-16</b>
Programming Summary .....	8-17
<b>Added Parameters .....</b>	<b>8-32</b>
<b>Split Pattern, MM-3-3 .....</b>	<b>8-34</b>
Programming Summary .....	8-34
<b>Automatic Permissive Minimum Green, MM-3-4 .....</b>	<b>8-37</b>
<b>Split Demand, MM-3-5 .....</b>	<b>8-38</b>
<b>Preempt/TSP/SCP .....</b>	<b>9-1</b>
<b>Preempt Submenu, MM-4 .....</b>	<b>9-1</b>
Programming Summary .....	9-1
Preempt Plans 1-10, MM-4-1 .....	9-4
Preempt Filtering & TSP/SCP Mapping, MM-4-2 .....	9-28
TSP/SCP Plans 1-6, MM-4-3 .....	9-30
TSP/SCP Split Pattern, MM-4-4 .....	9-30
<b>Time Base .....</b>	<b>10-1</b>
<b>Time Base Submenu, MM-5 .....</b>	<b>10-1</b>
Programming Summary .....	10-1
Clock/Calendar Data, MM-5-1 .....	10-3
Creating an Action Plan, MM-5-2 .....	10-6
Creating a Day Plan, MM-5-3 .....	10-14
Day Plan Schedule, MM-5-4 .....	10-16
Exception Days, MM-5-5 .....	10-19

- Detectors** ..... 11-1
  - Detector Submenu, MM-6** ..... 11-1
    - Programming Summary ..... 11-1
  - Vehicle Detector Phase Assignment, MM-6-1** ..... 11-3
  - Vehicle Detector Setup, MM-6-2** ..... 11-6
  - Pedestrian and System Detector Options, MM-6-3** ..... 11-14
    - NTCIP Mode with MM-6-3 ..... 11-14
    - Econolite Mode with MM-6-3 ..... 11-15
  - Log Interval - Speed Detector Setup, MM-6-4** ..... 11-16
  - Vehicle Detector Diagnostics, MM-6-5** ..... 11-19
  - Pedestrian Detector Diagnostics, MM-6-6** ..... 11-21
- Status Displays** ..... 12-1
  - Introduction** ..... 12-1
  - Main Status Displays** ..... 12-2
  - Status Display Submenu, MM-7** ..... 12-15
    - Controller Status Display, MM-7-1** ..... 12-20
    - Coordinator Status Display, MM-7-2** ..... 12-27
    - Preemptor Status Display, MM-7-3-1** ..... 12-34
    - TSP/SCP Status Display, MM-7-3-2** ..... 12-44
    - Time Base Status Display, MM-7-4** ..... 12-54
    - Communications Submenu, MM-7-5** ..... 12-57
      - Ethernet Communication Status, MM-7-5-1 ..... 12-57
      - Ports 2/C50S, 3A/C21S, 3B/C22S Status ..... 12-58
      - NTCIP Status Screen, MM-7-5-5 ..... 12-63
      - ECPIP Status Screen, MM-7-5-6 ..... 12-64
      - IEEE 1570 Status, MM-7-5-7 ..... 12-65
    - Detector Status Display, MM-7-6** ..... 12-66
    - Flash/SDLC/MMU Status Display, MM-7-7** ..... 12-68
      - Flash Status Display, MM-7-7-1 ..... 12-68
      - SDLC (Port 1) Status, MM-7-7-2 ..... 12-75
      - MMU Status, MM-7-7-3 ..... 12-76
      - MMU Extended Status, MM-7-7-4 ..... 12-80
      - MMU AC Status, MM-7-7-5 ..... 12-82

MMU Compatibility Status, MM-7-7-6, ECPI Feature .....	12-84
<b>Input/Output Status Submenu, MM-7-8 .....</b>	<b>12-85</b>
Controller Inputs, MM-7-8-1 .....	12-85
Controller Outputs, MM-7-8-2 .....	12-86
Hardware Inputs, MM-7-8-3 .....	12-87
Hardware Outputs, MM-7-8-4 .....	12-88
Auxiliary Hardware I/O, MM-7-8-5 .....	12-89
T&F BIU I/O, MM-7-8-6 .....	12-90
D&R BIU I/O, MM-7-8-7 .....	12-90
I/O Differences Status, MM-7-8-9, ECPI Feature .....	12-91
<b>Utilities .....</b>	<b>13-1</b>
<b>Utilities Submenu, MM-8 .....</b>	<b>13-1</b>
Programming Summary .....	13-1
Copy/Clear Utility, MM-8-1 .....	13-2
USB Management, MM-8-2 .....	13-8
Print Utility, MM-8-3 .....	13-9
Transfer Utility, MM-8-4 .....	13-10
Sign-On Screen Utility, MM-8-5 .....	13-11
<b>Log Buffers Submenu, MM-8-6 .....</b>	<b>13-12</b>
Display Log Buffers Submenu, MM-8-6-1 .....	13-13
Print Log Buffers, MM-8-6-2 .....	13-14
Clear Submenu, MM-8-6-3 .....	13-15
<b>Software Modules, MM-8-7 .....</b>	<b>13-15</b>
<b>Diagnostics Information .....</b>	<b>14-1</b>
<b>Front Panel LED Indicator .....</b>	<b>14-1</b>
Tri-Color Mode (ASC/3-2100, 1000, RM) .....	14-1
Single-Color Mode (2070 Controller) .....	14-2
<b>Diagnostics Information, MM-9 .....</b>	<b>14-2</b>
Diagnostics Information, MM-9-1 .....	14-2
Warning Check Submenu, MM-9-2 .....	14-2
What is a Warning Check? .....	14-3
Context-Sensitive Warning .....	14-4
Enable Warning Check Categories, MM-9-2-1 .....	14-4
<b>Compile and View Active Warnings, MM-9-2-2 .....</b>	<b>14-5</b>
Edit/View Disabled Warnings, MM-9-2-3 .....	14-7
Startup Warning Message .....	14-8

- Appendix A - ASC/3, ASC/3-2070 & ASC/3-LX Menu Tree ..... A-1
- Appendix B - ASC/3 Screens ..... B-1
- Appendix C - Reserved ..... C-1
- Appendix D - Program Reference Card ..... D-1
  - ASC/3 Program Reference Card ..... D-1
  - Configuration Submenu ..... D-2
    - MM-1-1-1 Phase Ring Assignment (PRI = Priority) ..... D-2
    - MM-1-1-2 Phase Compatibility ..... D-6
    - MM-1-2 Phases In Use / Exclusive Ped ..... D-6
    - MM-1-1-3 Enable Backup Prevent ..... D-7
    - MM-1-1-4 Simultaneous Gap ..... D-7
    - MM-1-3 Phase-to-Load-Switch (MMU) Assignment ..... D-8
    - MM-1-4-1 SDLC Options ..... D-8
    - MM-1-4-2 MMU Program ..... D-9
    - MM-1-4-3 Color Check Enable ..... D-9
    - MM-1-4-4 Secondary Stations/Tests ..... D-9
    - MM-1-5-1 Ethernet Port Configuration ..... D-10
    - MM-1-5-2 ASC/3 Port 2 – 2070 C50S ..... D-10
    - MM-1-5-3 ASC/3 Port 3A – 2070 C21S ..... D-10
    - MM-1-5-4 ASC/3 Port 3B – 2070 C22S ..... D-10
    - MM-1-5-5 Global Port Parameters ..... D-11
    - MM-1-5-6 ECPIP ..... D-11
    - MM-1-6-1 Enable Event Logs ..... D-11
    - MM-1-7-1 Administration ..... D-12
    - MM-1-7-2 Display Options ..... D-12
    - MM-1-8-1 Logic Statement Control ..... D-12
    - MM-1-8-2 Logic Processor Statements ..... D-13
  - Controller Submenu ..... D-16
    - MM-2-1 Controller Timing Data, sheet 1 of 2 ..... D-16
    - MM-2-1 Controller Timing Data, sheet 2 of 2 ..... D-17
    - MM-2-2 Vehicle Overlaps, sheet 1 of 6 ..... D-18
    - MM-2-2 Vehicle Overlaps, sheet 2 of 6 ..... D-19
    - MM-2-2 Vehicle Overlaps, sheet 3 of 6 ..... D-20
    - MM-2-2 Vehicle Overlaps, sheet 4 of 6 ..... D-21
    - MM-2-2 Vehicle Overlaps, sheet 5 of 6 ..... D-22
    - MM-2-2 Vehicle Overlaps, sheet 6 of 6 ..... D-23
    - MM-2-3 Veh/Ped Overlaps ..... D-24
    - MM-2-4 Guaranteed Minimum Times ..... D-25

MM-2-5 Start/Flash Data .....	D-25
MM-2-6-1 Controller Options .....	D-26
MM-2-7 Pre-Timed Mode .....	D-26
MM-2-8 Phase Recall Options .....	D-27
<b>Coordinator Submenu .....</b>	<b>D-28</b>
MM-3-1 Coordinator Options .....	D-28
MM-3-2 Coordinator Pattern, sheet 1 of 2 .....	D-29
MM-3-2 Coordinator Pattern, sheet 2 of 2 .....	D-30
MM-3-3 Split Pattern, sheet 1 of 4 .....	D-31
MM-3-3 Split Pattern, sheet 2 of 4 .....	D-32
MM-3-3 Split Pattern, sheet 3 of 4 .....	D-33
MM-3-3 Split Pattern, sheet 4 of 4 .....	D-34
MM-3-4 Auto Permissive Minimum Green Time .....	D-35
MM-3-5 Split Demand .....	D-35
<b>Preemptor Submenu .....</b>	<b>D-36</b>
MM-4-1 Preemptor, sheet 1 of 2 .....	D-36
MM-4-1 Preemptor, sheet 2 of 2 .....	D-37
MM-4-2 Low Priority Preemptor Selection .....	D-38
MM-4-3 TSP/SCP Plan (Optional) .....	D-38
MM-4-4 TSP/SCP Split Pattern (Optional) .....	D-39
<b>Time Base Submenu .....</b>	<b>D-40</b>
MM-5-1 Clock/Calendar Data .....	D-40
MM-5-2 Action Plan, sheet 1 of 4 .....	D-40
MM-5-2 Action Plan, sheet 2 of 4 .....	D-41
MM-5-2 Action Plan, sheet 3 of 4 .....	D-42
MM-5-2 Action Plan, sheet 4 of 4 .....	D-43
MM-5-3 Day Plan, sheet 1 of 2 .....	D-44
MM-5-3 Day Plan, sheet 2 of 2 .....	D-45
MM-5-4 Schedule, sheet 1 of 3 .....	D-46
MM-5-4 Schedule, sheet 2 of 3 .....	D-47
MM-5-4 Schedule, sheet 3 of 3 .....	D-48
MM-5-5 Exception Day Program .....	D-49
<b>Detector Submenu .....</b>	<b>D-50</b>
MM-6-1 Vehicle Detector Assignment, sheet 1 of 2 .....	D-50
MM-6-1 Vehicle Detector Assignment, sheet 2 of 2 .....	D-51
MM-6-2 Vehicle Detector Setup, sheet 1 of 16 .....	D-52
MM-6-2 Vehicle Detector Setup, sheet 2 of 16 .....	D-53
MM-6-2 Vehicle Detector Setup, sheet 3 of 16 .....	D-54
MM-6-2 Vehicle Detector Setup, sheet 4 of 16 .....	D-55

- MM-6-2 Vehicle Detector Setup, sheet 5 of 16 ..... D-56
- MM-6-2 Vehicle Detector Setup, sheet 6 of 16 ..... D-57
- MM-6-2 Vehicle Detector Setup, sheet 7 of 16 ..... D-58
- MM-6-2 Vehicle Detector Setup, sheet 8 of 16 ..... D-59
- MM-6-2 Vehicle Detector Setup, sheet 9 of 16 ..... D-60
- MM-6-2 Vehicle Detector Setup, sheet 10 of 16 ..... D-61
- MM-6-2 Vehicle Detector Setup, sheet 11 of 16 ..... D-62
- MM-6-2 Vehicle Detector Setup, sheet 12 of 16 ..... D-63
- MM-6-2 Vehicle Detector Setup, sheet 13 of 16 ..... D-64
- MM-6-2 Vehicle Detector Setup, sheet 14 of 16 ..... D-65
- MM-6-2 Vehicle Detector Setup, sheet 15 of 16 ..... D-66
- MM-6-2 Vehicle Detector Setup, sheet 16 of 16 ..... D-67
- MM-6-3 Ped Detector Phase Assignment ..... D-68
- MM-6-4 Log Intervals – Speed Detector Setup ..... D-68
- MM-6-5 Vehicle Detector Diagnostics, sheet 1 of 4 ..... D-69
- MM-6-5 Vehicle Detector Diagnostics, sheet 2 of 4 ..... D-70
- MM-6-5 Vehicle Detector Diagnostics, sheet 3 of 4 ..... D-71
- MM-6-5 Vehicle Detector Diagnostics, sheet 4 of 4 ..... D-72
- MM-6-6 Ped Detector Diagnostics ..... D-73
  
- Appendix E - Event Log Messages ..... E-1**
- Appendix F - ASC/3 Hardware Diagnostic Screens ..... F-1**
  - Diagnostic Screen Examples ..... F-2**
  
- Appendix G - Part Number and Software File Management ..... G-1**
  - ASC/3, ASC/3-2070 and ASC/3-LX Part Numbers ..... G-1**
  - Database Sets ..... G-3**
    - ASC/3 and ASC/3-2070 Database Set ..... G-3
    - ASC/3-LX Database Set ..... G-4
  - Creating and Restoring Default Database ..... G-5**
  - Database Creation and Modification ..... G-6**
    - Supporting Software ..... G-6
  
- Appendix H - Coordination Pattern ..... H-1**
- Appendix I - ASC/3 Boot Menu Tree ..... I-1**
- Appendix J - Interface Connector Pin Lists ..... J-1**
  - Default Mapping for ASC/3 and ASC/3-2070 ..... J-1**
  - Default Mapping for ASC/3-LX ..... J-2**

I/O Mode Bits (3 per unit) .....	J-4
Connector D .....	J-7
Port 3B 25-pin Telemetry Connector .....	J-9
CU Port 1 SDLC .....	J-10
Type 1 Power .....	J-11
Port 2/C50S Terminal .....	J-11
Port 3A EIA-232 Telemetry .....	J-12
Port 3B 9-pin FSK Telemetry Connector .....	J-12
<b>Appendix K - BIU Connector Pin Lists .....</b>	<b>K-1</b>
<b>Appendix L - Logic Processor Operation .....</b>	<b>L-1</b>
<b>Introduction .....</b>	<b>L-1</b>
<b>General LP Programming Operation .....</b>	<b>L-2</b>
IF Condition – Testable Elements .....	L-2
THEN/ELSE – Executable Elements .....	L-5
Logic Flags .....	L-7
<b>Testable Elements in the IF Condition .....</b>	<b>L-9</b>
Phase Testable Elements .....	L-9
Ring Timer Testable Elements .....	L-10
Ring Input Testable Elements .....	L-12
Overlap Testable Elements .....	L-13
Coordinator Testable Elements .....	L-14
Preemptor Testable Elements .....	L-15
Detector Testable Elements .....	L-17
Time-of-Day (TOD) Testable Elements .....	L-18
Logic Processor (LP) Testable Elements .....	L-19
CIB & COB Testable Elements .....	L-19
Miscellaneous Testable Elements .....	L-19
<b>Executable Elements in THEN/ELSE .....</b>	<b>L-20</b>
Phase Output Executable Elements .....	L-20
Overlap Output Executable Elements .....	L-20
Detector Input Executable Elements .....	L-21
Ring Input Executable Elements .....	L-21
Unit Input Executable Elements .....	L-22
Phase Input Executable Elements .....	L-24
Logic Processor (LP) Executable Elements .....	L-25

Miscellaneous Executable Elements .....	L-25
<b>Appendix M - Hardware Diagnostic Cables .....</b>	<b>M-1</b>
General Information .....	M-1
33279G1 – ASC-2100 A Connector Loop Back Cable .....	M-2
33279G2 – ASC-2100 B Connector Loop Back Cable .....	M-3
33279G3 – ASC-2100 C Connector Loop Back Cable .....	M-4
33279G4 – ASC-2100 D Connector Loop Back Cable .....	M-5
33279G5 – 25-Pin FSK Loop Back Diagnostic Cable .....	M-6
33279G6 – 9-Pin FSK Loop Back Cable .....	M-7
33279G7 – 15-Pin SDLC Loop Back Cable .....	M-7
33279G8 – 25-Pin Port 2 Loop Back Cable .....	M-7
100-1044-501 – 20-Pin Telemetry Interface Loopback Connector .....	M-7
33279G10 – 9-Pin Port 3A Test Cable .....	M-8
Ethernet Crossover Cable .....	M-8
32864G1 – ASC-2S/1000 Power Cable .....	M-8
<b>Appendix N - Pretimed Controller Operation .....</b>	<b>N-1</b>
General Information .....	N-1
Pretimed Operation .....	N-1
Pretimed Operation During Coordinated Operation .....	N-2
<b>Appendix O - Boot Mode Hyperterminal Transfer .....</b>	<b>O-1</b>
<b>Appendix P - ASC/3-2070 Software Utility .....</b>	<b>P-1</b>
<b>Appendix Q - Diamond Intersection Application Notes .....</b>	<b>Q-1</b>
Diamond Intersection .....	Q-1
Default Database Programming .....	Q-2
Diamond Menus and Configurations .....	Q-3
Diamond Sequence & Phase Ring Assignment, MM-1-1-5-1 .....	Q-3
Diamond Phase Compatibility, MM-1-1-5-2 .....	Q-4
Diamond Backup Prevent, MM-1-1-5-3 .....	Q-5
Default Overlaps .....	Q-6
Default Channel Assignments .....	Q-6
Selection of Diamond Phasing .....	Q-7



Switching Sequences/Phasing .....	Q-8
Phase Timing and Detector Programming .....	Q-9
<b>Four-Phase Diamond .....</b>	<b>Q-10</b>
Four-Phase Diamond Mode .....	Q-10
Sequence and Concurrency Programming .....	Q-10
Four-Phase Diamond Detector Programming .....	Q-12
Coordination .....	Q-13
<b>Three-Phase Diamond .....</b>	<b>Q-14</b>
Three-Phase Diamond Mode .....	Q-14
Sequence and Concurrency Programming .....	Q-14
Three-Phase Diamond Detector Programming .....	Q-16
Coordination .....	Q-17
<b>Separate Intersections .....</b>	<b>Q-18</b>
Separate Intersection Mode .....	Q-18
Sequence and Concurrency Programming .....	Q-18
Separate Intersection Diamond Detector Programming .....	Q-20
Coordination .....	Q-21
<b>NEMA .....</b>	<b>Q-22</b>
Sequence and Concurrency Programming .....	Q-22
<b>ASC/3 Changes .....</b>	<b>Q-24</b>
Controller Start/Flash, MM-2-5, PWR START SEQ .....	Q-24
Coordinator Active Pattern, MM-3-2, SEQUENCE .....	Q-24
Time Base Active Step, See MM-5-4, CONTROLLER SEQ .....	Q-24
Commanded and Runtime Sequences .....	Q-24
<b>Controller Programming Status .....</b>	<b>Q-25</b>
Pre-Programmed Database Selection Menus .....	Q-25
Phase Ring Sequence and Assignment Screen, MM-1-1-5-1 .....	Q-26
Phase Compatibility Screen, MM-1-1-5-2 .....	Q-27
Backup Prevent Phases Screen, MM-1-1-5-3 .....	Q-28
<b>NEMA Sequence Charts for Four-Phase Diamond .....</b>	<b>Q-29</b>
Sequences Starting From Phases 2 and 5 .....	Q-29
Sequences Starting From Phases 3 and 5 .....	Q-30
Sequences Starting From Phases 4 and 5 .....	Q-31
Sequences Starting From Phases 1 and 6 .....	Q-32
Sequences Starting From Phases 1 and 7 .....	Q-33
Sequences Starting From Phases 1 and 8 .....	Q-34
<b>Appendix R - Warning Checks .....</b>	<b>R-1</b>

- Configuration Checks ..... R-2
- Controller Checks ..... R-4
- Coordinator Checks ..... R-9
- Preemptor/TSP Checks ..... R-10
- Time Base Checks ..... R-13
- Detector Checks ..... R-14
  
- Appendix S - CIB/COB Tables ..... S-1**
  - Controller Input Buffer (CIB) ..... S-1**
  - Controller Output Buffer (COB) ..... S-8**
  
- Appendix T - Glossary ..... T-1**
  - Introduction ..... T-1
  - Acronyms ..... T-1
  - Controller Terms ..... T-2
  - Abbreviations in Connector Pin Functions ..... T-14

---

# Introduction

## Purpose of this Manual

This programming manual gives procedures for the Econolite Advanced System Controllers, Series 3 (*ASC/3*). It is written for qualified programmers and operators of traffic controllers. Use this manual to program and operate the traffic signal controllers given below:

- The Econolite *ASC/3*

**Or**

- The Econolite Advanced Transportation Controller (ATC) Model 2070 Controller Unit with *ASC/3-2070* software

**Or**

- The Econolite Advanced Transportation Controller (ATC) Model 2070 Controller Unit with a 2070-1C CPU module and *ASC/3-LX* software

---

**Note** • ATC acronyms used in this document have two different meanings:

- The “ATC” in “ATC 2070 Controller” is part of the name of a controller that conforms to a Caltrans standard.
- The “ATC” associated with *ASC/3-LX* software refers to software that runs on an engine board that was designed to *ATC Standard v06.0x*. The 2070-1C CPU is a host module with an ATC-standard engine board mounted on top.

---

The instructions in this programming manual tell you how to enter software control parameters into an *ASC/3* or *2070* with *ASC/3-2070* or *ASC/3-LX* software. The purpose is to correctly configure the controller for both vehicular and pedestrian traffic patterns in the pre-defined traffic area.

---

**Note** • The *ASC/3-LX* software is a Linux version of the *ASC/3* software designed to operate on an Econolite 2070-1C CPU module. Linux is an operating system patterned after Unix and is a free and open source software.

---

Use these instructions to do initial system configuration and later to do updates, as necessary. You may need to change the controller parameters for changes in both vehicular and pedestrian traffic patterns, direction of traffic flows, and time-of-day traffic variations.

- Contents of this Manual

## Contents of this Manual

This manual is divided into 14 chapters, followed by the appendices. Where there are differences between the *ASC/3* and the *ASC/3-2070* or *ASC/3-LX*, there are individual sections for each type of software. However, most of the information is the same.

### Chapters

Description	Contents
Chapter 1, <i>Introduction</i>	Describes the purpose and content of this document.
Chapter 2, <i>Installation Procedures</i>	This has two sections, one for the <i>ASC/3</i> series and one for the <i>2070</i> series of controllers.  Gives instructions and precautions for when you unpack, install, and store the controller hardware. This chapter has two tables: Cable Connector Part Numbers and Equipment Environmental Specifications.
Chapter 3, <i>Equipment Descriptions</i>	This has two sections, one for each type of controller. It describes the physical and functional features of each of the possible models of the controllers included in this manual. It also lists the general Operational Features in the system Main Menu.
Chapter 4, <i>Keypads and Displays for ASC/3 and 2070</i>	This describes the basic features and functions of the front panel keypads and displays for both an <i>ASC/3</i> and a <i>2070</i> with <i>ASC/3-2070</i> or <i>ASC/3-LX</i> Software.
Chapter 5, <i>MAIN MENU and Screen Navigation</i>	This starts with a summary of the data and/or status selections on the Main Menu (MM) screen. Then it tells you how to navigate <ul style="list-style-type: none"> <li>■ To the Main Menu</li> <li>■ To a Submenu</li> <li>■ In a screen(s)</li> </ul>
Chapter 6, <i>Configuration, MM-1</i>	<ol style="list-style-type: none"> <li>1 Controller Sequence</li> <li>2 Phase in Use/Exclusive Pedestrian</li> <li>3 Load Switch Assignment</li> <li>4 Port 1 (SDLC)</li> <li>5 Communication Ports</li> <li>6 Enable Logging</li> <li>7 Display/Access</li> <li>8 Logic Processor</li> </ol>

Description	Contents
Chapter 7, <i>Controller</i> , MM-2	<ol style="list-style-type: none"> <li>1 Timing Plans</li> <li>2 Vehicle Overlaps</li> <li>3 Vehicle/Pedestrian Overlaps</li> <li>4 Guaranteed Minimum Time</li> <li>5 Start/Flash Data</li> <li>6 Option Data</li> <li>7 Pre-Timed Mode</li> <li>8 Phase Recall</li> </ol>
Chapter 8, <i>Coordinator</i> , MM-3	<ol style="list-style-type: none"> <li>1 Coordinator Options</li> <li>2 Coordinator Patterns</li> <li>3 Split Patterns</li> <li>4 Auto Permissive Minimum Green</li> <li>5 Split Demand</li> </ol>
Chapter 9, <i>Preempt/TSP/SCP</i> , MM-4	<p><b>Note</b> • <b>TSP = Transit Signal Priority and SCP = Signal Control and Prioritization</b></p> <ol style="list-style-type: none"> <li>1 Preempt Plan 1-10</li> <li>2 Enable Preempt Filtering &amp; TSP/SCP</li> <li>3 TSP/SCP Plan 1-6</li> <li>4 TSP/SCP Split Pattern</li> </ol>
Chapter 10, <i>Time Base</i> . MM-5	<ol style="list-style-type: none"> <li>1 Clock/Calendar Data</li> <li>2 Action Plan</li> <li>3 Day Plan/Event</li> <li>4 Schedule Number</li> <li>5 Exception Days</li> </ol>

- Chapters

Description	Contents
Chapter 11, <i>Detectors</i> , MM-6	<ol style="list-style-type: none"> <li><b>1</b> Vehicle Detector Phase Assignment</li> <li><b>2</b> Vehicle Detector Setup</li> <li><b>3</b> Pedestrian Detector Input Assignment</li> <li><b>4</b> Log Intervals/Speed Detector Setup</li> <li><b>5</b> Vehicle Detector Diagnostics</li> <li><b>6</b> Pedestrian Detector Diagnostics</li> </ol>
Chapter 12, <i>Status Displays</i> , MM-7	<ol style="list-style-type: none"> <li><b>1</b> Controller</li> <li><b>2</b> Coordinator</li> <li><b>3</b> Preemption/TSP/SCP</li> <li><b>4</b> TBC/Action Plan</li> <li><b>5</b> Communications</li> <li><b>6</b> Detectors</li> <li><b>7</b> Flash/SDLC/MMU</li> <li><b>8</b> Inputs/Outputs</li> </ol>
Chapter 13, <i>Utilities</i> , MM-8	<ol style="list-style-type: none"> <li><b>1</b> Copy</li> <li><b>2</b> Reserved</li> <li><b>3</b> Print</li> <li><b>4</b> Transfer</li> <li><b>5</b> Sign On</li> <li><b>6</b> Log Buffers</li> <li><b>7</b> Software Modules</li> </ol>
Chapter 14, <i>Diagnostics Information</i> , MM-9	Information about the location of diagnostic operations data

## Appendices

Description	Contents
Appendix A, <i>ASC/3, ASC/3-2070 &amp; ASC/3-LX Menu Tree</i>	This menu tree shows the hierarchy of all the <i>ASC/3</i> screens, starting at the Main Menu. It shows what keys to press to access each screen.
Appendix B, <i>ASC/3 Screens</i>	Illustrations of all the screens in the <i>ASC/3</i> and <i>2070</i> with <i>ASC/3-2070</i> or <i>ASC/3-LX</i> software
Appendix C, <i>Reserved</i>	
Appendix D, <i>Program Reference Card</i>	A blank copy of the <i>ASC/3</i> Program Reference Card. Use this to establish the programming criteria for your specific controller operating parameters.
Appendix E, <i>Event Log Messages</i>	A list of error messages and flash status condition messages
Appendix F, <i>ASC/3 Hardware Diagnostic Screens</i>	Illustrations of all screens that are used with the Hardware Diagnostics programs
Appendix G, <i>Part Number and Software File Management</i>	
Appendix H, <i>Coordination Pattern</i>	A table that defines the Coordination pattern selected when the interconnect format is TS2 or STD (COS)
Appendix I, <i>ASC/3 Boot Menu Tree</i>	A tree diagram that shows the <i>ASC/3</i> Boot Menu tree
Appendix J, <i>Interface Connector Pin Lists</i>	A pin list for each interface connector
Appendix K, <i>BIU Connector Pin Lists</i>	Pin lists and function assignments for the Terminal & Facilities and the Detector Rack Bus Interface Units (BIUs)
Appendix L, <i>Logic Processor Operation</i>	A list of all the testable elements available to the IF Condition and executable elements available to the THEN and the ELSE Elements — used when you configure logic gates
Appendix M, <i>Hardware Diagnostic Cables</i>	Interconnection information for the set of Loop Back Cables — used when you do Diagnostic tests on the controller
Appendix N, <i>Pretimed Controller Operation</i>	Pre-timed controller operation information
Appendix O, <i>Boot Mode Hyperterminal Transfer</i>	Reserved for future use

## Introduction

---

- *Appendices*

Description	Contents
Appendix P, <i>ASC/3-2070 Software Utility</i>	Reserved for future use
Appendix Q, <i>Diamond Intersection Application Notes</i>	
Appendix R, <i>Warning Checks</i>	
Appendix S, <i>CIB/COB Tables</i>	CIB = Controller Input Buffer COB = Controller Output Buffer
Appendix T, <i>Glossary</i>	



---

# Installation Procedures

## Introduction

### *ASC/3 Installation Instructions*

If you have an *ASC/3* controller, use these installation instructions, given in the paragraphs below:

*Unpacking* on page 2-1

*ASC/3 Installation* on page 2-2

*ASC/3 Preparation* on page 2-2

*ASC/3 Cable Connectors and Part Numbers* on page 2-4

*ASC/3 Environmental Operation Specifications* on page 2-4

*ASC/3 Software Installation* on page 2-5

*ASC/3 Storage/Shipping* on page 2-5

### *2070 Installation Instructions*

If you have a *2070* controller with *ASC/3-2070* or *ASC/3-LX* software, use these installation instructions, given in the paragraphs below:

*Unpacking* on page 2-1

*2070 Installation* on page 2-6

*2070 Hardware Requirements* on page 2-6

*ASC/3-2070 or ASC/3-LX Software Installation* on page 2-6

### **Unpacking**

Your *ASC/3* or *2070* controller is packed in a specially-designed protective shipping carton. All necessary precautions have been taken to make sure that equipment arrives intact and in proper working order. However, to make sure that there is no shipping damage, use the procedure below when you unpack the controller.

### ▪ *ASC/3 Installation*

#### **To unpack the controller:**

- 1** Before you open the shipping container, carefully inspect it for damage. If the container is damaged, unpack the controller unit in the presence of the carrier.
- 2** Save the packing materials because they have been specially designed to protect the controller during shipment. If it is necessary to ship the controller again, you must use the special packing materials.
- 3** Carefully inspect the controller for damage.
- 4** Examine for broken wires, broken connectors, loose components, bent panels, and dents or scratches on the enclosure.
- 5** If you find any physical damage, tell the carrier.

## **ASC/3 Installation**

### *ASC/3 Preparation*

Install *ASC/3-1000*, *ASC/3-2100*, and *ASC/3-RM* controllers in a location where the front panel is easily accessible. Leave adequate room around the controllers so they will be easy to remove. Take care to make sure vents on the backside of the shelf-mount controllers are *not* blocked. For all controllers, **before you apply AC power**, obey the procedures that follow:

#### **For the controller:**

- 1** Loosen the two thumb screws at the top of the panel, and open the front panel.
- 2** Make sure that all modules are secured correctly and all connectors are in place.
- 3** Examine the unit to make sure that all *ASC/3* socket-mounted components are correctly seated.

#### **On the Processor/Power Supply Board:**

- 1** Find the battery jumper JP-2 next to connector J11. During shipping or storage, this jumper is normally placed in the OFF (center-to-right, 2-3) position.
- 2** To activate the backup battery, move jumper JP-2 to the ON (center-to-left, 1-2) position.

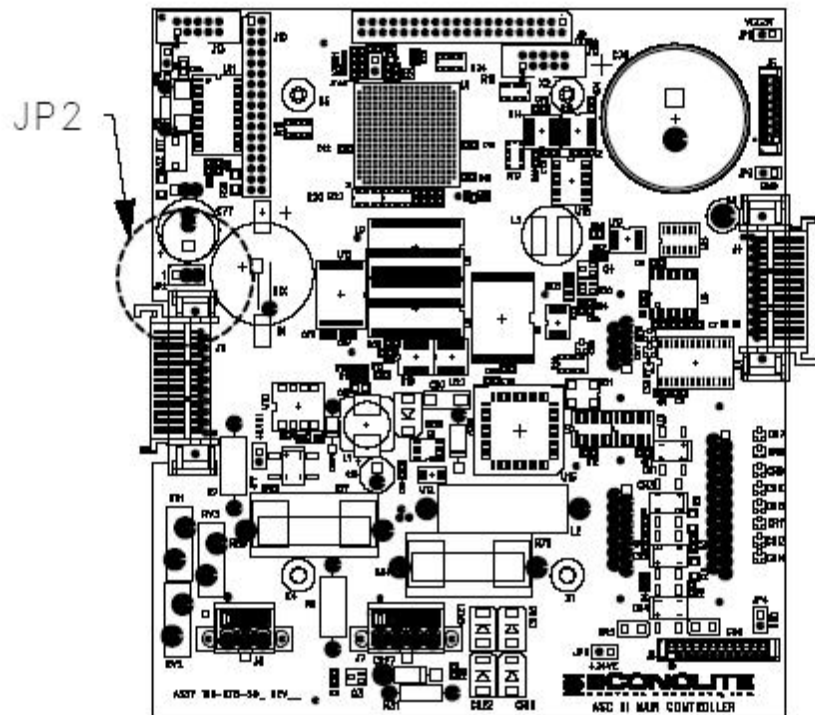
**Processor/Power Supply Board (top left on the front panel)**

---

**IMPORTANT** • If the intersection cabinet is equipped with an MMU or CMU that latches Fault Monitor (FM) or Controller Voltage Monitor (CVM), you *must* set the monitor power-on flash time on the MMU/CMU to nine seconds or more. For setting instructions, refer to the MMU/CMU manufacturer manual.

---

The controller is now ready for installation. Cable connector part numbers are shown below. For pin lists for all interface connectors, refer to Appendix J, *Interface Connector Pin Lists* and Appendix K, *BIU Connector Pin Lists*.

- *ASC/3 Cable Connectors and Part Numbers*

### ASC/3 Cable Connectors and Part Numbers

Connector		Cable Connector	Econolite Part No.
A ( <i>ASC/3-1000</i> ) and Rear Connector ( <i>ASC/3-RM 1000</i> , TS2-T1 only)		MS-3106-18-1S	44181P1
A ( <i>ASC/3-2100</i> )		MS-3116-22-55S	44143P1
B ( <i>ASC/3-2100</i> )		MS-3116-22-55P	44143P2
C ( <i>ASC/3-2100</i> )		MS-3116-24-61P	44143P3
D ( <i>ASC/3-2100</i> )		AMP #205842-1	31163P2
SDLC (Port 1)		CANNON DAU-15P	54665P4
TERMINAL (Port 2)		CANNON DBU-25P	54665P7
TELEMETRY (Port 3A)		CANNON DEU-9S	54647P9
TELEMETRY (Port 3B) (Optional 9-pin)		CANNON DEU-9S	54647P9
(Optional 25-pin)		CANNON DBU-25S	54647P6
Rear Connectors, <i>ASC/3-RM (C1)</i>	C11	AMP #206305-1	31163P29
	C1	AMP #201692-3 (connector)	37134P2
		AMP #202119-2 (shell)	37134P12

### ASC/3 Environmental Operation Specifications

The *ASC/3* controller meets or exceeds the NEMA environmental standards for traffic control equipment, summarized below.

#### **NEMA TS 2-2003 SECTION 2:**

Category	NEMA Environmental Requirement
Ambient Temperature	Operating Range: -34°C to +74°C Storage Range: -45°C to +85°C
Humidity	Relative humidity is not to exceed 95% over the temperature range of +4.4°C to +43.3°C

Category	NEMA Environmental Requirement
Vibration	The controller will maintain its programmed functions and physical integrity when subjected to a vibration of up to 0.5g at 5 to 30 cycles per second, applied in each of the three mutually perpendicular planes.
Shock	The controller will not suffer either permanent mechanical deformation or any damage that renders the unit inoperable, when subjected to a shock of 10g applied in each of the three mutually perpendicular planes.

### *ASC/3 OS Support*

There are 2 versions of *ASC/3* OS depending on the supplied AC power type. With 60 Hz power, OS version 1.xx.xx is required. With 50 Hz power, OS version 2.xx.xx is required.

### *ASC/3 Software Installation*

To install software, refer to *ASC/3 Utility* instruction that comes with the Controller Software release package.

### *ASC/3 Storage/Shipping*

If it is necessary to store or ship an *ASC/3* controller that is equipped with a backup battery, move the battery jumper JP-2 to the OFF (center-to-right, 2-3) position.

- 2070 Installation

## 2070 Installation

You install software and maintain the system through a serial port on the PC or laptop and the front panel port, C50S, and Ethernet port on the 2070 controller.

### 2070 Hardware Requirements

**The hardware requirements are:**

- A computer that has a serial port.
- A serial download cable (either part # 35119G20, 21 or 22, depending on the length needed). The wiring configuration is illustrated below:

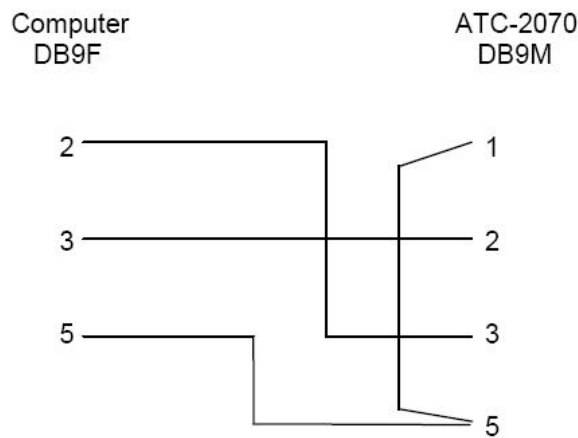

- Cross-over Ethernet cable, or regular Ethernet cable going through a network switch.

### ASC/3-2070 or ASC/3-LX Software Installation

To install software, refer to the *ASC/3-2070* or *ASC/3-LX Utility* instruction that comes with every Controller Software release package.

## Supporting Windows Applications

Below are listed several Windows applications that are included in the *ASC/3* software package to help you manage the controller software. For more information, refer to the respective manual — also in the software package.

Name	Functions
<i>ASC/3</i> Utility	Only for <i>ASC/3</i> & <i>ASC/3-RM</i> (RackMount) controllers <ul style="list-style-type: none"> <li>■ Download application, OS, and database to the controller.</li> <li>■ Upload logs and database to the controller.</li> </ul>
<i>ASC/3-2070</i> Utility	Only for 2070 controllers with <i>ASC/3-2070</i> software <ul style="list-style-type: none"> <li>■ Download application, OS, and database to the controller.</li> <li>■ Upload logs and database to the controller.</li> </ul>
<i>ASC/3-LX</i> Utility	Only for <i>ASC/3-LX</i> software <ul style="list-style-type: none"> <li>■ Download application, OS, and database to the controller.</li> <li>■ Upload logs and database to the controller.</li> </ul>
<i>ASC/3</i> Configurator	I/O: mapping, copying, and comparison Timing parameters: programming, copying, and comparison
<i>ASC/3-LX</i> Configurator	Only for <i>ASC/3-LX</i> software Timing parameters: programming, copying, and comparison
<i>ASC/3</i> Security File Manager*	Program front panel access security for up to 50 users.

\* For information about the *ASC/3* Security File Manager, refer to *Front Panel Access Security* on page 4-13 and *Security Access, MM-1-7-3* on page 6-55.

---

**For your notes:**



---

# Equipment Descriptions

## Introduction

If you have an *ASC/3* controller, refer to these equipment descriptions:

*ASC/3 Controllers, General Features* on page 3-2

*Equipment Enclosure Features* on page 3-3

*Central Processing Unit (CPU)* on page 3-3

*Power Supply* on page 3-3

*ASC/3 System Operating Characteristics* on page 3-4

*ASC/3 Inputs/Outputs* on page 3-4

*ASC/3-1000 and ASC/3-RM 1000 (TS2-T1 only) Connector* on page 3-5

*ASC/3-2100 Connectors* on page 3-5

*ASC/3-RM (C1) Connectors* on page 3-5

If you have an *2070* controller, refer to these equipment descriptions:

*The 2070 Family* on page 3-5

*2070 Modules* on page 3-8

- *ASC/3 Controllers, General Features*

## ASC/3 Controllers, General Features

The *ASC/3* Controllers include two shelf-mount models, *ASC/3-1000* and *ASC/3-2100*, and two rack-mount models, *ASC/3-RM 1000 (TS2-T1 only)* and *ASC/3-RM (C1)*, shown below. As you can see, all the *ASC/3* Controllers have the same displays and keypads on the front panels. However, the connectors and fuses are different::

- The *ASC/3-1000* has one fuse and one input/output connector.
- The *ASC/3-2100* has two fuses and four input/output connectors.
- The *ASC/3-RM 1000 (TS2-T1 only)* has one fuse with an input/output connector at the rear.
- The *ASC/3-RM (C1)* has one fuse with C1/C11 connectors at the rear.

The *ASC/3* controller designs use the latest microprocessor, display, and keypad technology. Fewer components increase overall system reliability with an efficient use of space. Each controller has two main electronic modules that you can access without extender cards.

There are minor differences in the databases for the *ASC/3-1000*, *ASC/3-2100* and *ASC/3-RM (C1)* because the hardware platforms are different. These differences are clearly indicated in the text describing the data entries.

Only brief descriptions of the physical characteristics are included in this document. Detailed physical specifications and descriptions are included in the respective *ASC/3* maintenance manuals.



**ASC/3-1000, Shelf Mount**



**ASC/3-2100, Shelf Mount**



**ASC/3-RM, RackMount, Front Panel**



**ASC/3-RM (C11), Rear View**



**ASC/3-RM 1000 (TS2-T1 only), Rear View**

## Equipment Enclosure Features

All *ASC/3* controllers are enclosed in an aluminum enclosure, designed for either shelf-mount or rack-mount in a street-side cabinet.

## Central Processing Unit (CPU)

All four *ASC/3* controllers use the Motorola MPC862 Power PC Reduced Instruction Set Computer (RISC) Processor and, as a result, can all run the same software programs and use the same database configuration. For these reasons, use this programming manual for all four *ASC/3* controllers.

## Power Supply

Each *ASC/3* controller has an easily-accessible power supply assembly.

- *ASC/3 System Operating Characteristics*

## ASC/3 System Operating Characteristics

An *ASC/3* functions as a semi-actuated or fully-actuated traffic controller unit in accordance with the National Electrical Manufacturers Association (NEMA) Standards Publication TS2-2003.

An *ASC/3* operates as a 16-phase controller with any combination of 16 vehicle phases, 16 pedestrian phases, 16 timed overlaps, and four timing rings. A configuration file may be specifically programmed to meet customer configuration requirements. In addition to the standard controller capabilities, an *ASC/3* has outstanding software and hardware features that greatly simplify programming, operation, monitoring, and maintenance.

Programming is completely menu-driven and in most cases involves only option selections or numeric value data entries. Control flexibility is provided by numerous programming options and enhancements that include time-base coordination, preemption, and diagnostic capabilities. You can monitor real-time controller activity with the dynamic status displays, which together show all controller dynamic parameters.

## ASC/3 Inputs/Outputs

All four of the *ASC/3* models — the *ASC/3-1000* and *ASC/3-2100*, and the two rack-mount models, *ASC/3-RM 1000* (TS2-T1 only) and *ASC/3-RM (C1) ASC/3* — have the same control functions, but use different hardware input/output (I/O) configurations to interface with other components in a traffic control cabinet.

All *ASC/3* models include three serial communication channels. The Port 1 channel (SDLC) is used to exchange data with a Malfunction Management Unit (MMU), retrieve vehicle detector data from detector rack Bus Interface Units (BIUs) and route I/O functions through Terminal and Facility BIUs. Port 2 and Port 3A are serial communication ports that use an RS-232 interface. An optional Port 3B supplies either a 25-pin or 9-pin System Communication port that uses frequency-shift-keying (FSK), or a 5-pin or 9-pin Serial Communication port; this port is compatible with the *ASC/2* and *ASC-8000* controllers.

### **The Port interfaces for ASC/3 series are:**

- Port 1 NEMA TS2 3.3.1
- Port 2 NEMA TS2 3.3.2
- Port 3A NEMA TS2 3.3.3-specified connector used for RS232 communication
- Port 3B (Optional plug-in module) NEMA TS2 3.3.3-specified connector used for FSK communication

### ASC/3-1000 and ASC/3-RM 1000 (TS2-T1 only) Connector

The single NEMA-specified “A” connector on the front panel of an *ASC/3-1000* controller and the rear panel of an *ASC/3-RM 1000* (TS2-T1 only) meets NEMA TS2 Type 1 requirements, as referenced in NEMA TS2 3.3.4.

### ASC/3-2100 Connectors

The *ASC/3-2100* controller has NEMA specified “A”, “B”, “C” connectors and meets the NEMA TS2 Type 2 requirements, referenced in NEMA TS2 3.3.5. In addition, an Econolite specific “D” connector allows the model 2100 to replace any NEMA TS1, NEMA TS2, ASC-8000 or other controllers (with adapter cables).

### ASC/3-RM (C1) Connectors

The *ASC/3-RM* (C1) rack-mount controller has C1/C11 connectors.

## The 2070 Family

### 2070 L

#### 2070 L Front View



#### 2070 L Rear View

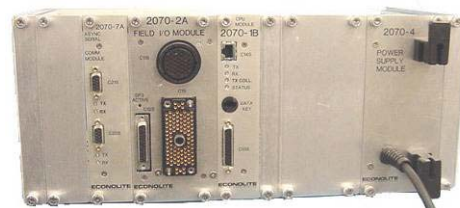

The 2070 L uses the 2070-1B and 2070-2A field I/O modules with a C1 connector. This configuration replaces 170-type controllers, and is compatible with the 170 I/O connectors.

- 2070 LN

## 2070 LN

### 2070 LN Front View



### 2070 LN Rear View

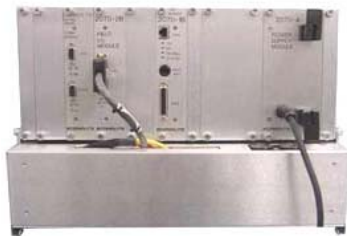

The 2070 LN replaces a TS1 or TS Type 2 controller and contains one 2070-2B module and a 2070-8 NEMA field I/O module.

2070 ITS

**2070 ITS Front View**



**2070 ITS Rear View**



The 2070 ITS replaces an ITS or TS2 Type 1 and has 2070-1B and 2070-2B modules.

- 2070 Modules

## 2070 Modules



With each model, you can install the cards shown in the list below into the serial motherboard through the indicated slots of the card cage.

Type	Module Model No.	Description	Slot				
			A1	A2	A3	A4	A5
CPU	2070-1B	Processor Card running OS/9, TEES 1999, TEES 2002					X
	2070-1E	CPU Lite, running OS/9, TEES 2009					X
	2070-1C	CPU Host Module with ATC Engine Board, running Linux OS					X
I/O	2070-2A	Field I/O Module with C1 and C11 connectors, TEES 2002			X	X	
	2070-2B	Dual SDLC Interface Card for TS1 or TS2 Type 2			X		
	2070-2E	Field I/O Module with C1 and C11 connectors, TEES 2009			X	X	
	2070-2N	Field I/O module for TS2 Type 1			X	X	
Comm	2070-6A	Dual 1200-baud FSK Modem	X	X			
	2070-6B	Dual zero 9600-baud Modem	X	X			
	2070-7A	Has a Dual async Serial Communications Module, with hardware flow control for external modem interfaces	X	X			



## ASC/3 NEMA & 2070 HW Differences

ASC/3 2070 Hardware	ASC/3 Hardware
Serial Port Support: SP1/C21S, SP2/C22S, and SP4/C50S	Port 2, Port 3A, Port 3B, Port1(SDLC)
8-line LCD display – user has to scroll down to see the content of the 16 line display. Next key is recommended to scroll.	16-line LCD display
10BaseT Ethernet	10/100 BaseT Ethernet
External storage: Data key	External storage: Token key
2070 Keyboard is remapped based on ASC/3 keyboard. An keyboard overlay is available in both the manual or can be ordered	Keyboard is native to ASC/3 Controller
<b>NEMA TS1</b> cabinet requires a 2070-8.	ABCD connectors are included in ASC/3-2100
<b>NEMA TS2 Type 1</b> cabinet requires a 2070-2N	SDLC connector is included in ASC/3 Port 1
<b>NEMA TS2 Type 2</b> cabinet requires a 2070-2B and 2070-8	ABCD connectors & SDLC connector are included in ASC/3-2100
<b>300 series</b> cabinets requires a 2070-2A module	<b>300 series</b> cabinets require an ABCD to C1 adaptor.
<b>FSK</b> requires 6B or 6A module. ECIPIP on 6A module with ASC/2M at 1200 bps has not been proven to work.	FSK requires a Telemetry module.

---

**For your notes:**

# Keypads and Displays for ASC/3 and 2070

## Introduction

This chapter describes and gives basic operating procedures for the Function Keypads, Numeric Keypads, and the Liquid Crystal Displays (LCDs) for both the *ASC/3* and *2070* Controllers.

Although the functions of the *ASC/3* and *2070* are almost the same, the Keypads and LCDs have differences, as listed below.

### Keypads

---

**Note** • In this manual, bold face type identifies a key on a keypad. For example, “Press **1**.” = “Press the #**1** key.” At times, to clarify, we insert the word “Key”. For example, “In an alpha data field, Key **2** enters an A.”

---

The functions for an *ASC/3* Controller are written on the keys. However, for a *2070* Controller with *ASC/3-2070* or *ASC/3-LX* software, the keys are different. To know which keys are equivalent to the functions, refer to the table below.

Function	ASC/3 Key	2070 Key
Main Menu	<b>MAIN MENU</b>	<b>A</b>
Sub Menu	<b>SUB MENU</b>	<b>ESC</b>
Toggle Forward	<b>0</b>	<b>YES or 0</b>
Toggle Back	<b>8</b>	<b>NO or 8</b>
Next Data	<b>NEXT DATA</b>	<b>D</b>
Next Screen	<b>NEXT SCREEN</b>	<b>NEXT</b>
Next Page	<b>NEXT PAGE</b>	<b>+</b>
Status Display	<b>STATUS DISPLAY</b>	<b>E</b>
Help	<b>HELP</b>	<b>F</b>
Enter	<b>ENTER</b>	<b>ENT</b>

- *Liquid Crystal Displays (LCDs)*

Function	ASC/3 Key	2070 Key
Special Function	SPEC FUNC	*
Clear	CLEAR	C
When in a hyperlink field, to follow the hyperlink	SPEC FUNC then NEXT DATA	B

For the 2070, an alternative way to know which key to use for each function is to install a keypad overlay on the front panel. Refer to *2070 Keypad Overlay* on page 4-5 for an illustration of a 2070 keypad overlay.

### *Liquid Crystal Displays (LCDs)*

The dimensions of the LCDs of the two types of controllers are given in the table below.

Type of Controller	Dimensions of the LCD
<i>ASC/3</i>	40 characters wide by 16 lines high
<i>2070</i>	40 characters wide by 8 lines high

As much as possible, to prevent scrolling with the 2070, the text of the displays is written to fit in 8 lines.

---

**Note** • Usually, in this manual, the 16-line displays for the ASC/3 are shown. With the 2070 displays, blank lines are deleted to fit the text into the 8-line display.

---

## ASC/3-Specific Functions and Display

### ASC/3 LCD Screen

The User Interface module contains an LCD formatted as 16 lines of 40 characters, the display contrast control, the display backlight circuit, the display heater circuit, the keypad matrix and the system buzzer. The display contains its own control and drive electronics. The User Interface connector, J3, connects the display to the processor module.

### ASC/3 Function and Numeric Keypads

The Function Keypad, shown below, contains a group of keys that provides control of specific functions used within the ASC/3 system. Generally they control selection of displays and navigation in and between display screen pages. Refer to the paragraphs that follow.

**To adjust the backlight contrast:**

- ▶ Press the two small arrow-shaped keys at the left of the cursor/enter array.

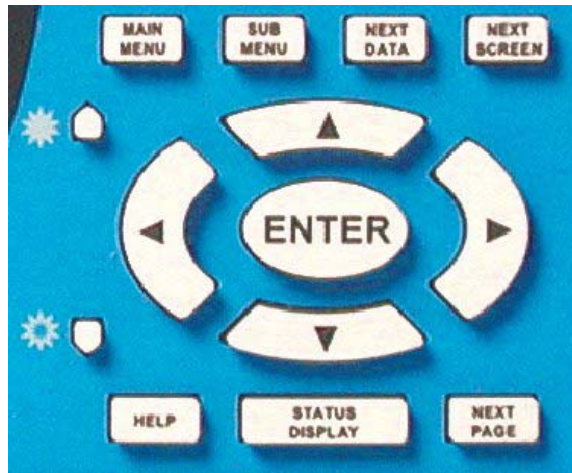

The Numeric Keypad, shown below, contains a group of numbered keys, **0** thru **9**, used to enter numerical information into the system memory. This keypad also has two other keys, **SPEC FUNC** (Special Function) and **CLEAR**. There are also alphabetic characters, special characters, and words printed above the keys to show other functions for which they are used. Refer to the paragraphs that follow.



## 2070-Specific Functions and Display

### 2070 LCD and Key Click

The Liquid Crystal Display (LCD) has 8 lines of 40 characters with a backlight. Use a knob on the front panel to control the contrast of the LCD. There is an optional key click that operates to make a sound when you press a key. You can enable/disable the key click with MM-1-7-2; refer to *ASC/3 & 2070 Key Click and Backlight* on page 4-6.

- *AUX Switch*

## *AUX Switch*

When the AUX switch is ON, it activates CIB bit 424 and you can perform different actions through Logic Processor statements — for example, stop time and interval advance.

## *2070 Keypads*

Use the keypads, shown below, to control the *2070* system. To map the *2070* keypad to that of an *ASC/3* Controller, you can order an overlay to install over the keypads; refer to *2070 Keypad Overlay* on page 4-5. For explanations of the key functions, refer to *ASC/3 & 2070 Key Functions* on page 4-6.

### **2070 Keypads**



### 2070 Keypad Overlay

A keypad overlay labels the functions of the 2070 keys that are used with *ASC/3-2070* and *ASC/3-LX* software. You can order a keypad overlay, as shown below, and install it on the front panel around the key pads.

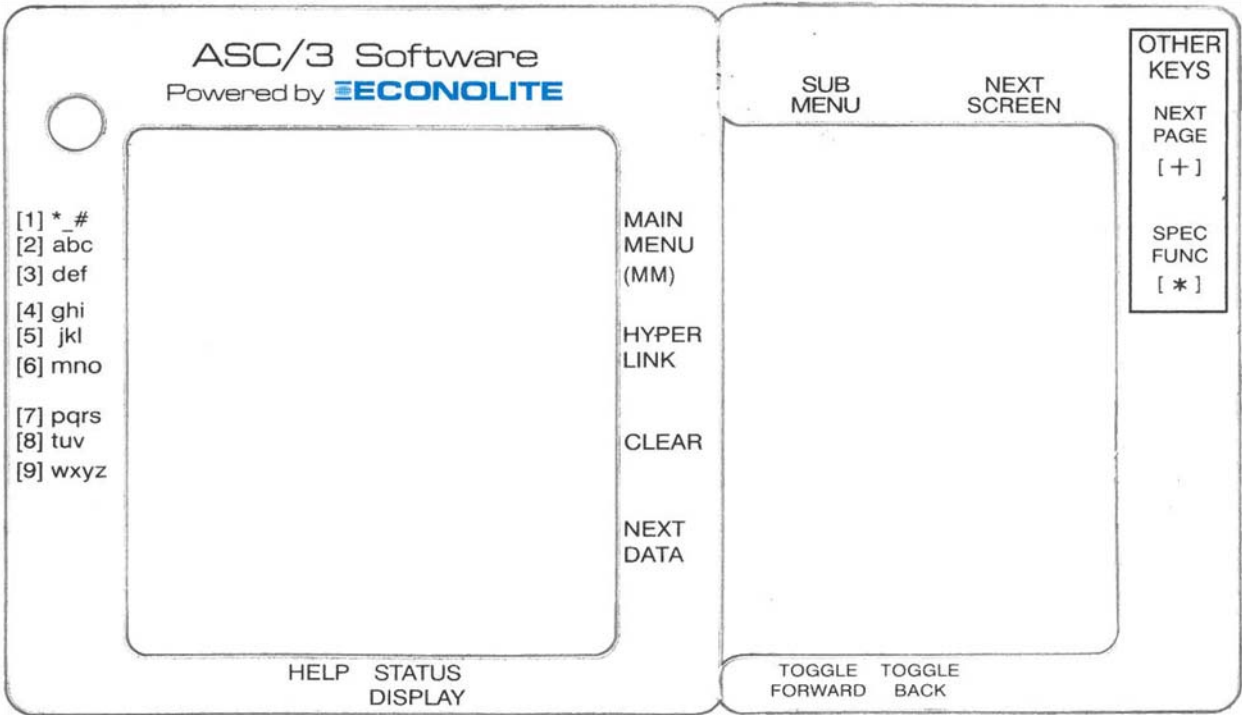

### 2070 Display Contrast Adjust Knob

There is a CONTRAST knob on the right side of the front panel. To adjust the contrast of the LCD, turn this knob.

- *ASC/3 & 2070 Key Click and Backlight*

## ASC/3 & 2070 Key Click and Backlight

Use Display Options, MM-1-7-2, to enable/disable Key Click and Backlight. Press **0** (for 2070, press **YES**), toggle, to enable (YES) or disable (NO) these functions.

- When the Key Click function is enabled, each time you press a key, you hear the sound of a “beep”.
- When the Backlight function is enabled, the LCD backlight comes ON.

### MM-1-7-2

```
DISPLAY OPTIONS
KEY CLICK ENABLE..... YES
BACKLIGHT ENABLE..... YES
LED MODE..... AUTO
MAIN STATUS DISPLAY MODE..... ADVANCED
```

## ASC/3 & 2070 Key Functions

### MAIN MENU *or A*

#### To show the Main Menu (MM):

- 1** Press and release **MAIN MENU** (for 2070, press and release **A**).

The main menu lists nine submenus that contain the different data entry and status displays.

- 2** While the Main Menu is in view, press one of the keys **1** thru **9** that relates to the desired submenu title.

The submenu comes into view.

For example, while viewing the Main Menu screen, press **2** and the Controller Submenu screen comes into view.

### MAIN MENU (MM)

```
MAIN MENU
1. CONFIGURATION      6. DETECTORS
2. CONTROLLER         7. STATUS DISPLAY
3. COORDINATOR       8. UTILITIES
4. PREEMPTOR/TSP     9. DIAGNOSTICS
5. TIME BASE
```



To immediately return to the Main Menu from any other screen, press and release **MAIN MENU** (for 2070, press **A**).

## SUBMENU or ESC

### From any screen, to go rearward to see its submenu screen:

- ▶ Press and release **SUBMENU** (for 2070 press and release **ESC**).
- ▶ If you continue to press this key, you will move back through previous submenu screens until you get to the Main Menu.

## NEXT DATA or D

### To search the controller for non-zero data:

- 1 Press and release **NEXT DATA** (for 2070, press **D**)

A prompt asks for direction.

- 2 Press a cursor (arrow) key to select the direction of the search. There are two possible directions for this function. The up/left arrows (▲, ◀) have the same effect and down/right arrows (▼, ▶) have the same effect.

The controller searches for non-zero data and goes to that screen and lets you search through data screens for valid entries.

## NEXT SCREEN or NEXT

### To move a screen forward through the screens in the selected submenu:

- ▶ Press **NEXT SCREEN** (**NEXT** for 2070)

The arrows at the top right of the screen show the possible direction(s) to access more screens. If there is only one direction (down or right) the controller automatically goes to the next screen.

### If there are two possible directions:

- ▶ When a prompt asks for direction, press an applicable arrow key.
  - The next screen in the selected direction comes into view.
  - When you get to the end of the screens, the display wraps back to the start.

- *NEXT PAGE* or +

## NEXT PAGE or +

When you press this key you can advance a single page or rapidly advance page-by-page to the previous or next group of data entry screens (data group) in a submenu.

### Single Page Advance:

- 1 Press and release **NEXT PAGE** (for 2070 press and release +).

A prompt asks for direction.

- 2 Press the applicable cursor up or down arrow key to go to the next page in that direction.

### Rapid Page Advance:

- 1 Press and hold **NEXT PAGE** (for 2070, press and hold +).

A prompt asks direction.

- 2 While you continue to hold **NEXT PAGE/+**, press the applicable cursor arrow key until you get to the page you want.

- 3 Release the keys.

## STATUS DISPLAY or E

### To go to the main controller Status Display:

- ▶ Press **STATUS DISPLAY** (for 2070, press **E**).

This screen shows a large variety of current status indications for the intersection(s) being serviced by this controller. For detailed information about this screen, refer to *Main Status Displays* on page 12-2.

## HELP or F

### To show help screens:

- 1 Move the cursor to a field.
- 2 Press **HELP** (for 2070, press **F**).

The help screens give information about the data entry field or status display at the cursor location.

### To exit from help:

- ▶ Press **CLEAR** (for 2070, press **C**).

Or

- ▶ Press **HELP/F** again.

## SPEC FUNC then HELP or \* then F

From any screen:

### To see general help information about basic ASC/3 functions:

- ▶ Press **SPEC FUNC** then **HELP** (for 2070, press \* then **F**).

### To exit from this help:

- ▶ Press **CLEAR** (for 2070, press **C**).

**Or**

- ▶ Press **HELP/F** again.

## Cursor Arrow Keys

These four keys move the cursor in the direction of the arrow on the key:

up ▲

down ▼

right ►

left ◀

### To move the cursor a short distance:

- ▶ Press and *release* the arrow key.

### To move the cursor at a moderate speed:

- ▶ Press and hold the arrow key.
- ▶ To stop the cursor, release the key.

## ENTER or ENT

### To store data or to execute a function (as described below):

- ▶ Press **ENTER** (for 2070, press **ENT**).

### After you enter data, to Store Data:

- ▶ Press **ENTER** (for 2070, press **ENT**).

**Or**

- ▶ Exit the data field (press a cursor arrow key or press a function key to go to the Main Menu or a Submenu).

▪ Number Keys 0 thru 9

**To Execute a Function:**

- ▶ To make sure you do not accidentally execute a major function, the controller requires you to press **ENTER** (for 2070, press **ENT**).

For example, in MM-8-6-3, to clear memory, after you press a number key, there is a prompt to press **ENTER/ENT** if you are sure you want to clear the log.

**Number Keys 0 thru 9**

These keys are usually used to enter numeric data into the system programming files. While viewing a data entry screen, use these keys to enter/select menu options, timing values, detectors, program steps, addresses and other data entry values. With the auto-repeat feature, to enter the same number again and again, continuously press a number key.

**Vehicle Calls**

**To make a Vehicle Call:**

- ▶ Go to any status display, MM-7-X, that has the VEH CALL parameter, and obey the applicable procedure, below.

To Make a Vehicle Call on:	Procedure
All Phases	<ol style="list-style-type: none"> <li>1 Move the cursor to the second L of VEH CALL</li> <li>2 Press <b>ENTER</b> (for 2070, press <b>ENT</b>).</li> </ol>
One Phase (range 1 thru 16)	<ol style="list-style-type: none"> <li>1 Move the cursor to the applicable phase, 1 thru 16.</li> <li>2 Press <b>ENTER</b> (for 2070, press <b>ENT</b>).</li> </ol>
One Phase (range 1 thru 10)	<ol style="list-style-type: none"> <li>1 Move the cursor to anywhere in the VEH CALL line.</li> <li>2 Press the applicable number key <b>1</b> thru <b>0</b>.</li> </ol>

**Alpha-Numeric Keys**

When you put the cursor at an alphanumeric data entry field, the numeric keypad automatically enters the alpha mode. For **2** thru **9**, the letters you can enter for each number key are the same as a standard telephone keypad. The characters for Key **1** are given in an example that follows.

**Examples:**

- Key **1** can input **space \$/>#\*;\'"!@&.?=-1**, Key **2** can input **a b c**, and Key **3** can input **d e f**.
  - When the keypad is in the alpha mode, when you press a numeric key, the first character of its character sequence will come into view in the cursor position. For example, Key **2** enters an **A**; if you do not press Key **2** again within 2 seconds, the letter **A** is entered and you can move the cursor to the next position. If you press Key **2** again in less than 2 seconds, the letter **B** comes into view in the cursor position. If you press Key **2** again and again in less than 2 second intervals, you go through the full sequence of **A B C a b c** and **2**. If you press Key **2** again (in less than 2 seconds), you can repeat the sequence.
  - Each of the numeric keys (except for Key **1** and Key **0**) has a similar sequence in which you input its alphabetical characters in sequence as capital letters, then lower-case letters, then the number itself (for Key **3** the sequence is **D E F d e f 3**); you can repeat the sequence.
  - For Key **1**, the sequence is: **space \$/>#\*;\'"!@&.?=-1**
- 0/YES** and **8/NO** are Toggle keys, described in the paragraph that follows.

**Toggle Keys: 0,8 or YES,NO**

- ▶ Use Key **0** (for *2070*, use **YES**) to “toggle” between two or more choices at a data entry field, such as: YES/NO, ON/OFF, enable (X) or disable (.), red/yellow/green, rings 1/2/3/4, etc. The change between its numeric function and Toggle function is automatic, depending upon the cursor position.
- ▶ To toggle in the opposite direction, use Key **8** (for *2070*, use **NO**). This is especially useful when you program Logic Processor statements in MM-1-8-2, for which there is a very long sequence of choices. If you know the choice you want is close to the end of the sequence, to save time, use **8/NO** to toggle in the opposite direction, starting at the end of the sequence. Also use **8/NO** if you first toggle with **0/YES** through a long sequence and accidentally pass the selection you want. If this happens, press **8/NO** as necessary to go back to the selection you passed.

**Special Function, SPEC FUNC or \***

Use **SPEC FUNC** (for *2070*, use **\***), Special Function, to place Pedestrian Calls or Lock Access to controller data.

**Lock Access****To lock access to controller data entry:**

- ▶ For *ASC/3*, press **SPEC FUNC** then **STATUS DISPLAY**
- ▶ For *2070*, press **\*** then **E**.

- Clear or C

The keypad is locked until you enter supervisor or data change access codes. The Lock Access function operates only if you entered access codes before.

## Clear or C

To clear just-typed data or to exit from help screens, as described below, press **CLEAR** (for 2070, press **C**).

### Clear Data

#### To clear a current data entry and restore the previous entry:

- ▶ For *ASC/3*, press **CLEAR**.
- ▶ For 2070, press **C**.

---

**IMPORTANT** • Make sure you use **CLEAR** (for 2070, **C**) before you store/enter the data (with **ENTER/ENT**, the cursor, or the function keys). After you store the data, **CLEAR/C** has no effect.

---

### Exit Help Screens

After you press **HELP** (for 2070, **F**) and view the help screen:

#### To exit from the help screen:

- ▶ For *ASC/3*, press **CLEAR** or press **HELP** again.
- ▶ For 2070, press **C** or press **F** again.

## Arrows for Screen Navigation

When only part of the full screen shows on the LCD, at the top right there is an arrow(s).

For example: ▼ ▶. This message is at the top right of the LCD to show that you must scroll down and to the right to see the full screen.

Possible arrows are: Up ▲, Down ▼, Right ▶, and Left ◀.

In the example above, when you scroll down, the Up arrow comes into view to show that you can now scroll up to return to the original position. Equally, when you scroll right, the Left arrow comes into view. Thus, it is possible to see all four arrows at the same time.

## Call Simulation with the Keypad

User can simulate Vehicle, Pedestrian, Preemptor, or TSP calls from the keypad while in a Status display. For details, refer to *To make a Call on a Display Row*: on page 12-2.

## Help, HELP or F

When the cursor is at a data entry parameter, in a status screen or in a read-only field, to read context-sensitive information, press **HELP** (for 2070, press **F**).

## Exit

To exit a screen, press **SUBMENU**, **MAIN MENU**, or **STATUS DISPLAY** (for 2070, press **ESC**, **A**, or **E**).

## Front Panel Access Security

Front Panel Security access privileges can be created using the Security Manager software or through Front Panel MM-1-7-3. Once security is activated, users are required to enter a security code to get write access. But, if Front Panel access security is not activated, the controller lets all users access all data and menus.

The system administrator can set access privileges in the security system for up to 50 users. Then, using their assigned 5-digit access codes, the administrator or authorized users may access permitted menus to make system configuration changes. The administrator enters separate menu and data masks for each user. These masks define what data that user may view (Read-Only), view and modify (Read/Write), or Diagnostic level where user can perform more advanced diagnostic functions.

When activated, you can also remotely access the security access provisions with remote NTCIP SNMP messages. These remote messages use a “Community Name” imbedded within the message to know who is sending the message and his/her level of permitted access.

After you access the *ASC/3*, to manually lock the controller against any data entry, press **SPEC FUNC** then press **STATUS DISPLAY** (for 2070, press **\*** then press **E**). If access codes are programmed, the controller also automatically locks after no keypad activity for 20 minutes. When the keypad is locked, it stays locked until you enter administrator or user access codes.

For more information on this security access code feature, refer to the programming instructions in *Security Access, MM-1-7-3* on page 6-55.

---

**For your notes:**



---

# MAIN MENU and Screen Navigation

## Introduction

Start at the Main Menu (MM) screen to program or operate *ASC/3*, *ASC/3-2070* or *ASC/3-LX* software. Throughout this manual, “MM” refers to the Main Menu.

### To access the Main Menu screen:

- ▶ For *ASC/3*, press **MAIN MENU**.
- ▶ For *ASC/3-2070* or *ASC/3-LX* software, press **A** on the left keypad of the 2070.

There are 9 selections on the Main Menu, each of which represents a submenu of a major system data group.

### From the Main Menu, to view or enter data:

- ▶ Press the key pad number **1** thru **9** of the related data group.

Start at the Main Menu to navigate to all normally-accessible system data entry and display screens. Chapters 6 thru 14 tell you about each of these major data groups of an *ASC/3* system. The sequence of these chapters (6 thru 14) is the same as the sequence of the selections (1 thru 9) as described in the Programming Summary table in the next section.

## Main Menu

### Programming Summary

The Main Menu has 9 selections, as shown in the illustration below and described in the table that follows.

Submenus are referenced by the navigation path from the Main Menu. For example, “MM-1” refers to the Configuration submenu.

MAIN MENU	
1. CONFIGURATION	6. DETECTORS
2. CONTROLLER	7. STATUS DISPLAY
3. COORDINATOR	8. UTILITIES
4. PREEMPTOR/TSP	9. DIAGNOSTICS
5. TIME BASE	

▪ *Programming Summary*

Main Menu Option	Programming Summary
1. CONFIGURATION	Access a submenu with 8 data groups that cover controller sequencing, phases in use/exclusive pedestrian, load switch assignment, SDLC options, communication ports, event logging, display/access, and logic processor. Refer to Chapter 6, <i>Configuration</i> for instructions.
2. CONTROLLER	Accesses a submenu with 8 data groups that cover timing plans, vehicle and ped overlap, guaranteed minimum time, start flash data, option data, actuated pre-timed mode, and recall data. Refer to Chapter 7, <i>Controller</i> for instructions.
3. COORDINATOR	Accesses a submenu with 5 data groups that cover Coordinator options, pattern data, split pattern data, auto-permissive minimum green, and split demand. Refer to Chapter 8, <i>Coordinator</i> for instructions.
4. PREEMPTOR/TSP/SCP	Accesses a submenu with 4 data groups that cover Preempt Plan 1-10, Enable Preempt Filtering & TSP/SCP, TSP/SCP Plan 1-6, TSP/SCP Split Pattern. Refer to Chapter 9, <i>Preempt/TSP/SCP</i> for instructions.
5. TIME BASE	Accesses a submenu with 5 data groups that cover clock/calendar, action plans, schedule, day plan events, and exception days. Refer to Chapter 10, <i>Time Base</i> for instructions.
6. DETECTORS	Accesses a submenu with 6 data groups that cover vehicle detector phase select and setup, ped and system detector assignments, log interval/speed detection, vehicle/ped detector diagnostics. Refer to Chapter 11, <i>Detectors</i> for instructions.
7. STATUS DISPLAY	Accesses a submenu with 8 data groups that cover all aspects of Status Display for the entire system. Refer to Chapter 12, <i>Status Displays</i> for instructions.
8. UTILITIES	Accesses a submenu with 7 data groups that cover utilities for copy, a “reserved” data group, print, transfer, sign on, log buffers, and software modules. Refer to Chapter 13, <i>Utilities</i> for instructions.
9. DIAGNOSTICS	Accesses an information screen that refers you to Appendix F, <i>ASC/3 Hardware Diagnostic Screens</i> for instructions on loading the diagnostic file and its operation. Refer to Chapter 14, <i>Diagnostics Information</i> for instructions.

## Display Screen Navigation

### Basic Screen Navigation

This manual illustrates the displays, discusses each submenu and data entry display, and gives programming instructions. Note that each display is identified by the keys to press to access it, for example MM-2-6-1.

---

**Note** • For an 2070, press A for MM (to go to the Main Menu).

---

### To go to MM-2-6-1 (Controller Options data entry) from any other screen:

- 1 Press **MAIN MENU** (for 2070, press **A**).

The Main Menu screen, MM, shown in *Programming Summary* on page 5-1, comes into view.

- 2 Press **2** to select the Controller Menu, MM-2, shown below.

#### MM-2

CONTROLLER SUBMENU	
1. TIMING PLANS	5. START/FLASH
2. VEHICLE OVERLAPS	6. OPTION DATA
3. VEH/PED OVERLAPS	7. ACT PRE-TIMED
4. GUAR MIN TIME	8. PHASE RECALL

- 3 Press **6** to select the Option Data Submenu, MM-2-6, shown below.

#### MM-2-6

OPTION DATA SUBMENU
1. CONTROLLER OPTIONS
2. EXTENDED OPTIONS

- 4 Press **1** to select Controller Options, MM-2-6-1, shown below.

Thus, start at the Main Menu to navigate with applicable submenu selections to get to any normally-accessible data entry or display screen in the system.

- Horizontal Display Screen Scrolling

### Horizontal Display Screen Scrolling

Look below at the data entry screen, Controller Options, MM-2-6-1. With an 2070 with ASC/3-2070 or ASC/3-LX software (8-line display), when you first access it, you see the screen shown below, at the left. However, because there is not enough horizontal space on the screen to show all 16 phases, you have to scroll horizontally to view and/or edit the data for phases 9 thru 16.

**MM-2-6-1**

CONTROLLER OPTIONS										▶
PED CLEAR PROTECT .	UNIT RED REVERT	2.0								
PHASE	1	2	3	4	5	6	7	8		
FLASHING GRN PH	.	.	.	.	.	.	.	.	.	
GUAR PASSAGE....	.	.	.	.	.	.	.	.	.	
NON-ACT I.....	.	X	.	.	.	X	.	.	.	
NON-ACT II.....	.	.	.	X	.	.	.	X	.	

**MM-2-6-1 (Scroll right)**

CONTROLLER OPTIONS																◀
PED CLEAR PROTECT .	UNIT RED REVERT	2.0														
PHASE	9	10	11	12	13	14	15	16								
FLASHING GRN PH	.	.	.	.	.	.	.	.	.							
GUAR PASSAGE....	.	.	.	.	.	.	.	.	.							
NON-ACT I.....	.	.	.	.	.	.	.	.	.							
NON-ACT II.....	.	.	.	.	.	.	.	.	.							

In the upper right corner of the screen, are arrows (▼ and/or ▶) that indicate to scroll vertically down and/or horizontally right to access more data field. For an ASC/3 controller, there is only the right arrow.

**To scroll to the right:**

- ▶ On the Function keypad, repeatedly press ▶.

As you scroll to the right, notice that both right and left arrows are visible (◀ ▶). Notice also that only the Phase columns are scrolled. The top three lines, the data line labels, and the bottom instruction line do *not* scroll. When Phase 16 comes into view (shown above, at the right), only the left arrow (◀) shows to indicate that you cannot go further right.

**To return to the original Phase 1 thru 8 display:**

- ▶ Repeatedly press ◀.

---

**Note** • To jump immediately to the right half of the screen, with ASC/3, press NEXT SCREEN. For a 2070, press NEXT and then the right cursor arrow.

---

### Vertical Display Screen Scrolling

In an 2070, to access the other Controller Options in MM-2-6-1...

**To scroll vertically down:**

- ▶ Repeatedly press ▼.

**To jump a screen at a time:**

- ▶ Press NEXT.

The full MM-2-6-1 screen is shown below.

**MM-2-6-1 (Scroll right/down to access)**

CONTROLLER OPTIONS																
PED CLEAR PROTECT . UNIT RED REVERT																2.0
PHASE	1	2	3	4	5	6	7	8	9	10	11	12	13	14	15	16
FLASHING GRN PH	.	.	.	.	.	.	.	.	.	.	.	.	.	.	.	.
GUAR PASSAGE....	.	.	.	.	.	.	.	.	.	.	.	.	.	.	.	.
NON-ACT I.....	.	X	.	.	.	X	.	.	.	.	.	.	.	.	.	.
NON-ACT II.....	.	.	.	X	.	.	.	X	.	.	.	.	.	.	.	.
DUAL ENTRY.....	.	.	.	.	.	.	.	.	.	.	.	.	.	.	.	.
COND SERVICE....	.	.	.	.	.	.	.	.	.	.	.	.	.	.	.	.
COND RESERVICE..	.	.	.	.	.	.	.	.	.	.	.	.	.	.	.	.
PED RESERVICE...	.	.	.	.	.	.	.	.	.	.	.	.	.	.	.	.
REST IN WALK....	.	.	.	.	.	.	.	.	.	.	.	.	.	.	.	.
FLASHING WALK...	.	.	.	.	.	.	.	.	.	.	.	.	.	.	.	.
PED CLR>YELLOW..	.	.	.	.	.	.	.	.	.	.	.	.	.	.	.	.
PED CLR>RED.....	.	.	.	.	.	.	.	.	.	.	.	.	.	.	.	.
IGRN + VEH EXT..	.	.	.	.	.	.	.	.	.	.	.	.	.	.	.	.

**In general, to vertically scroll up/down a screen:**

- ▶ Press ▲ and ▼.

Illustrated below are the first display of MM-1-1-2 with a 2070 (8-line display), and the full MM-1-1-2 screen.

**MM-1-1-2**

PHASE COMPATIBILITY																v
	6	5	4	3	2	1	0	9	8	7	6	5	4	3	2	
1	.	.	.	.	.	.	.	.	.	.	.	.	.	.	.	
2	.	.	.	.	.	.	.	.	.	.	.	.	.	.	.	
3	.	.	.	.	.	.	.	.	.	.	.	.	.	.	.	
4	.	.	.	.	.	.	.	.	.	.	.	.	.	.	.	
5	.	.	.	.	.	.	.	.	.	.	.	.	.	.	.	
6	.	.	.	.	.	.	.	.	.	.	.	.	.	.	.	

- Vertical Display Screen Scrolling

**MM-1-1-2 (Scroll down to access)**

PHASE	COMPATIBILITY														^	
	6	5	4	3	2	1	0	9	8	7	6	5	4	3	2	
1	.	.	.	.	.	.	.	.	.	.	.	.	.	.	.	.
2	.	.	.	.	.	.	.	.	.	.	.	.	.	.	.	.
3	.	.	.	.	.	.	.	.	.	.	.	.	.	.	.	.
4	.	.	.	.	.	.	.	.	.	.	.	.	.	.	.	.
5	.	.	.	.	.	.	.	.	.	.	.	.	.	.	.	.
6	.	.	.	.	.	.	.	.	.	.	.	.	.	.	.	.
7	.	.	.	.	.	.	.	.	.	.	.	.	.	.	.	.
8	.	.	.	.	.	.	.	.	.	.	.	.	.	.	.	.
9	.	.	.	.	.	.	.	.	.	.	.	.	.	.	.	.
10	.	.	.	.	.	.	.	.	.	.	.	.	.	.	.	.
11	.	.	.	.	.	.	.	.	.	.	.	.	.	.	.	.
12	.	.	.	.	.	.	.	.	.	.	.	.	.	.	.	.
13	.	.	.	.	.	.	.	.	.	.	.	.	.	.	.	.
14	.	.	.	.	.	.	.	.	.	.	.	.	.	.	.	.
15	.	.	.	.	.	.	.	.	.	.	.	.	.	.	.	.

For MM-1-1-2, Phase Compatibility, scroll the display up/down to view and/or edit the compatibility data for phases 7 thru 15.

With *ASC/3* (16-line display), you only need to scroll to access the last line.

## Illustrations of the Full Screen

The viewing area of the *ASC/3* controller is limited to 40 characters wide by 16 lines high; the *2070* display is limited to 40 characters wide by 8 lines high. This manual usually shows full screens, as if there were no limit on the physical size of the display.

The full screen for MM-6-6 is shown below.

### MM-6-6 (Scroll down to access)

PED DETECTOR DIAG PLAN[1]				
DET	COUNTS	ACT	PRES	MULTIPLIER
1	0	0	0	1
2	0	0	0	1
3	0	0	0	1
4	0	0	0	1
5	0	0	0	1
6	0	0	0	1
7	0	0	0	1
8	0	0	0	1
9	0	0	0	1
10	0	0	0	1
11	0	0	0	1
12	0	0	0	1
13	0	0	0	1
14	0	0	0	1
15	0	0	0	1
16	0	0	0	1

At times, as shown in MM-6-5 below, some data is not shown (in this case, Detector numbers 9 through 63). Here, it is understood that the same pattern repeats and it is not necessary to illustrate every line.

### MM-6-5 (Detectors 9 thru 63 not shown)

VEH	DET	DIAG					V
VEH	DIAG	PLAN	NUMBER [ 1 ]	FAILED			
DET	COUNT	ACT	PRES	X'S	TIME	CL	DELAY
1	255	255	255	60	255	255	
2	0	0	0	1	0	0	
3	0	0	0	1	0	0	
4	0	0	0	1	0	0	
5	0	0	0	1	0	0	
6	0	0	0	1	0	0	
7	0	0	0	1	0	0	
8	0	0	0	1	0	0	
// (DET 9 through 63 are not shown)							
64	0	0	0	1	0	0	

- 2070 and ASC/3 Fast Display Navigation

## 2070 and ASC/3 Fast Display Navigation

To be compatible with *ASC/3*, most screens are designed as 16 lines or less.

### 2070

When you go to a screen that has more than 8 lines (such as MM-7-1), the first display that comes into view shows the top 8 lines, as shown below:

```

CONTROL [CORD SYS P120] MM/DD/YY|HH:MM:SS
  PHASE 1 2 3 4 5 6 7 8 9 0 1 2 3 4 5 6
PH STAT . G R R G R R R - - - - -
VEH OVL R G R - - - - -
PED STAT - D - C - D - D - - - - -
VEH CALL . I I . . . . .
PED CALL . . . . .
PLAN SPLT:.12|TP:. |SEQ:. |ACT: |DP:

```

### To show the bottom half of the screen:

- ▶ Press **NEXT**:

```

R1/PH 04|R2/PH 08|R3/PH ..|R4/PH ..
MGR1 0.0|YEL 0.0|INACTIVE |INACTIVE
PDCL 12.0|FORCE OFF|
DEN00/000|DEN00/000|DEN00/000|DEN00/000
MAX 00.0|MAX 00.0|MAX 00.0|MAX 00.0
OLA G . |OLB Y 2.9|OLC R . |OLD R .
FUNCTION 1 2 3 4 5 6 7 8 9 0 1 2 3 4 5 6
LP FLAG . A . . . A . . . . .

```

### To go back to the top display:

- ▶ Press **NEXT** again.

### ASC/3

When you go to a screen that has more than 16 lines, the first display that comes into view shows the top 16 lines.

### To show the next (up to 16) lines:

- ▶ Press **NEXT SCREEN**.

## Help Screen Navigation

### To navigate if Help has more than one screen/page:

- ▶ You can scroll one line at a time with the up/down arrow keys.
- ▶ To go to the first page from the last page, press **NEXT SCREEN**.



## Cursor Movement from the End of a Line

**When the cursor is on the far left of a line:**

**To move the cursor to the far right of the line above:**

- ▶ Press the left arrow key.

**Similarly, when the cursor is on the far right of a line:**

**To move the cursor to the far left of the line below:**

- ▶ Press the right arrow key.

## Hyperlink Field Navigation

With a hyperlink, you can go directly to a related display, then back to the original display. For example, from a status screen field with a hyperlink, the hyperlink takes you to the data entry screen for that field.

Hyperlink fields are shaded black<sup>1</sup>, as shown in five places below in screen MM-7-1.

**Note** • For each screen with hyperlink fields, navigation instructions for the hyperlinks are given in a procedure box to the right as shown below.

### MM-7-1, with five hyperlink fields

```
CONTROL[CORD SYS P120] MM/DD/YY|HH:MM:SS
  PHASE 1 2 3 4 5 6 7 8 9 0 1 2 3 4 5 6
PH STAT . G R R G R R R - - - - -
VEH OVL R G R - - - - -
PED STAT - D - C - D - D - - - - -
VEH CALL . I I . . . . .
PED CALL . . . . .
PLAN SPLT: 12|TP: 4|SEQ: 1|ACT: 100|DP:4
R1/PH 04|R2/PH 08|R3/PH ..|R4/PH ..
MGR1 0.0|YEL 0.0|INACTIVE |INACTIVE
PDCL 12.0|FORCE OFF| |
DEN00/000|DEN00/000|DEN00/000|DEN00/000
MAX 00.0|MAX 00.0|MAX 00.0|MAX 00.0
OLA G . |OLB Y 2.9|OLC R . |OLD R .
FUNCTION 1 2 3 4 5 6 7 8 9 0 1 2 3 4 5 6
LP FLAG . A . . . A . . . . .
```

When in a **hyperlink** field:

**To follow the hyperlink:**

For ASC/3, press **SPEC FUNC**, then **NEXT DATA**.

For 2070, press **B**.

**To go back:**

For ASC/3, press **SUB MENU**.

For 2070, press **ESC**.

<sup>1</sup>. To disable/enable the black hyperlink shading on a screen, press **SPEC FUNC** five times. In *ASC/3-LX* Ver. 32.59.00, hyperlink fields operate, but they are *not* shaded black as shown in this manual.

▪ *Normally Inaccessible Screens*

**To go to the hyperlinked display:**

- 1** Put the cursor in the black hyperlink field.
- 2** For an *ASC/3*, press **SPEC FUNC**, then press **NEXT DATA**.

**Or**

For a *2070*, press **\***, then press **D**.

**To go back to the original display:**

- ▶ For an *ASC/3*, press **SUB MENU**.

**Or**

- ▶ For a *2070*, press **ESC**.

**When the cursor is *not* in a hyperlink field, to go to the next hyperlink field:**

- ▶ For an *ASC/3*, press **SPEC FUNC**, then press **NEXT DATA**.

**Or**

- ▶ For a *2070*, press **\***, then press **D**.

**If there is another non-consecutive hyperlink field, to go to the next hyperlink:**

- ▶ For an *ASC/3*, press **> + SPEC FUNC + NEXT DATA**.

**Or**

- ▶ For a *2070*, press **> + \* + D**.

**To turn the black highlight on or off:**

- ▶ For an *ASC/3*, press **SPEC FUNC** five times within four seconds.

**Or**

- ▶ For a *2070*, press **\*** five times within four seconds.

## *Normally Inaccessible Screens*

To see some display screens, you do *not* press keys (MM-1-2-3 etc.). These special screens come into view automatically, as applicable.

These screens include the Power On screens and the Hardware Diagnostic screens:

- The Power On screens are the first screens shown in Appendix B, *ASC/3 Screens* on page B-1.
- The Hardware Diagnostic screens are shown in Appendix F, *ASC/3 Hardware Diagnostic Screens* on page F-1.

---

# Configuration

## Transaction Mode

---

**IMPORTANT** • To program an *ASC/3* or a *2070 Controller with ASC/3-2070* or *ASC/3-LX* software, it is necessary for you to understand Transaction Mode. Before you proceed, read and understand this section about Transaction Mode.

---

### *Introduction*

An *ASC/3* Controller contains a wide variety of Traffic features designed to give you maximum flexibility in configuring an intersection. This broad base of applications requires database functions which, in many cases, depend on other data entries to work properly. To ensure that critical data is entered properly, the controller must run consistency checks on the database. These tests make sure interrelated database functions are compatible with each other.

The consistency checks are done in what is called “Transaction Mode”.

Some data is relatively independent, such as timing entries. Other data, like the selection of controller startup phases, depends on the phases and compatibilities of programmed sequence. These data must be done within the Transaction Mode. Another type of data that triggers Transaction Mode is one that has 2 or more functions — examples include HH:MM or 10.70.10.51.

Controller data may be modified manually via the keypad or remotely using SNMP/STMP messages. In either case, critical data must be protected from incorrect or inconsistent changes.

### *Changing Data with the Keypad*

If you attempt to modify a critical piece of data with the keypad (for example, controller start-up phases), the controller automatically goes to Transaction Mode. A warning message will appear on the display and the top line of the screen will flash. At this point, all changed data is stored in a *temporary* buffer until you exit Transaction Mode.

- *Changing Data with the Keypad*

When the *ASC/3* is in Transaction Mode, the controller gives you audio-visual indications as explained below:

- As a reminder, if there is no key activity for 30 seconds, the controller will produce a continuous beep sound and a pop-up reminder message will be displayed. This reminder is the same as the message seen when you first triggered transaction mode and serves as a reminder to users who might not remember how to exit transaction mode. Any key activity will stop the buzzer but only the **CLEAR** key will clear the transaction mode message.
- The front-panel LED will blink:
  - **Fast Yellow** with *ASC/3-2100*, *ASC/3-1000*, and *ASC/3-RM*

**Or**

  - **Fast Red** with a *2070* controller with *ASC/3-2070* or *ASC/3-LX* software

For a complete list of the different modes for the *ASC/3* front-panel LED, refer to *Front Panel LED Indicator* on page 14-1. To select the LED Mode, refer to *Display Options, MM-1-7-2* on page 6-53 in the description of the LED MODE parameter.

### To exit Transaction Mode without saving the data:

- ▶ For *ASC/3*, press **SPEC FUNC** and then **CLEAR**.

**Or**

- ▶ For *2070*, press **\*** and then **C**.

### To initiate the VERIFY state, once you have completed all of the changes:

- ▶ For *2070*, press **SPEC FUNC** and then **ENTER**.

**Or**

- ▶ For *2070*, press **\*** and then **ENT**.

During the verify state, the controller runs its consistency checks on the newly entered data. If the data passes, then the changes are copied to the active database and Transaction Mode is terminated. If the Consistency Checks find an error (for example, incompatible Startup Phases), then the controller displays a description of the problem and gives you the option to disregard/throw away all changes or to go back into Transaction Mode to correct the data.

Although the controller's display will show your changes, it is important to note that those changes will NOT take effect in the controller's operation until Transaction Mode has exited. Also, if you cycle power during Transaction Mode, then upon start-up all modified data will be lost. This is because the modified data was only stored in the temporary buffer and never officially copied to the database.

Please note that not all data changes force the controller to Transaction Mode. Timing parameters such as Minimum Green and Yellow Clearance may be modified as soon as you enter the data. These changes take effect immediately.

## Changing Data with SNMP/STMP

You may also change the *ASC/3* database with an SNMP or STMP SET message from Central. In this case, it is Central's responsibility to force the controller into Transaction Mode if critical data is to be modified. Before SETs will be accepted on any P2 (or critical) objects, Central must send a SET to `dbCreateTransaction.0`, changing it to a value of *2-transaction*. At this point, Central may send any number of SETs to database objects. These values are stored in a temporary buffer, the same as with the manual keypad entry.

Once Central has completed its SNMP/STMP SETS and is ready to commit the new data to the database, Central must send a *3-Verify* to `dbCreateTransaction.0`. The *ASC/3* will run the same Consistency Checks as for the Keypad entry. Once completed, the controller internally sets the transaction state to 6-DONE. If no errors were found, the new data is automatically copied to the active database. Otherwise, the data is held in the temporary buffer until the discrepancies have been corrected. (Central can see the error messages by doing a GET on the object, `dbVerifyError.0`.)

## Summary

The *ASC/3* contains many database elements which are dependent on other entries. To ensure proper controller operations, these dependencies must be checked before data is committed to the active database.

Two methods exist to modify the controller's database- keypad and NTCIP communications. Both require the *ASC/3* or *2070* to enter a Transaction Mode state to allow Consistency Checks to run on the modified data. If you cycle power BEFORE these checks can be run, then the modified data will be lost.

Also note that while the changes may appear on the controller's screens, those values will NOT be implemented in the controller's operation until Transaction Mode is complete. That is, the Consistency Check must be done before the new data is officially copied to the database.

- *Automatic Backup to Datakey*

## Automatic Backup to Datakey

This feature allows automatic back up of configuration data 20 minutes after any change is made to the database from any source. This requires the Datakey be installed. You can enable this feature in MM-1-7-1. Refer to *Administration, MM-1-7-1* on page 6-49.

## Automatic Backup to Flash

### ASC/3 Backup

Data changes will be backed up to flash 5 seconds after the last data change.

### 2070 Backup

Data changes will be backed up at 3 am to the flash memory of the controller.

---

**Note** • Changes are always saved to super-cap backup NVRAM within 15 seconds after the last change.

---

## Configuration Submenu, MM-1

CONFIGURATION SUBMENU	
1. CONTROLLER SEQ	5. COMMUNICATIONS
2. PHASE IN USE/PED	6. ENABLE LOGGING
3. LOAD SW ASSIGN	7. DISPLAY/ACCESS
4. PORT 1 (SDLC)	8. LOGIC PROCESSOR

## Controller Sequence Submenu, MM-1-1

**IMPORTANT** • Do not change the controller sequencing while the controller is in operation on the street. Make sure the controller is in flash or on the bench before you change the sequencing.

### Programming Summary

CONTROLLER SEQUENCE SUBMENU
1. PHASE RING SEQUENCE AND ASSIGNMENT
2. PHASE COMPATIBILITY
3. BACKUP PREVENT PHASES
4. SIMULTANEOUS GAP PHASES
5. DIAMOND SEQUENCE 17 TO 20

MM-1-1 Menu Option	Programming Summary
1. PHASE RING SEQUENCE AND ASSIGNMENT	Assigns phase sequences and phase ring assignments.
2. PHASE COMPATIBILITY	Assigns the compatibility of phases. Compatibility is defined as those phases that can time together.
3. BACKUP PREVENT	Assigns phases that are prevented from backing up. Also selects the action that is to take place when a phase needs to backup.
4. SIMULTANEOUS GAP	Assigns phases that must gap at the same time to allow servicing a conflicting phase.
5. DIAMOND SEQUENCE 17 TO 20	Diamond Sequence menu is only active when Diamond Configuration is enabled.

- Phase Ring Sequence and Assignment, MM-1-1-1

## Phase Ring Sequence and Assignment, MM-1-1-1

**IMPORTANT** • Do not change the controller sequencing while the controller is in operation on the street. Make sure the controller is in flash or on the bench before you change the sequencing.

There are two possible sequence data entry modes: Barrier or Compatibility. These modes are referred to as B Mode or C Mode. The mode is indicated by either Bs or Cs on Line 4 of MM-1-1-1.

### To easily switch between Barrier (B) mode and Compatibility (C) mode:

- 1 Move the cursor to the SEQUENCE COMMANDS field in Line 2.
- 2 Toggle to the applicable command.
- 3 To execute, press **ENTER**.

In B Mode, phase order-of-rotation, ring assignment and barrier position (showing compatibility) are all controlled by data entry in MM-1-1-1. Active phases (Phases In Use) are programmed in MM-1-2. This makes it much easier to program single controller sequences using full barriers. This mode also supports multiple logical controllers if all are single-ring controllers. The Econolite default database is in B-mode.

In C Mode, phase order-of rotation and ring assignment is programmed on MM-1-1-1 and compatibility is programmed on MM-1-1-2. Active phases (Phases In Use) are programmed in MM-1-2. This mode must be used if the controller has multiple logical controllers and any logical controller has 2 or more rings, sequences with partial barriers, or “no serve” phases.

## B Mode Programming

### MM-1-1-1

```

CONTROLLER SEQUENCE [ 1]
SEQUENCE COMMANDS . HW ALT SEQ ENA. NO
    01 02 03 04 05 06 07 08 09 10 11 12 13 14 15 16
BC-B - B - B - - - - - - - - - - - - - - -
R1- 01 02 03 04 . . . . . . . . . . . . . . .
R2- 06 05 07 08 . . . . . . . . . . . . . . .
R3- . . . . . . . . . . . . . . . . . . . . .
R4- . . . . . . . . . . . . . . . . . . . . .

R1-R4=RING 1-4, DATA ENTRY, PHASES 1-16
BC=BARRIER CONTROL, VALUES: B,C
B= BARRIER MODE
C=COMPATIBILITY MODE
    
```



**To do B Mode programming:**

- 1 Go to MM-1-1-1 and make sure CONTROLLER SEQUENCE is set to 1. You should only modify Sequence 1 in B Mode.
- 2 If not in B Mode already, go to SEQUENCE COMMANDS field to switch to B Mode.
- 3 Position the cursor on Line 4 wherever a barrier will occur. Be sure to leave enough positions between barrier positions to allow entry of phases between barriers.
- 4 Position the cursor to the right of the Ring to be assigned. Press a Number Key (1-16) to assign the phase to the specified ring. Enter 0 (zero) if there is no other phase in the ring before the next barrier.

---

**Note** • Phase Ring assignments can be made in any order. The order defines service order.

---

- 5 To remove a phase ring assignment, enter 0 (zero).

---

**Note** • MM-1-1-2 (Phase Compatibility) is *not* required. MM-1-1-2 is not accessible in “B” mode.

---

**C Mode Programming**

**MM-1-1-1**

```

CONTROLLER SEQUENCE [ 1]
SEQUENCE COMMANDS . HW ALT SEQ ENA. NO
    01 02 03 04 05 06 07 08 09 10 11 12 13 14 15 16
BC-C C C C C C C C C C C C C C C
R1- 01 02 03 04 . . . . . . . . . .
R2- 06 05 07 08 . . . . . . . . . .
R3- . . . . . . . . . . . . . .
R4- . . . . . . . . . . . . . .

R1-R4=RING 1-4, DATA ENTRY, PHASES 1-16
BC=BARRIER CONTROL, VALUES: B,C
B=CURRENT GROUP RING BARRIER
C=COMPATIBILITY PROGRAMMED BY MAIN MENU 1-1-2
    
```

**To do C Mode programming:**

- 1 If not already in “C” mode, go to MM-1-1-1 SEQUENCE COMMANDS field to switch to the desired “C” mode.
- 2 Position the cursor to the right of the Ring to be assigned. Press a Number Key (1-16) to assign the phase to the ring.

## Configuration

---

- *Phase Ring Sequence and Assignment, MM-1-1-1*

---

**Note** • Phase Ring assignments can be made in any order, but no gap is allowed between phases (the entries must be contiguous).

---

- 3** If you enter **0** (zero), it removes a phase ring assignment.

---

**Note** • Phase compatibility is determined by programming in MM-1-1-2.

---

MM-1-1-1 Parameter	Description	Range
CONTROLLER SEQUENCE	<b>Controller Sequence</b> Phase order-of-rotation by ring. NTCIP 1202 2.8.3 <b>1-16:</b> Selects the programmed phase sequence (1-16) to use with the controller.	1-16

MM-1-1-1 Parameter	Description	Range
CONTROLLER SEQUENCE (cont'd)	<p>If you have a factory default database, the sequences are as listed below:</p> <p><b>Econolite factory default controller phase sequences:</b></p> <ul style="list-style-type: none"> <li>■ 1 - Standard Quad.</li> <li>■ 2 - Alt Seq A reverses phases 1-2 &amp; 9-10.</li> <li>■ 3 - Alt Seq B reverses phases 3-4 &amp; 13-14.</li> <li>■ 4 - Alt Seq A &amp; B reverse phases 1-2, 3-4, 9-10 &amp; 13-14.</li> <li>■ 5 - Alt Seq C reverses phases 5-6 &amp; 11-12.</li> <li>■ 6 - Alt Seq A &amp; C reverse phases 1-2, 5-6, 9-10 &amp; 11-12.</li> <li>■ 7 - Alt Seq B &amp; C reverse phases 3-4, 5-6, 11-12 &amp; 13-14.</li> <li>■ 8 - Alt Seq A, B &amp; C reverse phases 1-2, 3-4, 5-6, 9-10, 11-12 &amp; 13-14.</li> <li>■ 9 - Alt Seq D reverses phases 7-8 &amp; 15-16.</li> <li>■ 10 - Alt Seq A &amp; D reverse phases 1-2, 7-8, 9-10 &amp; 15-16.</li> <li>■ 11 - Alt Seq B &amp; D reverse phases 3-4, 7-8, 13-14 &amp; 15-16.</li> <li>■ 12 - Alt Seq A, B &amp; D reverse phases 1-2, 3-4, 7-8, 9-10, 13-14 &amp; 15-16.</li> <li>■ 13 - Alt Seq C &amp; D reverse phases 5-6, 7-8, 11-12 &amp; 15-16.</li> <li>■ 14 - Alt Seq A, C &amp; D reverse phases 1-2, 5-6, 7-8, 9-10, 11-12 &amp; 15-16.</li> <li>■ 15 - Alt Seq B, C &amp; D reverse phases 3-4, 5-6, 7-8, 13-14, 11-12 &amp; 15-16.</li> <li>■ 16 - Alt Seq A, B, C &amp; D reverse phases 1-2, 3-4, 5-6, 7-8, 9-10, 11-12, 13-14 &amp; 15-16.</li> </ul>	1-16
HW ALT SEQ ENA	<p><b>Hardware Alternate Sequence Enable</b></p> <ul style="list-style-type: none"> <li>■ <b>YES:</b> Enables the NEMA Alternate Sequence Hardware inputs (refer to TS2-2003, Table 3-12, page 113). If this parameter is enabled, the Power Start sequence programmed on MM-2-5 may be overwritten by these inputs (refer to the note below).</li> <li>■ <b>NO:</b> The NEMA Alternate Sequence hardware Inputs are ignored.</li> </ul> <p><b>Note</b> • This HARDWARE entry, if enabled, is selected according to the following hierarchy: SYSTEM, COORDINATION, TIME-BASE, HARDWARE.</p>	YES, NO

- Phase Ring Sequence and Assignment, MM-1-1-1

MM-1-1-1 Parameter	Description	Range
SEQUENCE COMMANDS	<p>(ECPI feature)</p> <ol style="list-style-type: none"> <li>1 Toggle to the applicable command.</li> <li>2 To execute, press <b>ENTER</b>.</li> </ol> <p>Refer to the command descriptions, below.</p> <p><b>COPY TO HIGHER SEQUENCE:</b> Copies the sequence shown to all, higher-numbered sequences. The screen will return to the default state (SEQUENCE COMMANDS) after copying and the CU will be in TRANSACTION MODE!</p> <p><b>Note</b> • The commands below are <i>only</i> available for Controller Sequence 1, NOT Controller Sequence 2 thru 16. The copy action will copy only Sequence Plans (MM-1-1-1) and Phase in Use (MM-1-2). It does not copy Load Switch Assignment (MM-1-3).</p> <p><b>SELECT B-MODE/DFT SEQUENCE:</b> Select Barrier mode and copy default Econolite phases for all 16 sequences. The screen will return to the default state (SEQUENCE COMMANDS) after copying and the CU will be in TRANSACTION MODE!</p> <p><b>SELECT C-MODE/DFT SEQUENCE:</b> Select Compatibility mode and copy default Econolite phases for all 16 sequences. The screen will return to the default state (SEQUENCE COMMANDS) after copying and the CU will be in TRANSACTION MODE!</p> <p><b>SELECT COMPATIBILITY MODE:</b> switching to compatibility from barrier mode without changing the sequence data. The screen will return to the default state (SEQUENCE COMMANDS) after copying and the CU will be in TRANSACTION MODE!</p> <p><b>SEL CUSTOM DFT SEQUENCE:</b> Copy Customer default Sequences from Customer default Database. If customer default Database does not exist, SELECT B-MODE/DFT SEQUENCE will be performed. The screen will return to the default state (SEQUENCE COMMANDS) after copying and the CU will be in TRANSACTION MODE!</p>	N/A

MM-1-1-1 Parameter	Description	Range
RING 1 RING 2 RING 3 RING 4	<p>RING PHASE SEQUENCE</p> <p>Defines the Ring to which a Phase is assigned.</p> <p>NTCIP 1202 2.8.3.3</p> <p>For rings 1-4 NTCIP 1202 2.2.2.22</p> <p><b>IMPORTANT</b> • <b>Do NOT change the ring assignments while the controller is in operation on the street. Be sure the controller is in flash or on the bench before you change this parameter.</b></p> <p><b>1-16:</b> assigns that phase to the ring for each of sixteen (1-16) sequences.</p> <p>The left-to-right order determines the order of rotation.</p> <p><b>0 (zero):</b> Removes the phase ring assignment and displays a “.”.</p> <p><b>Ring assignment requirements:</b></p> <ul style="list-style-type: none"> <li>■ A phase assigned to a ring in sequence one will also change the Phase-Ring-Assignment (NTCIP 1202 2.2.2.22).</li> <li>■ There can be no gaps in the ring assignments. If a phase is eliminated, all the phases to the right of it must be shifted left to close the gap. This must be done for all sequences.</li> <li>■ Sequences 2-16 must be consistent with the Phase-Ring-Assignment generated in sequence 1. Sequences are commanded using the NEMA alternate sequence inputs, Time Base or hardware inputs if enabled.</li> </ul>	<p>Phase 1-16 assigns Phase to a Ring</p> <p>0 removes Phase from Ring assignment</p>

### Phase Compatibility, MM-1-1-2

Phase compatibility defines the phases that can time concurrently (together):

- Pressing the Toggle, **0/YES**, alternately selects (X) or deselects (“.”) the phases that are compatible (allowed to time concurrently).
- Phases in the same ring cannot be compatible. Only phases in different rings can be compatible.

---

**Note** • If the controller is programmed in Barrier mode, this screen is not accessible. Refer to *Phase Ring Sequence and Assignment, MM-1-1-1* on page 6-6 for more details.

---

- Backup Prevent Phases, MM-1-1-3

**MM-1-1-2 (Standard Quad Shown)**

PHASE	COMPATIBILITY														
	6	5	4	3	2	1	0	9	8	7	6	5	4	3	2
1	.	.	.	.	.	.	.	.	.	.	.	.	.	.	.
2	.	.	.	.	.	.	.	.	.	.	.	.	.	.	.
3	.	.	.	.	.	.	.	.	.	.	.	.	.	.	.
4	.	.	.	.	.	.	.	.	.	.	.	.	.	.	.
5	.	.	.	.	.	.	.	.	.	.	.	.	.	.	.
6	.	.	.	.	.	.	.	.	.	.	.	.	.	.	.
7	.	.	.	.	.	.	.	.	.	.	.	.	.	.	.
8	.	.	.	.	.	.	.	.	.	.	.	.	.	.	.
9	.	.	.	.	.	.	.	.	.	.	.	.	.	.	.
10	.	.	.	.	.	.	.	.	.	.	.	.	.	.	.
11	.	.	.	.	.	.	.	.	.	.	.	.	.	.	.
12	.	.	.	.	.	.	.	.	.	.	.	.	.	.	.
13	.	.	.	.	.	.	.	.	.	.	.	.	.	.	.
14	.	.	.	.	.	.	.	.	.	.	.	.	.	.	.
15	.	.	.	.	.	.	.	.	.	.	.	.	.	.	.

**Backup Prevent Phases, MM-1-1-3**

A backup condition occurs when a phase is at rest and there is a call on a specified phase in the same ring. The Backup Prevent Phases screen programs the action that is to take place when a backup condition occurs.

ENABLE	BACKUP	PREVENT														
TMG\BKUP	1	2	3	4	5	6	7	8	9	0	1	2	3	4	5	6
1	.	.	.	.	.	.	.	.	.	.	.	.	.	.	.	.
2	B	.	.	.	.	.	.	.	.	.	.	.	.	.	.	.
3	.	.	.	.	.	.	.	.	.	.	.	.	.	.	.	.
4	.	C	B	.	.	.	.	.	.	.	.	.	.	.	.	.
5	.	.	.	.	.	.	.	.	.	.	.	.	.	.	.	.
6	.	.	.	.	B	.	.	.	.	.	.	.	.	.	.	.
7	.	.	.	.	.	.	.	.	.	.	.	.	.	.	.	.
8	.	.	.	.	.	C	B	.	.	.	.	.	.	.	.	.
9	.	.	.	.	.	.	.	.	.	.	.	.	.	.	.	.
10	.	.	.	.	.	.	.	.	X	.	.	.	.	.	.	.
11	.	.	.	.	.	.	.	.	.	.	.	.	.	.	.	.
12	.	.	.	.	.	.	.	.	.	X	.	.	.	.	.	.
13	.	.	.	.	.	.	.	.	.	.	.	.	.	.	.	.
14	.	.	.	.	.	.	.	.	.	.	.	.	.	.	.	.
15	.	.	.	.	.	.	.	.	.	.	.	.	.	.	.	.
16	.	.	.	.	.	.	.	.	.	.	.	.	.	.	.	.

**To inhibit (X)/enable (B or “.”) service to backup phase from the current phase:**

- ▶ Press toggle, 0/YES

Backup (B) will be through an enabled (C) phase or red revert. “.” allows normal non-restricted phase rotation.

In the standard Quad example shown:

- Phases 2/6 will backup through all-red in response to a call on phase 1 or 5.
- Phases 4/8 will backup through phase 2/6 in response to a call on phase 3 or 7.
- Phases 10/12 will not backup in response to a call on phase 9 or 10.
- Phases 14/16 will time nominally in response to calls on any phase.

MM-1-1-3 Parameter	Description	Range
X	X Inhibits the controller from servicing the BACKUP (column) phase when the "TIMING" (row) phase is active or next.	X inhibits
B without C	"B" without a "C" programmed for the timing phase, inhibits the controller from servicing the 'BACKUP' phase when the "TIMING" phase is active or next until the controller goes through red revert as described in NEMA TS2 3.5.5.7 and RED CLEAR as described in NEMA TS2 3.5.4.2.	B without C Inhibits
B with C	"B" with a "C" programmed for the timing phase, places a demand on that "BACKUP" (column) phase. The controller will then service the called phase and proceed normally.	B with C enables

### Simultaneous Gap Phases, MM-1-1-4

**To select (X) or deselect (".") the phases that are to gap together:**

- ▶ Press Toggle, 0/YES

```

SIMULTANEOUS GAP PHASES
GAP\PH  1 2 3 4 5 6 7 8 9 0 1 2 3 4 5 6
  1 . . . . X X . . . . . . . .
  2 . . . . X X . . . . . . . .
  3 . . . . . X X . . . . . . . .
  4 . . . . . X X . . . . . . . .
  5 X X . . . . . . . . . . . . .
  6 X X . . . . . . . . . . . . .
  7 . . X X . . . . . . . . . . .
  8 . . X X . . . . . . . . . . .
  9 . . . . . . . . . X X . . . .
 10 . . . . . . . . . X X . . . .
 11 . . . . . . . . X X . . . . .
 12 . . . . . . . . X X . . . . .
 13 . . . . . . . . . . . . X X
 14 . . . . . . . . . . . . X X
 15 . . . . . . . . . . X X . .
 16 . . . . . . . . . . X X . .
DISABLE. . . . . . . . . . . . .
    
```

▪ *Simultaneous Gap Phases, MM-1-1-4*

Each row associates a phase (“row” phase) with the phases (“column” phases) it must simultaneously gap with when terminating together to service a conflicting demand. If the “row” phase is terminating to service a phase that is permissive with the “column” phases, then it will not wait to gap simultaneously with the “column” phases. If a “column” phase is not selected, it is allowed to gap independently with the “row” phase.

- 1 From the Controller Sequence submenu (MM-1-1), select Option #4 Simultaneous Gap and the Simultaneous Gap Phases screen (MM-1-1-4) appears.
- 2 Use Toggle **0/YES**, to insert an “X” or “.” where appropriate.
  - “X” indicates that when the row and column phases are required to terminate together because of Phase Compatibility (ref. MM-1-1-2), they must gap together.
  - “.” indicates that when the row and column phases are required to terminate together because of Phase Compatibility (ref. MM-1-1-2), they gap independently.

In the Quad example shown:

- Phases 1/5, 1/6, 2/5, and 2/6 gap together in response to a demand on phases 3, 4, 7-16.
- Phases 3/7, 3/8, 4/7, and 4/8 gap together in response to a demand on phases 1, 2, 5, 6, 9-16.
- Phases 9/11, 9/12, 10/11, and 10/12 gap together in response to a demand on phases 1-8, 13-16.

Phases 13-16 do not gap together in response to a demand on phases 1-12.

MM-1-1-4 Parameter	Description	Range
X	X on a (“row”) phase requires that it gaps with the (“column”) phase when terminating together to service a conflicting demand. If the either phase is terminating to service a phase that is permissive with the other/s then it will not wait to gap simultaneously with the “column” phase/s. When the column phase has not yet reached such a point, the row phase shall revert to the extendable portion and time passage intervals based on vehicle calls. The phases must be permitted to time concurrently.	X selects “.” deselects
“.”	“.” on the (“row”) phase allows it to gap independently with the (“column”) phase.	



## Diamond Configuration Information

To start Diamond Configuration, you must have a Diamond configured database loaded and active in the controller.

### To convert an ASC/3 Database to Diamond Configuration:

- 1 Open the database file using the *ASC/3* Configurator.
- 2 Click on the “Diamond Setting” check box. It should set all the programming values described in Appendix Q, *Diamond Intersection Application Notes*.

---

**IMPORTANT** • Before you proceed, note that the subsequent operation is **irreversible**—once a Diamond, it is always a Diamond.

---

- 3 Save the database with Diamond configuration.
- 4 Use the appropriate *ASC/3* utility to download the Diamond configured database to the controller.
- 5 You can perform additional Programming using the controller’s Front Panel/Keypad after the database is downloaded.

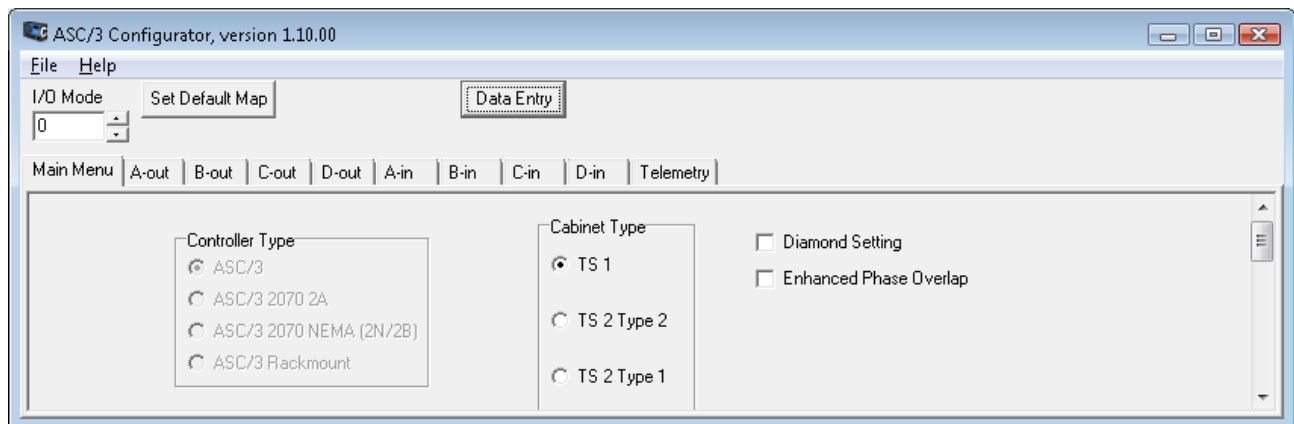

### To select a Diamond Database or a Standard Database:

- 1 Download the Diamond database with the *ASC/3* Utility.
- 2 Make sure this database is active.
- 3 Use MM-8-2 to perform “CONTROLLER DATA > DEFAULT DATABASE”
- 4 In MM-8-2, select:
  - Standard DB with “ECONOLITE DBASE > CONTROLLER DATA”

**Or**

  - Diamond DB with “DEFAULT DATABASE > CONTROLLER DATA”

▪ *Phases in Use/Exclusive Pedestrian*

For complete information on Diamond programming, refer to Appendix Q, *Diamond Intersection Application Notes*.

## Phases in Use/Exclusive Pedestrian

### Phases in Use, MM-1-2

Phases must be programmed IN USE to be active and able to use any assigned functions. This allows phases to be omitted from use without having to remove them from the phase sequence, phase compatibility, phase ring sequence, applying phase omit, deleting the assignment of detectors and/or recall functions through various data entry pages. When the phase is needed, it can be selected as active.

In the following example, the 16-phase quad is reduced to a standard 8-phase quad.

**To select phases for use:**

- 1 Use Toggle, **0/YES**, to select phase(s) in use.
- 2 Select with X under Phases 1-8 next to the IN USE parameter. To deselect, select “.”

PHASES IN USE / EXCLUSIVE PED									
	PHASE	1	2	3	4	5	6	7	8
IN USE.....		X	X	X	X	X	X	X	X
EXCLUSIVE PED		.	.	.	.	.	.	.	.
	PHASE	9	10	11	12	13	14	15	16
IN USE.....		.	.	.	.	.	.	.	.
EXCLUSIVE PED		.	.	.	.	.	.	.	.

### Exclusive Pedestrian Timing, MM-1-2

Applications that require phases only to time pedestrian intervals are programmed as Exclusive Pedestrian. An example is diagonal pedestrian crossings at an intersection where vehicle traffic is stopped in all directions and only pedestrian intervals are displayed to allow pedestrian traffic to cross in any number of directions at one time.

In this example, Phase 9 has been added to the 8-phase standard quad as an exclusive ped movement.

**To select exclusive pedestrian timing:**

- 1 Use Toggle, **0/YES**, to select exclusive pedestrian phase(s). Press key to indicate X under desired phase next to EXCLUSIVE PED parameter.
- 2 Enter pedestrian interval timing values as needed (Controller Submenu, Timing Data).

PHASES IN USE/EXCLUSIVE PED								
PHASE	1	2	3	4	5	6	7	8
IN USE.....	X	X	X	X	X	X	X	X
EXCLUSIVE PED	.	.	.	.	.	.	.	.

PHASE	9	10	11	12	13	14	15	16
IN USE.....	X	.	.	.	.	.	.	.
EXCLUSIVE PED	X	.	.	.	.	.	.	.

MM-1-2 Parameter	Description	Range
IN USE	Indicates phases to be active. A phase times intervals only when it is in use, so phases not selected are omitted from controller operation. This is not programmable if Barrier mode is used in MM-1-1-1.	X enables "." disables
EXCLUSIVE PED	Phases timing only pedestrian intervals without concurrent vehicle movement	X enables "." disables

## Load Switch Assignment (MMU CHANNEL), MM-1-3

LD SWITCH ASSIGN									
PHASE	DIMMING	---FLASH---							
/OVLP	TYPE	R	Y	G	D	PWR	AUT	TGR	
1	1	O	.	.	.	+	X	.	.
2	2	O	.	.	.	+	X	.	.
3	3	O	.	.	.	+	X	.	.
4	4	O	.	.	.	+	X	.	.
5	5	O	.	.	.	+	X	.	.
6	6	O	.	.	.	+	X	.	.
7	7	O	.	.	.	+	X	.	.
8	8	O	.	.	.	+	X	.	.
9	2	P	.	.	.	+	X	.	.
10	4	P	.	.	.	+	X	.	.
11	6	P	.	.	.	+	X	.	.
12	8	P	.	.	.	+	X	.	.
13	13	O	.	.	.	+	X	.	.
14	14	O	.	.	.	+	X	.	.
15	15	O	.	.	.	+	X	.	.
16	16	O	.	.	.	+	X	.	.

## Configuration

- Load Switch Assignment (MMU CHANNEL), MM-1-3

MM-1-3 Parameter	Description	Range
PHASE/OVLP	<p><b>1-16:</b> Assigns phase 1-16 or overlap A-P (respectively) indications (Green/Walk, Yellow/Ped Clear and Red/ Don't Walk) to that load switch and MMU channel.</p> <p><b>0 (zero):</b> deselects any control for that load switch.</p> <p><b>Note • “O” (overlap) 1-16 refer to overlaps A-P respectively.</b></p> <p>This assignment applies only to TS2 operation with a TS2 MMU. It provides the assignment of and correlation between the indication and MMU channel for verifying that the load switch output sensed by the MMU corresponds to the BIU command.</p> <p><b>Note • For TS2 operation unused load switch/MMU Channels should be cleared of all Phase/OVLP and TYPE programming.</b></p>	0 - 16
TYPE	<p><b>V:</b> Vehicle</p> <p><b>P:</b> Pedestrian</p> <p><b>O:</b> Overlap</p> <p><b>“.”:</b> NTCIP “Other” not defined</p> <p>This assigns the source of that load switch as a Vehicle, Overlap or Pedestrian indication (Walk, Pedestrian Clear, and Don't Walk) to that load switch and MMU channel.</p> <p>This assignment applies only to TS2 operation with a TS2 MMU. It provides the assignment of and correlation between the indication and MMU channel to make sure that the load switch output sensed by the MMU corresponds to the BIU command.</p> <p>This assignment also allows the controller to redundantly check and verify the load switch outputs indications as sensed by the MMU are as it commanded.</p>	V, P, O, “.”
DIMMING (R, Y, G)	<p><b>X:</b> Selects the load switch indication(s) that are to be dimmed when dimming is enabled.</p> <p><b>“.”:</b> Inhibits dimming of the load switch indication(s) when dimming is enabled.</p>	X, “.”
DIMMING (D)	<p><b>“+”:</b> Selects the positive 1/2 cycle for dimming</p> <p><b>“-”:</b> Selects the negative 1/2 cycle for dimming.</p> <p><b>Note • When dimming, the indication load current should be balanced for the positive and negative 1/2 cycles of the AC line.</b></p>	“+”, “-”

MM-1-3 Parameter	Description	Range
PWR	<p><b>Load Switch Power Up Flash Color</b></p> <p><b>A:</b> Indicates that the channel color will follow Automatic Flash. If any PWR is programmed R or Y, then the controller cannot have A programmed for any other PWR channels.</p> <p><b>Y:</b> Indicates that the channel will flash yellow. These load switches must represent compatible MMU channels.</p> <p><b>R:</b> Indicates that the channel will flash red. These load switches must represent compatible MMU channels.</p> <p><b>∴:</b> Indicates that the channel will be dark.</p> <p><b>IMPORTANT • It is your responsibility to match the PWR load switch setting on MM-1-3 with the actual cabinet flash output.</b></p>	A, Y, R, “∴”
AUT	<p><b>Load Switch Automatic Flash Color</b></p> <p><b>R:</b> Indicates that the channel will flash red. These load switches must represent compatible MMU channels.</p> <p><b>Y:</b> Indicates that the channel will flash yellow. These load switches must represent compatible MMU channels.</p> <p><b>∴:</b> Indicates that the channel will be dark.</p> <p><b>IMPORTANT • It is your responsibility to match the PWR load switch setting on MM-1-3 with the actual cabinet flash output.</b></p>	R, Y, “∴”
TGR	<p><b>Flash Together Indications</b></p> <p><b>X:</b> Phases selected with an X will flash on the alternate half Hertz.</p> <p><b>∴:</b> Phases selected with “∴” will flash on the half Hertz.</p> <p><b>Note • The load current during flashing should be balanced to provide a balanced load to the AC supply.</b></p>	X, “∴”

- Port 1 (SDLC) Submenu, MM-1-4

## Port 1 (SDLC) Submenu, MM-1-4

```
PORT 1 (SDLC) SUBMENU

1. SDLC OPTIONS

2. MMU PROGRAM

3. COLOR CHECK ENABLE

4. SECONDARY STATIONS/TESTS
```

### SDLC Options, MM-1-4-1

#### General

TS2 controllers use the Port 1 controller interface which connects to the Malfunction Management Unit (MMU), Terminals and Facilities (TF), and/or Detector (DET) rack. Synchronous Data Link Control (SDLC) protocol is used to communicate with various devices where the controller is the master and BIUs and MMU are slaves. Only the controller can send or request data from the BIUs or MMU. Up to eight TF BIUs, eight DET rack BIUs, and one MMU can be attached to the controller network.

```
SDLC PORT 1 CONFIG
      BIU  1  2  3  4  5  6  7  8
TERM & FACILITY  .  .  .  .  .  .  .  .
DETECTOR RACK   .  .  .  .  .  .  .  .

ENABLE TS2/MMU TYPE CABINET..... NO
ENABLE MMU EXTENDED STATUS..... NO
ENABLE SDLC STOP TIME..... NO
ENABLE 3 CRITICAL RFEs LOCKUP..... YES
MMU TO CU SDLC EXTERNAL START... ENABLED
```

---

**IMPORTANT** • If you incorrectly program TF BIUs or MMU Enable, the controller immediately goes into intersection flash.

---

#### Terminal and Facilities

Toggle to enable TF BIUs when the controller is operating in a NEMA TS2 Type 1 cabinet.

#### Detector Rack

Toggle to enable DET BIUs when the controller is operating in a NEMA TS2 Type 1 or Type 2 cabinet.

## MMU Type Cabinet

### Toggle to select:

- ▶ **YES** for NEMA TS2 installations

Or

- ▶ **NO** for NEMA TS1 installations
- For a NEMA TS2 Type 1 installation (TF BIUs enabled), the MMU communication is enabled, regardless of this programming.
- For a NEMA TS2 Type 2 installation (no TF BIUs enabled), the MMU communication must be enabled.
- For a NEMA TS1 installation no TF BIUs, DET BIUs, or MMU are enabled.

## SDLC Stop Time

---

**Note** • The MMU must be enabled for this option to be useable

---

### Use toggle key to select:

- ▶ **YES** to enable the MMU FAIL (output relay transferred) response to stop time the controller.
- Or
- ▶ **NO** to disable MMU FAIL response from stopping the controller timing. This option allows a cabinet STOP TIME: AUTO-OFF-ON switch to control the TF BIU stop time and/or the TS2 connector stop time input.

MM-1-4-1 Parameter	Description	Range
BIU 1-8	<p>These BIU numbers label the next two rows:</p> <ul style="list-style-type: none"> <li>■ For TERM &amp; FACILITY, BIU 1-8 refers to the Terminal and Facilities BIUs #1-8, which correspond to TS2 BIUs 1-8 respectively.</li> <li>■ For DETECTOR RACK, BIU 1-8 refers to the Detector Rack BIUs #1-8, which correspond to TS2 BIUs 9-16 respectively.</li> </ul> <p>Each BIU provides an interface between the controller's serial RS-485 SDLC link and discrete NEMA level I/O ports.</p>	<p>1-4 usable BIUs</p> <p>5-8 spare or reserved</p>

- SDLC Options, MM-1-4-1

MM-1-4-1 Parameter	Description	Range
TERM & FACILITY	<p>NEMA TS2 5.3.1.4, NEMA TS2 5.3.4.3</p> <p><b>X:</b> Enable Terminal &amp; Facility BIUs.</p> <p><b>.</b> : Disable Terminal &amp; Facility BIUs.</p> <p>Terminal &amp; Facility BIUs #1-4 are defined by NEMA.</p> <p>Each BIU provides an I/O interface between the controller unit and the cabinet through (SDLC) PORT 1. BIUs can be used in:</p> <ul style="list-style-type: none"> <li>▪ TS 2 Type 1 for Terminal &amp; Facility and Detector Rack.</li> <li>▪ TS 2 Type 2 for the Detector Rack only.</li> </ul>	<p>X enable BIU</p> <p>“.” disable BIU</p>
DETECTOR RACK	<p>NEMA TS2 5.3.1.4, NEMA TS2 5.3.4.3</p> <p><b>X:</b> Enable Detector Rack BIUs.</p> <p><b>.</b> : Disable Detector Rack BIUs.</p> <p>Detector Rack BIUs #1-4 are defined by NEMA.</p> <p>Each BIU provides an I/O interface between the controller unit and the cabinet through (SDLC) PORT 1. BIUs can be used in:</p> <ul style="list-style-type: none"> <li>▪ TS 2 Type 1 for Terminal &amp; Facility and Detector Rack.</li> <li>▪ TS 2 Type 2 for the Detector Rack only.</li> </ul>	<p>X enable BIU</p> <p>. disable BIU</p>
ENABLE TS2/MMU TYPE CABINET	<p>This is an ECPI Feature.</p> <p><b>NO:</b> For NEMA TS1 installations.</p> <p><b>YES:</b> For NEMA TS2 installations.</p> <ul style="list-style-type: none"> <li>▪ NEMA TS2 Type 1 (TF BIUs enabled), the MMU communication is enabled regardless of this programming.</li> <li>▪ NEMA TS2 Type 2 (No TF BIUs enabled), the MMU communication must be enabled.</li> </ul> <p><b>Note</b> • This field is treated as YES for an ASC/3-1000 controller type, regardless of the setting. To disable all Port 1 Communications (for bench test), put a jumper between Pin 2 and Pin 10 on the SDLC port.</p>	<p>YES enables</p> <p>NO disables</p>



MM-1-4-1 Parameter	Description	Range
ENABLE MMU EXTENDED STATUS	<p>This is an ECPI Feature.</p> <p><b>NO:</b> Disable MMU Extended Status.</p> <p><b>YES:</b> Enable Extended MMU Status on MM-7-7-4 and MM-7-7-5.</p> <p><b>Note</b> • <b>MMU Extended Status (RF 192/RF 202) is supported on Econolite, EDI and Reno controllers. Please use extra caution if you enable this feature on other types of MMU.</b></p>	<p>YES enables</p> <p>NO disables</p>
ENABLE SDLC STOP TIME	<p>This is an ECPI Feature.</p> <p><b>YES:</b> Enables the MMU in a FAIL condition to apply Stop Time to the CU through the SDLC.</p> <p><b>NO:</b> Disables the MMU in a FAIL condition so it does NOT apply Stop Time to the CU through the SDLC.</p> <p><b>Note</b> • <b>TS2/MMU TYPE CABINET is treated as YES for ASC/3-1000 controller type.</b></p> <p>To simulate <i>ASC/3-2100</i>, put a jumper between pin 2 and 10 on SDLC port.</p>	<p>YES enables</p> <p>NO disables</p>
ENABLE 3 CRITICAL RFEs LOCKUP	<p><b>Enable Critical RFE Failure Lockup</b></p> <p>This is an ECPI Feature.</p> <p><b>NO:</b> Disables latching of the 3<sup>rd</sup> critical RFE within 24 hours.</p> <p><b>YES:</b> Controller will latch the 3<sup>rd</sup> critical RFE within 24 hours as required by NEMA TS2-2003, 3.9.3.1.3 Port 1.</p> <p><b>Note</b> • <b>A critical RFE occurs when more than 5 of the last 10 critical response frames are not received.</b></p>	<p>YES disables</p> <p>NO enables</p>
MMU TO CU SDLC EXTERNAL START	<p>The default is ENABLED.</p> <p><b>Note</b> • <b>After 90 minutes or a power cycle, if the function is NOT set to ENABLED or DISABLED, then the value will be set to ENABLED. This is to make sure that this function is always enabled unless explicitly disabled by the user.</b></p>	<p>ENABLED, DISABLED, 90 MIN</p>

- MMU Compatibility Programming, MM-1-4-2

## MMU Compatibility Programming, MM-1-4-2

MMU PROGRAM [MANUAL]	ERROR															
MMU	CH	6	5	4	3	2	1	0	9	8	7	6	5	4	3	2
1	.	.	.	.	.	.	.	.	.	.	.	.	.	.	.	.
2	.	.	.	.	.	.	.	.	.	.	.	.	.	.	.	.
3	.	.	.	.	.	.	.	.	.	.	.	.	.	.	.	.
4	.	.	.	.	.	.	.	.	.	.	.	.	.	.	.	.
5	.	.	.	.	.	.	.	.	.	.	.	.	.	.	.	.
6	.	.	.	.	.	.	.	.	.	.	.	.	.	.	.	.
7	.	.	.	.	.	.	.	.	.	.	.	.	.	.	.	.
8	.	.	.	.	.	.	.	.	.	.	.	.	.	.	.	.
9	.	.	.	.	.	.	.	.	.	.	.	.	.	.	.	.
10	.	.	.	.	.	.	.	.	.	.	.	.	.	.	.	.
11	.	.	.	.	.	.	.	.	.	.	.	.	.	.	.	.
12	.	.	.	.	.	.	.	.	.	.	.	.	.	.	.	.
13	.	.	.	.	.	.	.	.	.	.	.	.	.	.	.	.
14	.	.	.	.	.	.	.	.	.	.	.	.	.	.	.	.
15	.	.	.	.	.	.	.	.	.	.	.	.	.	.	.	.

### Feature Summary

The *ASC/3* controller can be programmed as standard with MMU (Malfunction Management Unit) channel compatibility data identical to that programmed on the MMU Programming Card described in Paragraph 4.3.6, *Control and Programming*, Figure 4-1, of the NEMA TS 2-2003 standards document. The purpose of the MMU Compatibility feature is to prevent accidental installation of an MMU with incorrect channel programming in a live intersection. An additional benefit, using the AUTO mode, is to help the user program the MMU Program Card.

If enabled and programmed, this feature will cause the controller to activate the Voltage Monitor/Fault Monitor outputs if there is any mismatch between the program stored in the controller and the program on the MMU Program Card. If incompatibility is detected, an ERROR indicator comes into view to help you to correctly program the MMU. This feature is enabled when:

- The field “ENABLE TS2/MMU TYPE CABINET” in MM-1-4-1 is set to “YES” and
- There is channel compatibility information programmed in MM-1-4-2. If this occurs, a status screen (MM-7-7-6) lets you determine the exact nature of a channel mismatch.

In summary, this feature:

- Lets you set internal MMU compatibility programming using one of three methods (MANUAL, AUTO, COPY MMU). Also, there is a CLEAR function to clear out the data.
- Compares internal compatibility programming to programming on the MMU Program Card and sets Voltage Monitor/Fault Monitor outputs if there is a mismatch between the two.

MM-1-4-2 (shown above) is visible only if the field “ENABLE TS2/MMU TYPE CABINET” in MM-1-4-1 is set to “YES”. If the value is “NO,” the screen will be blank with the message “MMU DISABLED IN MM-1-4-1.”

### MMU Program Mode Selection

If the MMU is enabled, you can toggle between MANUAL, AUTO, CLEAR and COPY:

#### To toggle the MMU PROGRAM field:

- 1 Move the cursor to this field.
- 2 Press **0**/TOGGLE.

---

**Note** • The field selection is acted on *only* when you press ENTER.

---



---

**IMPORTANT** • Use this menu with care because it can cause the cabinet to go into flash.

---

MM-1-4-2 Parameter	Description	Notes
MANUAL	Manually enter channel compatibility information	<p>If you select MANUAL compatibility programming, any change to MM-1-4-2 in a controller installed in a live cabinet will almost certainly result in CVM FLASH. You should program the controller in your shop before cabinet installation, or place a live cabinet in LOCAL FLASH before you make changes.</p> <p>If you select this, the data entry is set to MANUAL, by default.</p> <p>To manually enter channel compatibility, move the cursor over an array position and press <b>0</b> (toggle). Each toggle will alternately cause the array position to switch between “.” and “X”.</p> <p>If there are no programmed compatibility points, the MMU Compatibility feature is disabled.</p>

▪ MMU Compatibility Programming, MM-1-4-2

MM-1-4-2 Parameter	Description	Notes
AUTO	Automatically compute channel compatibility based on <i>ASC/3</i> programming (the AUTO mode)	<p>The use of AUTO mode is highly recommended to set internal <i>ASC/3</i> compatibility programming and as a guide for MMU Program Card programming. There is the remote possibility the AUTO computations would not pick up every channel compatibility point because of very complex <i>ASC/3</i> programming. In this case, AUTO mode can be used to generate most of the programming. You can then switch to MANUAL mode to fine-tune programming. Automatic computations are based on an enabled MMU and take into consideration phases-in-use, phase concurrency, valid pedestrian movements, vehicle and pedestrian overlaps, and pedestrian carryover. To obtain phase-to-channel information, refer to <i>Load Switch Assignment (MMU CHANNEL), MM-1-3</i> on page 6-17. If you select this, the data entry is set to AUTO, which has the value of 1 in the database.</p> <p>When selected, the controller automatically computes <i>ASC/3</i> channel compatibility based on:</p> <ul style="list-style-type: none"> <li>■ Vehicle/pedestrian/overlap channel assignments (MM-1-3).</li> <li>■ Phases in use (MM-1-2).</li> <li>■ Phase sequencing (MM-1-1-2 and/or MM-1-1-1).</li> <li>■ Vehicle and pedestrian overlaps (MM-2-3).</li> <li>■ Pedestrian carryover (MM-2-1, field “PED CO”).</li> </ul> <p>In AUTO mode, “X” will be shown at channel compatibility points if the channel outputs can be on at the same time and “.” if they cannot. The user will not be able to change the compatibility array in AUTO mode.</p> <p>If you first select AUTO mode, then select MANUAL mode, the AUTO channel compatibility will be copied to the MANUAL screen. This allows you to automatically populate the array in AUTO mode and move the results to the MANUAL screen.</p>
COPY MMU	Copy the programming from the MMU Programming Card	<p>The content of the MMU Programming Card is copied to the compatibility array. Then the controller returns to the MANUAL mode.</p> <p>The use of COPY MMU is not recommended unless you are 100% sure the MMU Program Card is correct.</p>

MM-1-4-2 Parameter	Description	Notes
CLEAR	Clear the compatibility table	This function is a command. Its value is not stored in the database. Channel compatibility programming is cleared and the user is returned to MANUAL mode. This will disable the MMU Compatibility feature until compatibility points are again programmed using the MANUAL, AUTO or COPY MMU modes.

**Status Screen, MM-7-7-6 (hyperlinked with MM-1-4-2)**

```

MMU COMPATIBILITY STATUS MFG: EDI/RENO
  CH|6 5 4|3 2 1|0 9 8|7 6 5|4 3 2
  1 . . . . M X . . . . X X . . .
  2 . . . . . X . X . . X X . . .
  3 . . . . X . . . X X . . . .
  4 . . . . X . X . X X . . .
  5 . . . . . . . C . . . .
  6 . . . . . X . X . . .
  7 . . . . . X . . . .
  8 . . . . X . X . . .
  9 . . . . . X . . . .
 10 . . . . X . . . .
 11 . . . . . . . . .
 12 . . . . . . . . .
 13 . . . . . . . . .
 14 . . . . . . . . .
 15 . . . . . . . . .
    
```

In this sample Status Screen, assume the ASC/3 has the STD database. Channels 1 through 8 are assigned phases 1 through 8 and channels 9 through 12 are assigned pedestrian movements 2, 4, 6 and 8, respectively. The x's indicate MMU Programming Card and the controller compatibility programming match points. Note, however, that the channel 1/12 compatibility point contains an "M" and the channel 5/9 compatibility point contains a "C". The "M" indicates the MMU Programming Card has a jumper incorrectly installed at this point. The "C" indicates the CU has determined these two channels will be on together, but the point is not jumpered on the MMU Programming Card.

**MFG**

This field will display the manufacturer of the MMU, where:

- EDI = Eberle Design, Inc.
- RENO = Reno A&E, Inc.

- Color Check Enable, MM-1-4-3

**Channel Status**

Each compatibility array point will contain one of the characters that follow:

Character	Definition
“.”	Neither the CU or MMU is programmed
C	The CU is programmed, but the MMU is not
M	The MMU is programmed, but the CU is not
x	Both the CU and MMU are programmed

**Color Check Enable, MM-1-4-3**

```

COLOR CHECK ENABLE
ENABLE COLOR CHECK.. X

MMU/LS  1 2 3 4 5 6 7 8 9 0 1 2 3 4 5 6
RED      X X X X X X X X X X X X X X X X
YELLOW   X X X X X X X X X X X X X X X X
GREEN    X X X X X X X X X X X X X X X X
    
```

**Note** • If ENABLE COLOR CHECK is disabled (.), the bottom four lines will not be in view.

Use this screen to do selective color checks on some or all of the 16 MMU channels.

MM-1-4-3 Parameter	Description	Range
ENABLE COLOR CHECK	<p>“.”: Disables all color checks by the controller unit (CU)</p> <p><b>X</b>: Enables the COLOR CHECK DIAGNOSTIC by the CU.</p> <p>The color check feature will verify the CU to MMU by Channel by Color. Any mismatch between the CU and the MMU will cause a CU monitor FLASH.</p> <p>If you selected X next to ENABLE COLOR CHECK, lines for MMU/LS, RED, YELLOW and GREEN will be in view.</p>	<p>“X” Enable all checks</p> <p>“.” Disable all checks</p>

MM-1-4-3 Parameter	Description	Range
RED YELLOW GREEN	<p>If the COLOR CHECK ENABLE Color line is marked “X”:</p> <p><b>X</b>: Enables a CU to MMU Color Check Diagnostic on a by Channel, by Color, per selection.</p> <p>“.”: Disables a CU to MMU Color Check Diagnostic.</p> <p><b>Note</b> • This allows an unused or unusual MMU channel color <i>not</i> to be checked by the CU. This is a redundant check that insures that the indication being commanded by the CU is being sensed by the MMU.</p>	<p>“X” Enable Feature</p> <p>“.” Disable Feature</p>

### Secondary Stations/Tests, MM-1-4-4

SECONDARY TO SECONDARY ADDRESSING									
T&F	01	02	03	04	05	06	07	08	MMU
	.	.	.	.	.	.	.	.	.
D/R	09	10	11	12	13	14	15	16	DIAG
	.	.	.	.	.	.	.	.	.
ENABLE	SDLC	DIAGNOSTIC	TEST	.....NO					

### Enable 3 Critical RFEs Lockup

#### Toggle to select:

- ▶ **NO** to disable the lockup feature that occurs when 3 critical Response Frame Errors (RFEs) occur.
- Or**
- ▶ **YES** to allow such lockups to occur.

### Secondary-to-Secondary Addressing (only on supported devices)

Toggle to enable Secondary-to-Secondary Addressing when the controller is operating in a NEMA TS2 Type 1 or Type 2 cabinet. When Peer-to-Peer communication is enabled, the controller will act as the SDLC gateway for the enabled Secondary-to-Secondary devices. Make sure the device is pre-configured for secondary communication. When a request is present, the controller receives and transmits information from one device to the other.

#### Programming procedure:

- 1** Use Toggle key to enable (X) peer-to-peer communication.
- 2** Use keypad numeric keys to enter a unique address for each device used in the network. Address assignment enables and a zero entry disables device communication. Do *not* enable a device if it is not physically present in the network.

▪ Programmable Communication Ports Submenu, MM-1-5

- 3 **Diagnostic (Test Feature)** – Toggle to enter YES to enable or NO to disable communication with a test fixture that responds to the TS2 defined frame 30. An error is logged, if enabled, when not connected to a test fixture.

MM-1-4-4 Parameter	Description	Range
SECONDARY TO SECONDARY ADDRESSING	Toggle to enable (X) or disable (.) peer-to-peer communications with secondary stations via the RS-485 SDLC link.	X enables . disables
ENABLE SDLC DIAGNOSTIC TEST	An error is logged if enabled, when not connected to a test fixture.	NO disables YES enables

## Programmable Communication Ports Submenu, MM-1-5

```

COMMUNICATIONS SUBMENU

1. ETHERNET

2. PORT 2/C50S

3. PORT 3A/C21S

4. PORT 3B/C22S

5. NTCIP

6. ECPIP
    
```

### Ethernet Port, MM-1-5-1

```

ETHERNET          MAC FF:FF:FF:FF:FF:FF
CONTROLLER IP..... 255.255.255.255
SUBNET MASK..... 255.255.255.255
DEFAULT GATEWAY IP..... 255.255.255.255
SERVER IP ..... 255.255.255.255
LINK SPEED/DUPLEX..... 1000/FULL
DROP-OUT TIME..... 300
    
```

The Ethernet Port can connect 100 Mbps between the controller and external devices.

Ethernet communication supports NTCIP and ECPIP protocols. Settings for these 2 protocols are on MM-1-5-5 and MM-1-5-6 respectively. UDP port for NTCIP is user-configurable on MM-1-5-5. UDP port for ECPIP is fixed at 2101.

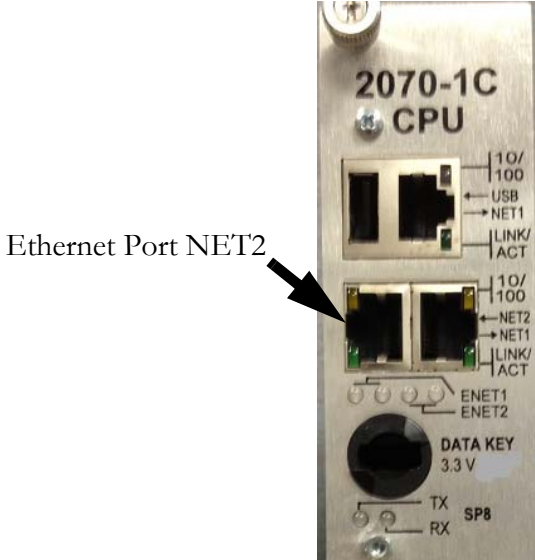

**Note** • Contact your Internet Protocol (IP) specialist to determine the correct setting for each of the parameters defined below.

MM-1-5-1 Parameter	Description	Range
MAC ADDRESS	Display (for info only) of the factory-set controller MAC address.	-
CONTROLLER IP	<p>A unique address used by the Ethernet interface. The format follows the Transmission Control Protocol/Internet Protocol (TCP/IP) standard dot notation. When used, the address must be assigned from the same subnet as the other network devices with which it may communicate, such as a system controller or File Transfer Protocol (FTP) server. If the controller is connected to an IP router, the address must be valid for that router.</p> <p><b>Note</b> • Changing IP address will force transaction mode to make sure the entire IP address is entered before committing. Accepting IP change on each field may cause unintentional IP conflict on the network.</p> <p>On the 2070-1C CPU module, this is to configure the ethernet port NET2.</p> <div style="text-align: center;">  <p>Ethernet Port NET2</p> </div>	0-255
SUBNET MASK	<p>The subnet mask must be the same as the other devices on the IP subnet to which the controller is attached (when an Ethernet interface is being used).</p> <p>On the 2070-1C CPU module, this is to configure the ethernet port NET2, illustrated above.</p>	0-255

## Configuration

- Serial Communication Protocols

MM-1-5-1 Parameter	Description	Range
DEFAULT GATEWAY IP	The default IP address must be that of the Ethernet interface which is on the same subnet as this controller. This gateway address will be used for transmitting IP messages to end systems, which are not on the same subnet as this controller.  On the 2070-1C CPU module, this is to configure the ethernet port NET2, illustrated above.	0-255
SERVER IP	This address is optional, and is only required when the IP-based file download options are to be used. The address must be that of the system where the FTP server resides. This field is only used for local downloads from an FTP server “host” on the local area network.	0-255
LINK SPEED/ DUPLEX	Select the link speed and duplex setting for your Ethernet LAN. Selecting AUTO will cause the link setting to be auto-negotiated or auto-sensed. As of now, only AUTO is allowed on some controller platforms.	AUTO 1000/FULL 1000/HALF 100/FULL 100/HALF 10/FULL 10/HALF
DROP OUT TIME	<b>1-65535:</b> The time from the last valid command before returning to local control.  <b>0:</b> Disables the drop-out feature. This should never be used unless there is an explicit reason.  On the 2070-1C CPU module, this is to configure the ethernet port NET2, illustrated above.	0-65535 seconds

### Serial Communication Protocols

ASC/3 software provides support for numerous serial ports and protocols. Protocols supported are GPS NMEA, Terminal (VT100), NTCIP Level 2, ECPIP, limited AB3418, Metro Rapid and IEEE 1570.

**Note • ASC/3-LX Ver. 32.59.00:**

- Does *not* support communication protocols IEEE1570 and Metro Rapid
- Supports NTCIP on Ethernet, C22S and C21S, but *not* on C50S
- Uses C50S as a Linux Console for diagnostics
- Supports GPS NMEA only on C22S
- Hyperlinks operate, however the black shading (reverse video) in the hyperlink fields is not shown as illustrated in this manual.

**Protocol Selection****GPS NMEA**

Provides a connection to process a GPS NMEA message to set the time and date (or longitude/latitude). The controller supports an Eltec GPS unit and all other standard GPS devices that support a GPS NMEA Protocol message \$GPRMC on serial Ports 2, 3A, C50S or C21S. This feature is compatible with *Centraics* Version 1.5.3 or later. To order a GPS unit (antenna, antenna cable and serial interface cable) from Econolite, use the part numbers listed below:

Part No.	Connector	Name	For Controllers
TSD25-GPS	25 Pins for Port 2	Eltec GPS DB25 Serial Time Sync Unit	<i>ASC/3, ASC/3-RM</i>
TSD9-GPS	9 Pins for Ports 3A, C50S, C21S	Eltec GPS DB9 Serial Time Sync Unit	<i>ASC/3, ASC/3-RM, 2070</i>

Set the parameters in MM-1-5-2 or MM-1-5-3 as shown in the sample screens for GPS NMEA in *Port 2/C50S, MM-1-5-2* on page 6-34 and *Port 3A/C21S, MM-1-5-3* on page 6-35.

**Terminal**

Provides VT100-compatible communication.

**NTCIP**

Provides NTCIP-compatible communication.

**ECPIP**

Provides ECPIP-compatible communication. This protocol is tailored to function in an Econolite Aries or Zone Master system.

**AB3418**

Provides AB3418-compatible communication. This protocol is tailored to comply with the California AB3418 specification.

- Port 2/C50S, MM-1-5-2

**Metro Rapid**

Provides a Metro Rapid and Pilot Protocol Bus-to-Signal Priority compatible communication between computers and modems. This protocol was developed to comply with the County of Los Angeles Metro Rapid specification.

**IEEE 1570**

Provides a limited IEEE 1570 interface compatible communication between wayside devices and modems. These are specific applications that use IEEE 1570.

Port 2/C50S, MM-1-5-2

These ports provide for the EIA-232 terminal communications.

**Note •**

- In the screens below, the different Protocols are shown in **bold**.
- Some of the options on ASC/3 may not be available in ASC/3-2070 or ASC/3-LX.
- To make data entries in these displays, refer to *Serial Port Parameters* on page 6-38.

MM-1-5-2 — Port 2 on ASC/3	MM-1-5-2 — Port C50S on 2070
COMM PORT 2 ENABLE..... NO PROTOCOL <b>GPS NMEA</b> BIT RATE.... 9600 D/P/S..... 8/N/1 DUPLEX..... FULL FLOW CONTROL... YES	COMM PORT C50S ENABLE..... YES PROTOCOL <b>GPS NMEA</b> BIT RATE.... 9600 D/P/S..... 8/N/1 DUPLEX..... FULL
COMM PORT 2 ENABLE..... YES PROTOCOL <b>TERM</b> BIT RATE.... 9600 D/P/S..... 8/N/1 DUPLEX..... HALF FLOW CONTROL... YES	COMM PORT C50S ENABLE..... YES PROTOCOL <b>TERM</b> BIT RATE.... 38400 D/P/S..... 8/N/1 DUPLEX..... HALF
COMM PORT 2 ENABLE..... YES PROTOCOL <b>NTCIP</b> BIT RATE.... 9600 ADDRESS..... 65535 D/P/S..... 8/N/1 GROUP ADDRESS. 65535 DUPLEX..... HALF SINGLE FLAGGED.. YES FLOW CONTROL... YES DROP-OUT TIME. 65535	COMM PORT C50S ENABLE..... YES PROTOCOL <b>NTCIP</b> BIT RATE.... 38400 ADDRESS..... 65535 D/P/S..... 8/N/1 GROUP ADDRESS. 65535 DUPLEX..... HALF DROP-OUT TIME. 65535
INTERSECTION MONITOR MODEM SETUP STRING..... USER USER STRING:	

MM-1-5-2 — Port 2 on ASC/3	MM-1-5-2 — Port C50S on 2070
<pre> COMM PORT 2 ENABLE..... YES PROTOCOL      <b>ECPIP</b> BIT RATE.... 9600 TRD (ms)..... 0.0 D/P/S..... 8/N/1 DROP-OUT TIME. 65535 DUPLEX..... HALF FLOW CONTROL... YES                     </pre>	<p><b>Note:</b> ECPIP is not supported on Port C50S.</p>
<pre> COMM PORT 2 ENABLE..... YES PROTOCOL      <b>AB3418</b> BIT RATE.... 9600 ADDRESS..... 65535 D/P/S..... 8/N/1 GROUP ADDRESS. 65535 DUPLEX..... HALF SINGLE FLAGGED.. YES FLOW CONTROL... YES DROP-OUT TIME. 65535                     </pre>	<pre> COMM PORT C50S ENABLE..... YES PROTOCOL      <b>AB3418</b> BIT RATE.... 38400 ADDRESS..... 65535 D/P/S..... 8/N/1 GROUP ADDRESS. 65535 DUPLEX..... HALF DROP-OUT TIME. 65535                     </pre>
<pre> COMM PORT 2 ENABLE..... YES PROTOCOL <b>METRO RAPID</b> BIT RATE.... 9600 D/P/S..... 8/N/1 DUPLEX..... HALF FLOW CONTROL... YES                     </pre>	
<pre> COMM PORT 2 ENABLE..... YES PROTOCOL <b>IEEE 1570</b> BIT RATE.... 9600 ATCS RAILROAD... 0 D/P/S..... 8/N/1 ATCS RR LINE.... 0 DUPLEX..... HALF ATCS GROUP..... 0 FLOW CONTROL... YES           WAYSIDE ATC                                DEVICE      0      0                                SUBNODE    0      0                     </pre>	

### Port 3A/C21S, MM-1-5-3

These ports provide for the EIA-232 terminal communications.

For *ASC/3* hardware, port 3A provides for EIA-232 serial communications through the NEMA-defined Port 3 connector (reference NEMA TS2 3.3.3). This adapts the controller to operate in place of an *ASC/2* equipped with an RS 232 telemetry module.

▪ Port 3B/C22S, MM-1-5-4

**Note** •

- In the screens below, the different Protocols are shown in **bold**.
- Some of the options on ASC/3 may not be available in ASC/3-2070 or ASC/3-LX.
- To make data entries in these displays, refer to *Serial Port Parameters* on page 6-38.

MM-1-5-3 – Port 3A on ASC/3	MM-1-5-3 – Port C21S on 2070
COMM PORT 3A ENABLE..... NO PROTOCOL <b>GPS NMEA</b> BIT RATE.... 9600 D/P/S..... 8/N/1 DUPLEX..... FULL FLOW CONTROL... YES	COMM PORT C21S ENABLE..... YES PROTOCOL <b>GPS NMEA</b> BIT RATE.... 9600 D/P/S..... 8/N/1 DUPLEX..... FULL
COMM PORT 3A ENABLE..... YES PROTOCOL..... <b>TERM</b> BIT RATE.... 9600 D/P/S..... 8/N/1 DUPLEX..... HALF FLOW CONTROL... YES	COMM PORT C21S ENABLE..... YES PROTOCOL..... <b>TERM</b> BIT RATE.... 9600 D/P/S..... 8/N/1 DUPLEX..... HALF FLOW CONTROL... YES
COMM PORT 3A ENABLE..... YES PROTOCOL..... <b>NTCIP</b> BIT RATE.... 9600 ADDRESS..... 65535 D/P/S..... 8/N/1 GROUP ADDRESS. 65535 DUPLEX..... HALF SINGLE FLAGGED.. YES FLOW CONTROL... YES DROP-OUT TIME. 65535	COMM PORT C21S ENABLE..... YES PROTOCOL..... <b>NTCIP</b> BIT RATE.... 9600 ADDRESS..... 65535 D/P/S..... 8/N/1 GROUP ADDRESS. 65535 DUPLEX..... HALF DROP-OUT TIME. 65535 FLOW CONTROL... YES
COMM PORT 3A ENABLE..... YES PROTOCOL..... <b>ECPIP</b> BIT RATE.... 9600 TRD (ms)..... 0.0 D/P/S..... 8/N/1 DROP-OUT TIME. 65535 DUPLEX..... HALF FLOW CONTROL... YES	COMM PORT C21S ENABLE..... YES PROTOCOL..... <b>ECPIP</b> BIT RATE.... 9600 TRD (ms)..... 0.0 D/P/S..... 8/N/1 DROP-OUT TIME. 65535 DUPLEX..... HALF FLOW CONTROL... YES
COMM PORT 3A ENABLE..... YES PROTOCOL..... <b>AB3418</b> BIT RATE.... 9600 ADDRESS..... 65535 D/P/S..... 8/N/1 GROUP ADDRESS. 65535 DUPLEX..... HALF SINGLE FLAGGED.. YES FLOW CONTROL... YES DROP-OUT TIME. 65535	COMM PORT C21S ENABLE..... YES PROTOCOL..... <b>AB3418</b> BIT RATE.... 9600 ADDRESS..... 65535 D/P/S..... 8/N/1 GROUP ADDRESS. 65535 DUPLEX..... HALF DROP-OUT TIME. 65535 FLOW CONTROL... YES

Port 3B/C22S, MM-1-5-4

These ports provide for the EIA-232 terminal communications.

For ASC/3 hardware, port 3B provides for FSK communications through NEMA defined Port 3 connections (reference NEMA TS2 3.3.3) or an ASC/2 defined 25-pin Telemetry connector. These options allow the controller to be compatible with NEMA TS2 and replace an ASC-8000 or ASC/2 family controller.

**Note**

- In the screens below, the different Protocols are shown in **bold**.
- Some of the options on ASC/3 may not be available in ASC/3-2070 or ASC/3-LX.
- To make data entries in these displays, refer to *Serial Port Parameters* on page 6-38.

MM-1-5-4 — Port 3B on ASC/3	MM-1-5-4 — Port C22S on 2070
COMM PORT 3B ENABLE..... YES PROTOCOL..... <b>NTCIP</b> BIT RATE.... 115200 ADDRESS..... 65535 D/P/S..... 8/N/1 GROUP ADDRESS. 65535 DUPLEX..... HALF SINGLE FLAGGED.. YES FLOW CONTROL... YES DROP-OUT TIME. 65535 RTS-CTS DELAY. 6810 RTS TURN OFF.. 6810 EARLY RTS..... YES	COMM PORT C22S ENABLE..... YES PROTOCOL..... <b>NTCIP</b> BIT RATE.... 115200 ADDRESS..... 65535 D/P/S..... 8/N/1 GROUP ADDRESS. 65535 DUPLEX..... HALF DROP-OUT TIME. 65535 FLOW CONTROL... YES
COMM PORT 3B ENABLE..... YES PROTOCOL..... <b>ECPIP</b> BIT RATE.... 115200 TRD (ms)..... 0.0 D/P/S..... 8/N/1 DROP-OUT TIME. 65535 DUPLEX..... HALF FLOW CONTROL... YES RTS-CTS DELAY. 6810 RTS TURN OFF.. 6810 EARLY RTS..... YES FSK HARDWARE... YES	
COMM PORT 3B ENABLE..... YES PROTOCOL..... <b>TERM</b> BIT RATE.... 115200 D/P/S..... 8/N/1 DUPLEX..... HALF FLOW CONTROL... YES RTS-CTS DELAY. 6810 RTS TURN OFF.. 6810 EARLY RTS..... YES	COMM PORT C22S ENABLE..... YES PROTOCOL..... <b>TERM</b> BIT RATE.... 115200 D/P/S..... 8/N/1 DUPLEX..... HALF FLOW CONTROL... YES
COMM PORT 3B ENABLE..... RS232 PROTOCOL..... <b>AB3418</b> BIT RATE.... 115200 ADDRESS..... 65535 D/P/S..... 8/N/1 GROUP ADDRESS. 65535 DUPLEX..... HALF SINGLE FLAGGED.. YES FLOW CONTROL... YES DROP-OUT TIME. 65535 RTS-CTS DELAY. 6810 RTS TURN OFF.. 6810 EARLY RTS..... YES	COMM PORT C22S ENABLE..... YES PROTOCOL..... <b>AB3418</b> BIT RATE.... 115200 ADDRESS..... 65535 D/P/S..... 8/N/1 GROUP ADDRESS. 65535 DUPLEX..... HALF DROP-OUT TIME. 65535 FLOW CONTROL... YES





MM-1-5-2, 3, 4 Parameter	Description	Range
DUPLEX HALF OR FULL	<p><b>IMPORTANT</b> • Please consult with the factory before changing this setting.</p> <p>As required by modem specifications, the port may be configured as Half or Full Duplex. Toggle to select HALF or FULL.</p> <p><b>HALF</b> duplex can receive data only after transmission of a response is complete.</p> <p><b>FULL</b> duplex can receive and transmit data at the same time.</p> <p>Port 3B supports FSK module that may have a physical switch that arbitrates Half or Full duplex for port 3B.</p>	HALF/FULL
FLOW CONTROL	<p>Modem control signals sent over serial ports:</p> <ul style="list-style-type: none"> <li>Carrier Detect (CD)</li> <li>Data Set Ready (DSR)</li> <li>Data Terminal Ready (DTR)</li> </ul> <p>Set this to NO when using devices that do not support modem control signals, such as fiber modems.</p>	YES enables NO disables
PROTOCOL	<p><b>Ports 2, 3A, 3B:</b> Toggle to select TERM, NTCIP, ECPIP, AB3418</p> <p><b>Port 2:</b> Toggle to select METRO RAPID, IEEE 1570</p> <p><b>Port 2 and Port 3A:</b> Toggle to select GPS NMEA</p> <p><b>Note</b> • Regardless of the protocol selected, if a modem is going to be connected, a null-modem adaptor or cable may be required.</p> <p><b>For ASC/3-2070 or ASC/3-LX:</b></p> <ul style="list-style-type: none"> <li><b>Ports C50S, C21S, C22S:</b> Toggle to select NTCIP, AB3418, ECPIP, TERM</li> <li><b>Ports C21S and C22S:</b> Toggle to select IEEE 1570 and GPS NMEA</li> <li><b>Port C21S:</b> Toggle to select ECPIP</li> </ul>	TERM, NTCIP, ECPIP, AB3418, METRO RAPID, IEEE 1570, GPS NMEA

▪ Serial Port Parameters

MM-1-5-2, 3, 4 Parameter	Description	Range
ADDRESS	<p>Use numeric keys (0-9) to specify a unique address number (1-65535) to which this port will respond. Zero (0) disables responding to any address.</p> <p>NTCIP/AB3418 protocol</p> <p>1-65535: Address to respond to.</p> <p>0: Disables responses.</p> <p>ECPIP protocol</p> <p>1-24: Address to respond to.</p> <p>0 &amp; 25-65535: Disables responses.</p> <p>Metro Rapid protocol</p> <p>1-8191: Address to respond to.</p> <p>0 &amp; 8192-65535: Disables responses.</p>	1-65535 address 0 disables
GROUP ADDRESS	<p>Use the numeric keys (0-9) to specify an address number that allows a master station to access this slave station via group command of NTCIP protocol.</p> <p>1-62 and 64-65535 for AB3418.</p> <p>1-62 for NTCIP.</p> <p>Address 63 is reserved as an “all stations” group address.</p> <p>Address zero (0) excludes the station from any group.</p>	0-65535 except 63
SINGLE FLAGGED	<p><b>For AB3418 or NTCIP.</b></p> <p>Toggle to select YES (enable) or NO (disable).</p> <p><b>YES:</b> The frame flag is used as both the closing flag for one frame and the opening flag for the next frame.</p> <p><b>NO:</b> Each response frame contains an opening and a closing flag.</p>	YES, NO
DROP-OUT TIME	<p>Use the numeric keys (0-9) to enter the time in seconds (1-65535) from when the last valid command occurs before the controller is returned to local control. Zero (0) disables the dropout feature.</p>	1-65535 seconds 0 disables
MODEM SETUP STRING	<p>Toggle to select one of the internal modem setup string options (NONE, 56K, or USER). Use this typically for the optional Intersection Monitor module.</p>	NONE, 56K, USER

MM-1-5-2, 3, 4 Parameter	Description	Range
USER STRING	<p>Specifies the unique modem setup string required for the modem being used. This string is only used if the MODEM SETUP STRING is set to USER.</p> <p>The keypad is in alphanumeric data entry mode when in this field. Consult the manual for your modem to determine the setup string required. Use this typically for the optional Intersection Monitor module.</p>	0-9, A-Z, Enter these other characters with key <b>1</b> : space \$/>#*;\!"@&.? =-
TRD TELEMETRY RESPONSE DELAY	<p><b>ECPIP Only</b></p> <p>Telemetry Response Delay (TRD) compensates response timing for overall communication delays. Decrease (start communication earlier) to compensate for longer delays and increase (start communication later) to compensate for shorter delays.</p>	0.0-25.5 msec
RTS TO CTS DELAY	<p><b>Applicable to Port 3B FSK Only</b></p> <p>Use numeric keys (0-9) to specify the amount of delay (in milliseconds) between Request To Send (RTS) and Clear To Send (CTS). (0-9) to specify the amount of delay (in milliseconds) between RTS and CTS. Delay between the RTS and CTS is required by some communication devices. This period of time after RTS is applied prior to sending data for transmission. RTS is turned on and timing begins at the end of the telemetry response delay or a response is ready for transmission, whichever is greater.</p>	0-381 milliseconds

▪ NTCIP Parameters, MM-1-5-5

MM-1-5-2, 3, 4 Parameter	Description	Range
RTS TURN OFF DELAY	<p><b>Applicable to Port 3B FSK Only</b></p> <p>Use numeric keys (0-9) to specify the amount of delay (in milliseconds) between Request To Send (RTS) and Clear To Send (CTS). (0-9) to specify the amount of delay (in milliseconds) between RTS and CTS. Delay between the RTS and CTS is required by some communication devices. This period of time after RTS is applied prior to sending data for transmission. RTS is turned on and timing begins at the end of the telemetry response delay or a response is ready for transmission, whichever is greater.</p>	0-681 milliseconds
EARLY RTS	<p><b>Applicable to Port 3B FSK Only</b></p> <p>Toggle to enable (YES) or disable (NO) the Early RTS function.</p> <p><b>YES:</b> RTS is turned on when the telemetry response delay begins. This minimizes overall response time, if Telemetry Response Delay is not zero, by using that delay time as part of the RTS to CTS delay. RTS is not turned on early if Telemetry Response Delay is zero.</p> <p><b>NO:</b> RTS is off during timing of Telemetry Response Delay. This can be a minimum turnaround delay for half-duplex operation.</p>	YES enable NO prevent

NTCIP Parameters, MM-1-5-5

```

NTCIP
BACKUP TIME..... 65535
UDP PORT..... 65535
ETHERNET PRIORITY..... 1
PORT C50S PRIORITY..... 4
PORT C21S PRIORITY..... 2
PORT C22S PRIORITY..... 3
    
```

The example screen, above, is for a 2070 screen.

Port parameters define the NTCIP backup time, UDP Port and priority of the port communications. This programming is only required when the controller is communicating through one of its ports.

From this screen, you specify the NTCIP Backup Time parameters and Ports 2/C50S, 3A/C21S, 3B/C22S, and Ethernet Priority values.

MM-1-5-5 Parameter	Description	Range
NTCIP BACKUP TIME	<p>Use numeric keys (0-9) to enter the appropriate NTCIP Backup Time value in seconds. Value entered (1-65535) establishes the time that the parameters are under control of the “SET” command and will remain if no “SET” command is received by the controller.</p> <p>Value 0 disables clearing of the parameters that were set regardless of the time between “SET” commands.</p>	<p>0 disables</p> <p>1-65535 sets time</p>
UDP PORT	<p>STMP or IP over PMPP using SNMP or STMP Frame should use this port setting.</p> <p>For <i>ASC/3-2070</i> or <i>ASC/3-LX</i>, you can set port 161 to support applications that have a fixed SNMP port setting.</p>	<p>161,</p> <p>500-65535</p>
PORTS 2/C50S, 3A/C21S, 3B/C22S, and ETHERNET PRIORITY	<p>Use numeric keys (0-9) to enter appropriate priority level value (1-4, with 1 highest) for the port. Value selects the priority of commands from that port. While a higher priority port is in control, the lower priority port can continue to retrieve status information. The order of priority when two or more have the same priority number is (from highest to lowest) Ethernet, Port 2/C50S, Port 3A/C21S, then Port 3B/C22S.</p>	<p>1-4, with 1 highest</p>

- ECPIP Parameters, MM-1-5-6

### ECPIP Parameters, MM-1-5-6

```

ECPIP          FRI 02/10/2012|08:22:32
CONTROLLER ADDRESS.....0
EXPANDED SYSTEM DETECTOR ADDRESS.....0

SYSTEM DETECTOR ASSIGNMENT:
SYSTEM DET  1  2  3  4  5  6  7  8
LOCAL DET   64 64 64 64 64 64 64 64
SYSTEM DET  9 10 11 12 13 14 15 16
LOCAL DET   64 64 64 64 64 64 64 64
    
```

MM-1-5-6 Parameter	Description	Range
CONTROLLER ADDRESS	<p><b>ECPIP Protocol</b></p> <p><b>1-24</b> programs the address to which this port will respond.</p> <p><b>0</b> disables communication responses.</p> <p><b>Note • There is only 1 ECPIP address setting.</b></p>	ECPIP 1-24 address 0 disables
EXPANDED SYSTEM DETECTOR ADDRESS	<p>Use numeric keys (0-9) to specify a unique address (1-24) to allow the Zone Master to access system detectors 9-16.</p> <p><b>1-24:</b> Allows access by the Zone Master (when PROTOCOL set to ECPIP) to system detectors 9-16. This address must be one of the 24 addresses available on the Zone Master system.</p> <p><b>0 (zero):</b> Disables access to system detectors 9-16.</p> <p><b>Note • System detectors 1-8 do NOT require an address separate from that of the controller.</b></p>	0 Disable 1-24 Enable
LOCAL DET	<p><b>Local System Detector</b></p> <p>Cursor to a Local System Detector, 1 thru 16.</p> <p>Assign Vehicle Detector (1-64) or disable (0) that Local System Detector.</p> <p><b>Note • Detectors assigned to a phase may also be assigned as local system detector for reporting to a Zone Master or Aries system.</b></p>	0 Disable 1-64 Enable

## Enable Logging Submenu, MM-1-6

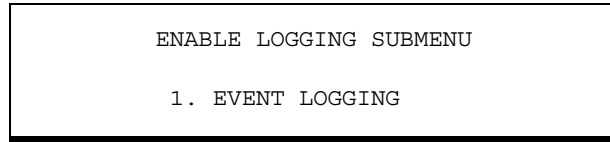

### Event Logging, MM-1-6-1

This menu permits you to selectively enable and disable the real time logging of ASC/3 events. The event buffer can store 500 non-detector error events and 300 detector error events. When full, the oldest events are discarded to make room for the new.

#### To program Event Logging:

- Use Toggle, **0/YES**, to select either YES or NO for each of the options (including the scroll area) provided on the Event Logging data entry (MM-1-6-1).

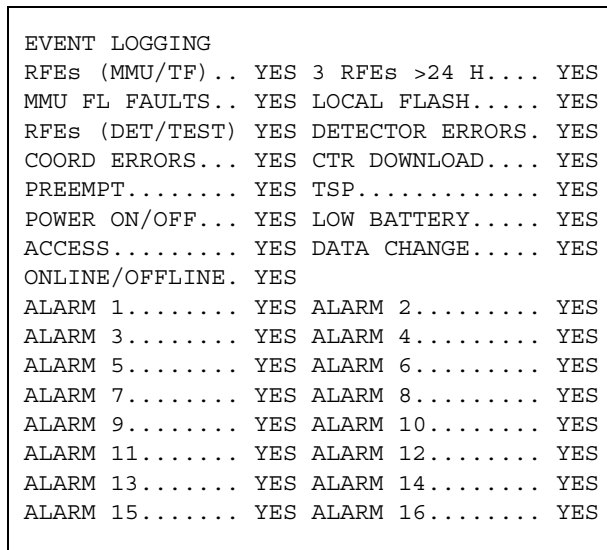

MM-1-6-1 Parameter	Description	Range
CRITICAL RFEs (MMU/TF)	Enables logging SDLC Response Frame Errors (RFEs) that result in the controller flash. These RFEs, related to the MMU and/or Terminals & Facilities (TF), are considered critical and will put the intersection into flash when there are six or more RFEs in the last ten tries. This logging mode applies to TS2 operation only.	YES enables NO disables
3 CRITICAL RFE ERRORS IN 24 HOURS	Enables logging of the latched controller flash caused by 3 of the same critical RFEs (MMU/TF) in the last 24-hour period. This logging mode applies to TS2 operation only.	YES enables NO disables

Configuration

▪ Event Logging, MM-1-6-1

MM-1-6-1 Parameter	Description	Range
MMU FLASH FAULTS	Enables logging of flash events reported via SDLC from the MMU or detected by the controller. This logging mode applies to TS2 operation only.	YES enables NO disables
LOCAL FLASH	<p>Enables logging of local flash events:</p> <p>CYCLE FAULT: A serviceable call has not been serviced for two controller cycles.</p> <p><b>Note</b> • <b>A controller cycle is the time the controller would take to time all phases if max recall was applied to all phases.</b></p> <p>CABINET FLASH caused by input, TIME BASE action plan, coordination pattern, manual selection, or system command.</p> <p>This logging mode applies to TS1 and TS2 operation.</p>	YES enables NO disables
NON-CRITICAL RFEs (DET/TEST)	Enables logging of the non-critical SDLC response frame errors (RFEs) when there are six or more in the last ten tries related to detector (DET) BIUs and the TEST fixture. These RFEs are considered non-critical and will not put the intersection into flash. Applies only if the DET BIUs and/or TEST fixture are enabled (Reference MM-1-4-1). This logging mode applies to TS2 operation only.	YES enables NO disables
DETECTOR ERRORS	<p>Enables logging of detector errors reported by:</p> <p>Valid SDLC response frames including watchdog failure, open loop, shorted loop, and excessive inductance change.</p> <p>Controller detected errors reported under TS1, TS2 operations that include no activity, max presence, and erratic counts.</p>	YES enables NO disables
COORDINATION ERRORS	<p>Enables logging of:</p> <p><b>COORD ACTIVE:</b> No fault or conflict.</p> <p><b>COORD FAULT:</b> A cycle fault is in effect and a serviceable call has not been serviced within two cycles.</p> <p><b>COORD LOCAL FREE:</b> Controller taken out of coordination by a command or input.</p> <p><b>COORD PROGRAM FREE:</b> Controller taken out of coordination by the TIME BASE program.</p> <p><b>COORD DATA ERRORS:</b> Incorrect programming data. The coordinator cannot run.</p>	YES enables NO disables



MM-1-6-1 Parameter	Description	Range
CONTROLLER DOWNLOAD	Enables the logging of controller download events. An event will be logged when the controller starts responding to download commands. This logging mode applies to TS1 and TS2 operation.	YES enables NO disables
PREEMPT	Enables logging of preemption events. Log indicates when priority preemptors are active. Records occurrence date, time, and preemptor number. This logging mode applies to TS1 and TS2 operation.	YES enables NO disables
TSP	<p>This is an ECPI feature whose logging mode applies to TS1 and TS2 operation.</p> <p>Enables logging of 4 possible TSP events:</p> <ul style="list-style-type: none"> <li>■ TSP Call Received</li> <li>■ TSP Inhibited Call Received</li> <li>■ TSP Cycle Activated</li> <li>■ TSP Cycle Terminated</li> </ul> <p><b>Note</b> • You can see the TSP events on Screen MM-8-6-1-1.</p>	YES enables NO disables
POWER ON/OFF	Enables logging of power ON and power OFF events. Reports when power on and off occur. This logging mode applies to TS1 and TS2 operation.	YES enables NO disables
LOW BATTERY	Enables logging of low voltage conditions of the battery used to hold up the CMOS RAM that stores run-time data. A battery in good condition can hold up the RAM in excess of 30 days. This logging mode applies to TS1 and TS2 operation.	YES enables NO disables
ACCESS	Enables the log to record the access code and when an access was granted to the controller. This logging mode applies to TS1 and TS2 operation.	YES enables NO disables
DATA CHANGE	Enables the log to record when there is a data change by the keypad. Only the first data change event is logged after access is granted. All further data change events are not logged until a new user logs in or the display has timed out (20 minutes). This logging mode applies to TS1 and TS2 operation.	YES enables NO disables

## Configuration

---

- *Event Logging, MM-1-6-1*

<b>MM-1-6-1 Parameter</b>	<b>Description</b>	<b>Range</b>
ONLINE/OFFLINE	<b>Online/Offline Events</b> Enables logging of the Online and Offline Events. These typically occur before and after preempt, flash and power-up.	YES enables NO disables
LOG ALARM EVENTS	Enables logging of all ALARM 1-16 EVENTS. Each alarm can be individually enabled or disabled by positioning the cursor on the line to be changed, then pressing Toggle, <b>O/YES</b> , to display either YES or NO. This logging mode applies to TS1 and TS2 operation.	YES enables NO disables

## Display/Access Submenu, MM-1-7

```

DISPLAY/ACCESS SUBMENU

1. ADMINISTRATION

2. DISPLAY OPTIONS

3. SECURITY ACCESS
    
```

### Administration, MM-1-7-1

```

ADMINISTRATION

ENABLE CU/CABINET INTERLOCK CRC.... NO
CU/CABINET INTERLOCK CRC VALUE..... 0000
CU/CABINET INTERLOCK HW VALUE..... 0000

REQUEST DOWNLOAD CONTROLLER DATA... NO
CONTROLLER DATABASE CRC ..... A650
ENABLE AUTOMATIC BACKUP TO DATAKEY. NO
    
```

MM-1-7-1 Parameter	Description	Range
ENABLE CU/CABINET INTERLOCK CRC	<p><b>YES:</b> Enables checking of the database 16-bit CRC and the CRC wired in the cabinet to the controller inputs. When there is a discrepancy, the controller will go to flash.</p> <p><b>IMPORTANT</b> • The 16-bit CRC input must match the database CRC. With this option enabled, there is NO data entry or download.</p> <p><b>NO:</b> Disables the CRC check and allows for data entry and download.</p> <p><b>Note</b> • When this option is used, the cabinet must be wired to reflect any change to the ASC/3 database before the controller is put in service.</p>	YES enables NO disables

MM-1-7-1 Parameter	Description	Range
CU/CABINET INTERLOCK CRC VALUE  and  CU/CABINET INTERLOCK HW VALUE	This feature, when enabled, requires a CRC match between certain database variables (the computed CRC) and a CRC wired to 16 controller inputs (the hardwired CRC).  If a CRC mismatch is detected at power ON, the controller will remain in CVM flash. If a CRC mismatch occurs while the controller is running, it will proceed to automatic flash with CVM TRUE.  CRC is checked for the database sections that follow:  MM-1-1-1 Ring Sequence  MM-1-1-2 Phase Compatibility  MM-2-2 Vehicle Overlaps  MM-2-3 Pedestrian Overlaps  MM-4-1 Preemptor 1-10  MM-4-2 Low Priority Preemptors	0 to 0xffff
REQUEST DOWNLOAD OF CONTROLLER DATA	<b>YES</b> requests the download of this controller’s database from the Traffic Operations Center. This entry is temporary and not part of the database. It automatically sets to <b>NO</b> when the download is complete or access is logged off.	YES enables  NO disables
CONTROLLER DATABASE CRC	This CRC is computed over the entire ASC/3 Database.	0 to 0xffff
ENABLE AUTOMATIC BACKUP TO DATAKEY	<b>YES:</b> Enables the controller to backup database changes to the Datakey 20 minutes after the change has occurred.  <b>NO:</b> Disables this function.	YES enables  NO disables

**CU/CABINET INTERLOCK CRC application procedure:**

- 1 Map all designated CU/CABINET INTERLOCK CRC Input signals in the cabinet.  
  
 Enabled Remote flash – Tied to Logic Ground. This is to signify that CU/CABINET INTERLOCK CRC is enabled in the cabinet. Auto Flash input is inverted in this operation so that any non CRC enabled controller will have a true flash command.
- 2 Complete the programming of the Database to make sure valid CU/CABINET INTERLOCK CRC is completed and final.
- 3 Enable CU/CABINET INTERLOCK CRC Option (MM-1-7-1).

- 4 Check for the computed CRC value (CU/CABINET INTERLOCK CRC VALUE). Make sure the bits that have 1 value are grounded.
- 5 Turn ON the controller/Cabinet.

### CU/CABINET INTERLOCK CRC example

Assuming the designated signals are the following (Typical TS1 IDOT cabinet):

CRC Bit Designation	Input Signal
00	INHIBIT MAX TERM (Ring 1)
01	IND. LAMP CONTROL
02	WAS FORCE OFF (Ring 1)
03	OMIT RED CLEAR (Ring 1)
04	RED REST (Ring 1)
05	CALL NON-ACT II
06	WALK REST MODIFIER
07	PED RECYCLE (Ring 1)
08	MAX 2 SELECTION (Ring 1)
09	PED RECYCLE (Ring 2)
10	MAX 2 SELECTION (Ring 2)
11	FORCE OFF (Ring 2)
12	INHIBIT MAX TERM (Ring 2)
13	TEST B
14	RED REST (Ring 2)
15	OMIT RED CLEAR (Ring 2)

**Configuration**

- Administration, MM-1-7-1

Computed CU/CABINET INTERLOCK CRC Value is 51DD as seen from MM-1-7-1:

Interlock CRC in Hex	5				1				D				D			
Bit #	15	14	13	12	11	10	9	8	7	6	5	4	3	2	1	0
CRC (Binary)	0	1	0	1	0	0	0	1	1	1	0	1	1	1	0	1
Grounded Inputs		14		12				8	7	6		4	3	2		0

ON Bits	Tie these Input Signals to Logic Ground
N/A	REMOTE FLASH Input
14	RED REST ( 2 )
12	INHIBIT MAX TERM ( 2 )
8	MAX 2 SELECTION ( 1 )
7	PED RECYCLE ( 1 )
6	WALK REST MODIFIER
4	RED REST ( 1 )
3	OMIT RED CLEAR ( 1 )
2	FORCE OFF ( 1 )
0	INHIBIT MAX TERM ( 1 )

### Display Options, MM-1-7-2

```

DISPLAY OPTIONS

KEY CLICK ENABLE..... YES

BACKLIGHT ENABLE..... YES

LED MODE..... AUTO

MAIN STATUS DISPLAY MODE... ADVANCED

SCREEN FORMAT.....ADVANCED
    
```

MM-1-7-2 Parameter	Description	Range
KEY CLICK ENABLE	<b>YES:</b> Enables a beep sound feedback (in addition to the tactile feedback) when you press a front panel key. <b>NO:</b> Selects silent operation.	YES enables NO disables
BACKLIGHT ENABLE	<b>YES:</b> Turns ON the LCD backlight whenever you press a front-panel key. The backlight turns OFF automatically after 30 minutes of keypad inactivity. <b>NO:</b> Disables the backlight.	YES enables NO disables
LED MODE	<b>AUTO:</b> The software automatically selects what mode to display based on hardware capability: <i>ASC/3-2100, 1000, RM:</i> Tri-Color (Yellow, Green, and Red) <i>2070:</i> Same as SINGLE COLOR <b>SINGLE COLOR (Red):</b> You can set the controller to stay in this mode. <b>ALT MODE 1:</b> Reserved <b>ALT MODE 2:</b> Reserved  For a list of the LED conditions for Tri-Color and Single-Color modes, refer to <i>Front Panel LED Indicator</i> on page 14-1.	AUTO, SINGLE COLOR, ALT MODE 1, ALT MODE 2

- Display Options, MM-1-7-2

MM-1-7-2 Parameter	Description	Range
MAIN STATUS DISPLAY MODE	<p><b>Main Status Display Mode</b></p> <p>Use this field to change the default Main Status Display option. To switch between display modes, press <b>NEXT SCREEN</b>.</p> <p>Basic and Advanced Main Status Displays are explained and shown in <i>Main Status Displays</i> on page 12-2.</p>	ADVANCED, BASIC
SCREEN FORMAT	<p><b>Format for the Controller Screens</b></p> <p><b>ADVANCED:</b> Normal screens for <i>ASC/3</i>. This is the default.</p> <p><b>BASIC:</b> Each menu selection first shows the fields for basic operation. Other fields for advanced operation are also present but, to access them, you must scroll down beyond the bottom of the first screen.</p> <p><b>Note</b> • <b>After you change this setting, to enable it you must power cycle the controller.</b></p>	ADVANCED, BASIC



### Security Access, MM-1-7-3

To activate Front Panel Access Security, change the User Account 1 (Administrator) Access Code to a non- zero number. To do this, refer to the instructions below for MM-1-7-3.

When security is enabled, if you press a menu key, the screen shown below will come into view:

```
*****
*           ACCESS CODE: [XXXXXXXX]           *
*FOR READ-ONLY ACCESS PRESS [ENTER] KEY*
*****
```

To gain access privilege, enter the valid Access Code. If you do *not* know an Access Code, to gain READ-ONLY privilege, press **ENTER**. To change the Access Code or to log off, press **SPEC FUNC** then press **STATUS DISPLAY** (for 2070, press \* then press **E**).

You can access MM-1-7-3 (shown below):

- If security has *not* been activated.
- If security has been activated, with the access code that has the ALL Access for the security privilege.

SECURITY ACCESS -SELECT NAME-		v
01 administrator--	02 L TA-----	▬
03 M WILLIAMS-----	04 D PADDOCK-----	
05 M ALLWOOD-----	06 J GARCIA-----	
07 R DUNMYER-----	08 K YANG-----	
09 J FORBES-----	10 P HOLLINGSWORTH	
11 -----	12 -----	
13 -----	14 -----	
15 -----	16 -----	
17 -----	18 -----	
19 -----	20 -----	
21 -----	22 -----	
23 -----	24 -----	
25 -----	26 -----	
27 -----	28 -----	
29 -----	30 -----	
31 -----	32 -----	
33 -----	34 -----	
35 -----	36 -----	
37 -----	38 -----	
39 -----	40 -----	
41 -----	42 -----	
43 -----	44 -----	
45 -----	46 -----	
47 -----	48 -----	
49 -----	50 -----	

The Security Access feature has security access for up to 50 users. There are different levels of security privilege to which each user can be programmed.

- Security Access, MM-1-7-3

**To edit User Account information:**

- 1** In MM-1-7-3, use arrow keys to move the cursor to the desired User Account.
- 2** Press **ENTER**..

The display below comes into view.

```

USER ACCOUNT 2

                CURRENT          CHANGE
NAME            L TA            L TA
ACCESS          READ-ONLY       READ-WRITE
ACCESS CODE     *****          0
                ACCESS CODE CONFIRM 0

  1   2   3   4   5   6   7   8   9
SPACE ABC DEF GHI JKL MNO PQRS TUV WXYZ
    
```

Use this display to change user information. Make entries in this display as shown in the table below. Except for ACCESS CODE, which requires confirmation, all entry fields take effect immediately after you move the cursor or press **ENTER**.

- After you make changes, to *keep* the changes in permanent memory, wait a minimum of 10 seconds before you cycle power to the controller.
- After you set up security up for the first time, to prevent unauthorized access, log off at the end of the session. To log off, press **SPEC FUNC STATUS DISPLY** (for 2070, press **\* E**).

MM-1-7-3 Parameter	Description	Range
USER ACCOUNT	Enter the number of the User Account you want to change.	1 thru 50
NAME	<p>Use the numeric keypad to edit the user Name, which must be from 6 to 15 characters long. For the characters that each key can enter, refer to the list below.</p> <p>Repeatedly press (within one second) the key for the character you want until it comes into view.</p> <p><b>Note • Before you enter another consecutive character with the same key, wait a minimum of two seconds before you press it again.</b></p> <p><b>1</b> enters space \$ / &gt; # * ; \ " ! @ &amp; . ? = - 1</p> <p><b>2</b> enters A B C a b c 2</p> <p><b>3</b> enters D E F d e f 3</p> <p><b>4</b> enters G H I g h i 4</p> <p><b>5</b> enters J K L j k l 5</p> <p><b>6</b> enters M N O m n o 6</p> <p><b>7</b> enters P Q R S p q r s 7</p> <p><b>8</b> enters T U V t u v 8</p> <p><b>9</b> enters W X Y Z w x y z 9</p> <p><b>0</b> enters 0</p> <p><b>CLEAR</b> deletes the entire entry</p> <p>Cursor Left: clears the character in the far right column</p>	<p>1 thru 9, a thru z, A thru Z (special characters)</p>

- Security Access, MM-1-7-3

MM-1-7-3 Parameter	Description	Range
User Account ACCESS Privilege	Toggle to select: READ-ONLY: The user may view most screens but not change any values. <b>Note • All users have this privilege.</b> READ-WRITE: The user may view most screens and may change values except MM-1-7-1 (CU/CABINET INTERLOCK CRC) and MM-1-7-3 (Security Access). DIAGNOSTIC: Same as READ-WRITE with the addition of performing diagnostics that can be intrusive to normal operations. ALL: No restriction, which includes the ability to set access to a USER ACCOUNT. <b>IMPORTANT • Be careful as to whom you give this privilege.</b>	READ-ONLY READ-WRITE DIAGNOSTIC ALL
ACCESS CODE ACCESS CODE CONFIRM	<ol style="list-style-type: none"> <li><b>1</b> Use number keys to enter the ACCESS CODE value.</li> <li><b>2</b> Press the down arrow to the ACCESS CODE CONFIRM field.</li> <li><b>3</b> Enter the ACCESS CODE again.</li> </ol>	0-65535

## Logic Processor Submenu, MM-1-8

```

LOGIC PROCESSOR SUBMENU

1. LOGIC STATEMENT CONTROL

2. LOGIC STATEMENTS
    
```

### Logic Processor Statement Control, MM-1-8-1

```

LOGIC STATEMENT CONTROL
      1 2 3 4 5 6 7 8 9 0 1 2 3 4 5
LP  1-15. . . . .
LP  16-30. . . . .
LP  31-45. . . . .
LP  46-60. . . . .
LP  61-75. . . . .
LP  76-90. . . . .
LP  91-100. . . . .

      D = DISABLED      E = ENABLED
      ". " = ENABLED / DISABLED BY OTHER SOURCE
    
```

The Logic Statement Control screen selects whether or not the particular Logic Processor Statement is:

- ALWAYS enabled ('E')
- NEVER enabled ('D')
- Subject to activation or deactivation by a lower priority source (".")

The priority of Logic Processor sources, from highest to lowest is as follows:

- 1 Front Panel Selection (MM-1-8-1)
- 2 External Input
- 3 Central (Remote) Command
- 4 Time Base Action Plan (MM-5-4)
- 5 Hard-coded entries

- *Logic Processor Statements, MM-1-8-2*

## Logic Processor Statements, MM-1-8-2

The Logic Processor (LP) can hold up to 100 logic gates. A typical logic gate configuration is shown below.

```
LP# 98 COPY FROM: ACTIVE: M FALSE
IF GREEN ON PHASE 10 IS ON T
AND VEHICLE DET # 1 IS ON F
OR MINGRN TMR ON PHASE 10 < 15.7 T

THEN SET VEHICLE DET # 1 OFF
      SET GREEN OVERLAP B OFF
      SET YELLOW OVERLAP B ON

ELSE DELAY FOR 15.7 SECONDS
      SET VEHICLE DET # 1 ON
```

The Logic Processor Statements screen allows the inputs and outputs to be under logical control of conditions developed by the user.

---

**Note** • Because of the small 8-line display, users of a 2070 should use a PC-based Logic Processor Programming to make it easier to program the LP.

---

## General Programming Notes for Logic Statements, MM-1-8-2

### How to Program a Logic Processor Statement (LPS):

- 1 Go to MM-1-8-2.
- 2 In the **LP#** field, enter the number (1-100) of the LPS to program.
- 3 To select an LPS:
  - a Go to the IF, THEN or ELSE element field.
  - b Press **ENTER** to go to an expanded Select List.
  - c Use the arrows to go to the desired element.
  - d Press **ENTER** again.

---

**Note** • If you press **SUB MENU**, the Select List will not change.

---

- 4 To prevent partial LP execution, the first LP element you select when you press **ENTER** forces Transaction Mode.
- 5 To exit unchanged, press **SUB MENU**.

### Tips for Fast Navigation on LP Select Lists

- To examine different LPS that are programmed, move the cursor to the LP # field and press **NEXT DATA**. The screen will jump to the next LP # that is programmed. It wraps around at the last programmed LPS.
- To go to the next Select List screen, press **NEXT SCREEN**.
- To go to the first LPS that starts with given letter, press the key with the related letter (like a telephone key pad).

**Example:** Press **8** to go to the first “I” element and press **8** again to go to the first “U” element.

### How to Clear the Entire LPS (that is, Erase all “IFs,” “THENS,” and “ELSEs”):

- 1 Move the cursor to the LPS Number in the top line.
- 2 Press **CLEAR**.

### How to Clear a Single Testable or Executable Element:

- 1 Move the cursor to element you want to clear.
- 2 Press **CLEAR**.

### To discard all changes to a Logic Processor Statement (LPS):

- ▶ Press **SPEC FUNC/CLEAR**.

### What to do when the LPS are Completed:

- 1 Press **SPEC FUNC/ENTER** to save the changes.
- 2 Go to MM-1-8-1 or desired Action Plan.
- 3 Make sure the LPS is set to ‘E’ (enabled).

### Logic Process Status

You can see the *result* of the overall Logic Processor evaluation or of an individual element on the same menu:

When LPS is enabled, overall result is shown on top right as TRUE or FALSE.

## Configuration

### ▪ General Programming Notes for Logic Statements, MM-1-8-2

Individual result is shown in far right column, aligned with the respective Logic Processor Element

- T = True
- F = False

MM-1-8-2 Parameter	Description	Range
LP #	The number of the Logic Processor Statement (LPS) that is being programmed or viewed.  <b>Note</b> • <b>0 (zero): Selects the next open LPS starting with Logic Gate 1.</b>  <b>IMPORTANT</b> • <b>The LPS are executed in sequence once every 1/10th second from 1-100. Any condition that is to be used by a LPS must be determined before that LPS is evaluated.</b>	1-100  0 - Selects next open gate.
COPY FROM	If another LPS is similar, use this field to copy that LP Statement into the current LPS. Because most of the elements are the same, you only need to edit what is different. This is useful if similar elements are used for each traffic direction.	1-100
ACTIVE	You can <b>activate</b> MM-1-8-2 LPS by different sources. The source of the activation is shown on the ACTIVE field:  <ul style="list-style-type: none"> <li>■ A = Enabled by Action PLAN</li> <li>■ M = Enabled by MM-1-8-1 (Manual)</li> <li>■ R = Enabled by Remote command</li> <li>■ N = Not Enabled</li> </ul>	A, M, R, N
IF	A set of testable elements that are connected by operators to create a TRUE or FALSE outcome. This outcome will execute the THEN elements if TRUE and the ELSE elements if FALSE.	
(operator column)	Determines how the “IF” testable elements are combined to create a “TRUE or “FALSE.”	AND, OR, NAND, NOR, XOR
(testable element column)	Refer to Appendix L, <i>Logic Processor Operation</i> for a list of all testable elements available to the IF testable elements.	Various*



MM-1-8-2 Parameter	Description	Range
(testable element number column)	The number of the testable element *. <b>Example:</b> “2” when “VEH GREEN ON PH” (original “GREEN ON PHASE”) is the testable element represents Phase 2 Green.	Various*
(testable element operator column)	Selects how the testable element is to be compared* to the testable element value.	IS, <, >, <>*
(testable element value column)	The value that the testable element will be evaluated* to by the operator to determine the TRUE or FALSE of the testable element	ON, OFF 0-65535*
THEN	When all of the conditions of the IF elements are met, the THEN elements are executed from top to bottom.	
(executable element column)	Refer to Appendix L, <i>Logic Processor Operation</i> for a list of all executable elements available to the THEN executable element.	Various*
(executable element number column)	The number of the executable element *. <b>Example:</b> “1” when “CTR HOLD PHASE” (original “HOLD PHASE”) is the executable element represents setting or resetting Phase one Hold.	Various*
(executable element value column)	The condition that the executable element will set or the time in 1/10-second increments that the following executable elements will be delayed.	ON, OFF 0-65535*
ELSE	When all of the conditions of the IF testable element are not met, the ELSE executable elements are executed from top to bottom.	
(executable element column)	Refer to Appendix L, <i>Logic Processor Operation</i> for a list of all executable elements available to the ELSE elements.	Various*

- *Extended Logic Processor Group*

MM-1-8-2 Parameter	Description	Range
(executable element number column)	The number of the executable element *. <b>Example:</b> “1” when “CTR HOLD PHASE” (original “HOLD PHASE”) is the executable element represents setting or resetting Phase one Hold.	Various*
(executable element value column)	The condition that the executable element will set or the time in 1/10-second increments that the following executable elements will be delayed.	ON, OFF 0-65535*

## Extended Logic Processor Group

You can turn ON and OFF a group of *ASC/3* Logic Processor Statements (LPS). These statements are in the range of 101-200 and can be programmed with the *ASC/3* Controller Configurator run on a PC.

You have to program allowable LP # range (group of LP) in the ASC3.ext file. Give it a name (LP feature 1).

Then you can turn LP feature group 1 ON and OFF with MM-2-6-2.

---

**Note** • The last LP group will precede the earlier group if the LP # is overlapped Format.

---

### Comment Statement

A line that starts with the " character will not be processed. This is used to put comments in the file.

### Message

A line that starts with 'CONFIG=', the text after the '=' will be displayed in the sign-on screen and MM-2-6-2. Max number of characters is 12.

This is optional. For example:

CONFIG= Any City

## Control Statements

These are used to specify which LP Statements you can turn ON or OFF.

Max number of control statements is 25. The format is:

<on/off>, <start LP>, <end LP>, <Text>

Parameter	Description
<on/off>	0 = Turn OFF feature at power ON. 1 = Turn ON feature at power ON.
<start LP>	Starting LP Statement. Range is from 101 - 200
<end LP>	Ending LP Statement. Range is from 101 - 200
<Text>	Text is shown in MM-2-6-2 for the corresponding feature. Max length is 36 characters.

### For example:

<p><b>asc3.ext</b></p> <pre>CONFIG=AnyCity 1,101,106, IDOT 5 SECTION HEAD CONTROL 0,107,111,LP FEATURE 0,112,113,CANADIAN LEFT TURN</pre>	<p><b>Display on MM-2-6-2</b></p> <pre>EXTENDED OPTIONS  IDOT 5 SECTION HEAD CONTROL      ON LP FEATURE                        OFF CANADIAN LEFT TURN                OFF</pre>
---	--

1st LPS group “IDOT 5 SECTION HEAD CONTROL” specifies a group of LPS from 101 and 106 that can be turned ON or OFF together. Default is ON (1 on first left of asc3.ext).

2nd LPS group “LP FEATURE” specifies a group of LPS from 107 and 111 that can be turned ON or OFF together. Default is OFF (0 on first left of asc3.ext).

3rd LPS group “CANADIAN LEFT TURN” specifies a group of LPS from 112 and 113 that can be turned ON or OFF together. Default is OFF (0 on first left of asc3.ext).

Refer to Appendix L, *Logic Processor Operation* for more Logic Processor definitions.

- *Control Statements*

---

**For your notes:**

## Configuration

---

- *Control Statements*

# Controller

## Controller Submenu, MM-2

### Programming Summary

CONTROLLER SUBMENU	
1. TIMING PLANS	5. START/FLASH
2. VEHICLE OVERLAPS	6. OPTION DATA
3. VEH/PED OVERLAPS	7. PRE-TIMED
4. GUAR MIN TIME	8. PHASE RECALL

MM-2 Menu Option	Programming Summary
1. TIMING PLANS	Enter phase timing values for each of 16 phases and four timing plans.
2. VEHICLE OVERLAPS	Select the Overlap Type: OTHER/ECONOLITE, NORMAL, -GRN/YEL, or PPL/FYA  Enable trailing, leading or overlap flashing, etc. as applicable  Enter timing values for trailing and advanced green for the applicable overlap types.
3. VEH/PED OVERLAPS	Assign phase(s) to each of 16 (Included, Protected, Modifier, Pedestrian Protect, and not Overlap) vehicle or pedestrian overlaps.
4. GUAR MIN TIME	Enter guaranteed minimum times (Minimum Green, Walk, Pedestrian Clearance, Yellow and Red Clearance) for each of 16 phases.  Enter guaranteed minimum Green times for each of 16 overlaps.

▪ *Timing Plans, MM-2-1*

MM-2 Menu Option	Programming Summary
5. START/FLASH DATA	Select active phase(s), overlap(s) and interval at power start. Select entry automatic flash phase(s). Select exit automatic flash phase(s) overlap(s) and colors. Set power start timing for All Red and Flash. Enable minimum vehicle recall before entering automatic flash. Enable flash through the load switches. Set minimum automatic flash time. Enable cycle through phases before going into automatic flash.
6. OPTION DATA	Access the Option submenu with two data groups that allow programming of controller phase and extended options.
7. ACT PRE-TIMED	Assign phase(s) that are to time as pre-timed. Enable the free input to disable pre-timed operation.
8. PHASE RECALL	Provides ability to select options that include: Lock Detector, Vehicle Recall, Pedestrian Recall, MX (Max) Recall, SF (Soft) Recall, No Rest, and AI (Added Initial) Calculation for phases 1 thru 16.

*Timing Plans, MM-2-1*

**General Information**

The Phase Timing Plans establish which phase intervals will time and their time. The interval time entries that require additional enabling are described in the paragraphs following the screen illustrations. Those that do not require additional enabling are described in the table that follows those paragraphs.

**To do data entry/storage:**

- 1** Enter data using the keypad number, cursor, and **ENTER** keys. Move cursor up/down to the desired parameter then right/left to the desired phase number.
- 2** To store the data, enter the timing value, then press **ENTER** or any other keypad key.



Data in MM-2-1 and MM-2-8 are in the same plan and would execute together, so these displays are hyperlinked.

TIMING PLAN [ 1 ] PHASE DATA																
PHASE	1	2	3	4	5	6	7	8	9	10	11	12	13	14	15	16
MIN GRN	5	5	5	5	5	5	5	5	5	5	5	5	5	5	5	5
BK MGRN	0	0	0	0	0	0	0	0	0	0	0	0	0	0	0	0
CS MGRN	0	0	0	0	0	0	0	0	0	0	0	0	0	0	0	0
DLY GRN	0	0	0	0	0	0	0	0	0	0	0	0	0	0	0	0
WALK	0	0	0	0	0	0	0	0	0	0	0	0	0	0	0	0
WALK2	0	0	0	0	0	0	0	0	0	0	0	0	0	0	0	0
WLK MAX	0	0	0	0	0	0	0	0	0	0	0	0	0	0	0	0
PED CLR	0	0	0	0	0	0	0	0	0	0	0	0	0	0	0	0
PD CLR2	0	0	0	0	0	0	0	0	0	0	0	0	0	0	0	0
PC MAX	0	0	0	0	0	0	0	0	0	0	0	0	0	0	0	0
PED CO	0	0	0	0	0	0	0	0	0	0	0	0	0	0	0	0
VEH EXT	0.0	0.0	0.0	0.0	0.0	0.0	0.0	0.0	0.0	0.0	0.0	0.0	0.0	0.0	0.0	0.0
VH EXT2	0.0	0.0	0.0	0.0	0.0	0.0	0.0	0.0	0.0	0.0	0.0	0.0	0.0	0.0	0.0	0.0
MAX 1	35	35	35	35	35	35	35	35	35	35	35	35	35	35	35	35
MAX 2	35	35	35	35	35	35	35	35	35	35	35	35	35	35	35	35
MAX 3	35	35	35	35	35	35	35	35	35	35	35	35	35	35	35	35
DYM MAX	0	0	0	0	0	0	0	0	0	0	0	0	0	0	0	0
DYM STP	0	0	0	0	0	0	0	0	0	0	0	0	0	0	0	0
YELLOW	0.0	0.0	0.0	0.0	0.0	0.0	0.0	0.0	0.0	0.0	0.0	0.0	0.0	0.0	0.0	0.0
RED CLR	0.0	0.0	0.0	0.0	0.0	0.0	0.0	0.0	0.0	0.0	0.0	0.0	0.0	0.0	0.0	0.0
RED MAX	0.0	0.0	0.0	0.0	0.0	0.0	0.0	0.0	0.0	0.0	0.0	0.0	0.0	0.0	0.0	0.0
RED RVT	0.0	0.0	0.0	0.0	0.0	0.0	0.0	0.0	0.0	0.0	0.0	0.0	0.0	0.0	0.0	0.0
ACT B4	0	0	0	0	0	0	0	0	0	0	0	0	0	0	0	0
SEC/ACT	0.0	0.0	0.0	0.0	0.0	0.0	0.0	0.0	0.0	0.0	0.0	0.0	0.0	0.0	0.0	0.0
MAX INT	0	0	0	0	0	0	0	0	0	0	0	0	0	0	0	0
TIME B4	0	0	0	0	0	0	0	0	0	0	0	0	0	0	0	0
CARS WT	0	0	0	0	0	0	0	0	0	0	0	0	0	0	0	0
STPTDUC	0.0	0.0	0.0	0.0	0.0	0.0	0.0	0.0	0.0	0.0	0.0	0.0	0.0	0.0	0.0	0.0
TTREDUC	0	0	0	0	0	0	0	0	0	0	0	0	0	0	0	0
MIN GAP	0.0	0.0	0.0	0.0	0.0	0.0	0.0	0.0	0.0	0.0	0.0	0.0	0.0	0.0	0.0	0.0

When in a **hyperlink** field:

To follow the **hyperlink**:

For ASC/3, press **SPEC FUNC**, then **NEXT DATA**.

For 2070, press **B**.

To go back:

For ASC/3, press **SUB MENU**.

For 2070, press **ESC**.

MM-2-1 Parameter	Description	Range
TIMING PLAN	Selects the timing plan to edit or view.	1-4
MIN GRN	<p><b>Minimum Green (initial green)</b></p> <p>The shortest possible vehicle green time, before any added initial or vehicle extensions.</p> <p><b>Note</b> • Actual minimum green indication is the longest of the minimum green plus any added initial, vehicle extension, bike minimum green, ped walk plus ped clearance, or guaranteed minimum green*.</p>	0-255 sec.
BK MGRN	<p><b>Bike Minimum Green</b></p> <p>The minimum green due to a bike detector call. Bike minimum green has no effect if the phase has no bike detector input.</p>	0-255 sec.
CS MGRN	<p><b>Conditional Service Minimum Green</b></p> <p>The minimum green time for a phase being conditionally serviced.</p>	0-255 sec.

▪ Timing Plans, MM-2-1

MM-2-1 Parameter	Description	Range
DLY GRN	<p><b>Delayed Green</b></p> <p>The time that the vehicle green indication is delayed from the start of the walk interval. The delay is ignored if there is no pedestrian service call when the phase is started. If the delay time is greater than the Walk time, the walk is extended to the end of delay green.</p>	0-255 sec.
WALK	<p><b>Pedestrian Walk</b></p> <p>Time during which WALK or walking person symbol is displayed when servicing a ped call.</p> <p>WALK or PED CLR timing cannot be programmed to zero if the phase is the ped carryover start phase or part of a ped overlap.</p> <p><b>Note</b> • Actual walk time is the longer of the walk time in effect or guaranteed* walk.</p>	0-255 sec. 0 disables
WALK 2	<p><b>Pedestrian Walk 2</b></p> <p>WALK 2 defines the duration of the interval in which WALK or the walking person symbol is displayed following a ped call from the WALK 2 input. If it is not a larger value, it is replaced by guaranteed WALK Time (MM-2-4). If WALK 2 is zero and enabled, the Walk time is substituted.</p> <p><b>Note</b> • Actual walk time is the longer of the walk time in effect or guaranteed* walk.</p>	0-255 sec.
WLK MAX	<p><b>Walk Maximum</b></p> <p>When the walk in effect has been timed: if the phase's Ped Extend Detector is TRUE, the walk is extended until 1) its total length reaches Walk Maximum, or 2) the elapsed length of the walk extension plus the ped clear equals the max in effect, or 3) the Ped Extend Detector input goes false. Walk maximum time has no effect when there is not a pedestrian extend detector for the phase.</p>	0-255 sec.
PED CLR	<p><b>Pedestrian Clearance</b></p> <p>Time during which DON'T WALK or hand symbol is flashing following pedestrian WALK time.</p> <p>WALK or PED CLR timing cannot be programmed to zero if the phase is the ped carryover start phase or part of a ped carryover.</p> <p><b>Note</b> • Actual pedestrian clearance time is the longer of the pedestrian clearance in effect or guaranteed* pedestrian clearance.</p>	0-255 sec.

MM-2-1 Parameter	Description	Range
PD CLR 2	<p><b>Pedestrian Clearance 2</b></p> <p>Pedestrian clearance time that is to be in effect when WALK 2 is enabled by a time base Action Plan (MM-5-4). This is the time during which DON'T WALK or the hand symbol is flashing following ped WALK time.</p> <p><b>Note</b> • Actual pedestrian clearance time is the longer of the pedestrian clearance in effect or guaranteed* pedestrian clearance.</p>	0-255 sec.
PC MAX	<p><b>Pedestrian Clearance Maximum Time</b></p> <p>This is an ECPI feature.</p> <p>(Applies to TS1 and TS2 operation)</p> <p>The Pedestrian Clearance indication can be extended to the smaller of the two values by the phase ped extend input.</p> <ul style="list-style-type: none"> <li>■ PC Max time</li> <li>■ Phase Max time remaining</li> </ul>	0-255 sec. by timing plan (1-4)
PED CO	<p><b>Pedestrian Carryover</b></p> <p>If phase's pedestrian service can be carried over into another phase in the same ring when that phase times next, enter the phase that is allowed to time next while the pedestrian service (pedestrian carryover) is completed. If the phase identified as the pedestrian carryover phase doesn't have a vehicle call or won't to be serviced next, the pedestrian service will be completed before the initiating phase is allowed to terminate. This option allows two vehicle movements while pedestrians are crossing wide streets.</p> <p><b>Note</b> • A pedestrian carryover service is not permitted to be part of a Pedestrian Overlap.</p>	0-16
VEH EXT	<p><b>Phase Vehicle Extension (Preset gap, Passage Time)</b></p> <p>When minimum green finishes timing, the green interval is allowed to extend for a length of time equal to maximum time in effect. Actual length of extension period depends on this phase vehicle extension time, frequency of vehicle actuations and minimum gap setting.</p> <p><b>Note</b> • Detector-by-Detector extension time can be set in the vehicle detector setup screen (MM-6-2).</p>	0-25.5 sec.
VEH EXT2	<p><b>Phase Vehicle Extension 2</b></p> <p>Vehicle Extension period 2 operates like VEH EXT. VEH EXT2 replaces VEH EXT when its usage is enabled by the selected time base Action Plan (MM-5-4).</p>	0-25.5 sec.

- Timing Plans, MM-2-1

MM-2-1 Parameter	Description	Range
MAX 1, 2, 3	<p><b>Maximum Green (1, 2, 3)</b></p> <p>Maximum green time allowed in the presence of an opposing call.</p> <p><b>Note • The higher numbered maximum green selected is in effect.</b></p>	0-255 sec.
DYM MAX	<p><b>Dynamic Maximum</b></p> <p>Determines the upper or lower limit of the running max time. The max in effect (*MAX 1, 2, or 3) determines the other limit.</p> <p>When a phase maxes out twice in a row, and on each successive max out thereafter, the running max is incremented one dynamic max step until it reaches the dynamic maximum upper limit.</p> <p>When a phase gaps out twice in a row, and on each successive gap out thereafter, the running max is decremented one dynamic max step until it reaches the dynamic maximum lower limit.</p> <p>If a phase gaps out in one cycle and maxes out in the next cycle, or vice versa, the running max is not changed.</p> <p>Refer to Phase Dynamic Max Limit described in NTCIP 1202 paragraph 2.2.2.17 for a more complete explanation.</p> <p><b>Note • When DYM MAX is not used (DYM MAX = 0), the maximum green time is equal to the selected max timer (MAX 1, 2 or 3).</b></p>	0-255 sec. 0 disables
DYM STP	<p><b>Dynamic Step</b></p> <p>The amount of time that the running max time is increased or decreased by max or gap out.</p> <p>Refer to Phase Dynamic Max Step described in NTCIP 1202 paragraph 2.2.2.18 for a more complete explanation.</p>	0-25.5 sec.
YELLOW	<p><b>Yellow Change</b></p> <p>The time that the phase yellow indication is displayed following a green interval.</p> <p><b>Note • Actual yellow change in effect is the longest of yellow change or guaranteed* yellow.</b></p>	0-25.5 sec.
RED CLR	<p><b>Red Clearance</b></p> <p>The time that the phase red indication is displayed following a yellow change interval when terminating the phase.</p> <p><b>Note • Actual red clearance time in effect is the longest of the red clearance or guaranteed* red clearance.</b></p>	0-25.5 sec.

MM-2-1 Parameter	Description	Range
RED MAX	<p><b>Red Maximum</b></p> <p>When the red clearance in effect has been timed, if the phase's Red Extend Detector is TRUE, red clearance is extended until its total length reaches Red Maximum or the Red Extend Detector input goes FALSE. Red Maximum has no effect when there isn't a red extend detector for the phase.</p>	0-25.5 sec.
RED RVT	<p><b>Red Revert</b></p> <p>Minimum red time before a phase can be re-serviced. Red revert begins timing at the start of red clearance. The actual red revert time for any phase is the larger of this and the Unit Red Revert time (MM-2-6-1).</p> <p><b>IMPORTANT</b> • NEMA mandates minimum limit time setting at 2 seconds. NTCIP allows for this value to be set lower.</p>	0.0-25.0 sec.
ACT B4	<p><b>Actuations Before</b></p> <p>Number of actuations that must be received during the phase's yellow and red intervals before seconds per actuation time is added to initial green.</p>	0-255 actuations
SEC/ACT	<p><b>Seconds per actuation (Added Initial)</b></p> <p>Time by which the phase's added initial time period is increased from zero for each vehicle actuation received during the phase's yellow and red intervals that exceed the Actuations Before limit.</p>	0-25.5 sec.
MAX INT	<p><b>Maximum Added Initial</b></p> <p>Maximum time that added initial green can attain. The number of vehicle actuations received during a phase's yellow and red intervals multiplied by the seconds per actuation time cannot exceed this time.</p>	0-255 sec.
TIME B4	<p><b>Time Before (Reduction)</b></p> <p>Length of time before start of gap reduction. Begins timing when phase is green and there is a conflicting serviceable call.</p> <p><b>Note</b> • Start of gap reduction (time to reduce or step to reduce) is initiated by TIME B4 or CARS WT, whichever reaches its programmed value first.</p>	1-255 sec. 0 disables
CARS WT	<p><b>Cars Waiting before reduction</b></p> <p>Number of vehicle detections that have been recorded on all conflicting phases during their yellow and red intervals.</p> <p><b>Note</b> • Start of gap reduction (time to reduce or step to reduce) is initiated by TIME B4 or CARS WT, whichever reaches its programmed value first.</p>	1-255 cars 0 disables

- Vehicle Overlap, MM-2-2

MM-2-1 Parameter	Description	Range
STPTDUC	<p><b>Step To Reduce</b></p> <p>Step reduction: When gap reduction starts and STPTDUC isn't zero, TTREDUC multiplied by 10 is divided by STPTDUC to calculate the number of 1/10 second cycles timed between each reduction step. By the time the TTREDUC interval has completed its timing, vehicle extension in effect will have been reduced the MIN GAP.</p> <p>Linear reduction: When gap reduction starts and STPTDUC is zero, MIN GAP is subtracted from the vehicle extension in effect and that value is divided by the product of TTREDUC multiplied by 10. The result is subtracted from vehicle extension in effect every 1/10 second until vehicle extension in effect is reduced to the MIN GAP.</p>	<p>0.1-25.5 sec. / step 0 = linear</p>
TTREDUC	<p><b>Time To Reduce</b></p> <p>Length of time between the start and end of gap reduction. During the Time to Reduce interval, the vehicle extension in effect is reduced from its initial time down to the specified MIN GAP time.</p>	<p>0-255 sec.</p>
MIN GAP	<p><b>Minimum Gap</b></p> <p>Minimum vehicle extension to be timed for each vehicle actuation. If the minimum vehicle extension times out before a vehicle actuation is received and the timer is restarted, gap out occurs.</p>	<p>0-25.5 sec.</p>

\* Guaranteed minimum values are programmed in MM-2-4.

## Vehicle Overlap, MM-2-2

### Overlap Data

You can program four types of overlaps:

- Normal
- Minus Green Yellow (-GRN/YEL)
- PPLT FYA
- Other/Econolite

Normal and Minus Green Yellow operate per the requirement specified in NTCIP 1202 paragraph 2.10.2.2. PPLT FYA uses overlap so you can program Protected Permissive left hand turns. Type Other/Econolite identifies overlaps that supplement the Normal overlap with the Econolite-specific options.

**To select an overlap type in MM-2-2:**

- 1 Move the cursor to the TYPE field.
- 2 Toggle again and again as necessary.
- 3 After the desired type of overlap comes into view, move the cursor to another field to automatically refresh the screen to only show the parameters related to the overlap you selected.

The table that follows describes the four types of overlaps and shows the screens for each type.

**TYPE: Types of Vehicle Overlaps in MM-2-2**

NORMAL	
<div style="border: 1px solid black; padding: 5px; width: fit-content; margin: auto;"> <pre> TMG VEH OULP...[A] TYPE: .....NORMAL PHASES 1 2 3 4 5 6 7 8 9 0 1 2 3 4 5 6 INCLUDED . . . . . LAG GRN 0.0 YEL 0.0 RED 0.0                     </pre> </div>	
The state of the Included Phases of the overlap determines the output, as given below:	
Included Phase	Overlap Output
Green	Green
Yellow or Red Clearance -and- one of these phases is Next (For example, Overlap A = 1+2. 1 Terminates and 2 is Next)	
Yellow and no included phase is Next	Yellow
Green and Yellow OFF	Red

- Vehicle Overlap, MM-2-2

**TYPE: Types of Vehicle Overlaps in MM-2-2 (cont.)**

**-GRN/YEL  
Minus Green Yellow**

```

TMG VEH OULP...[A] TYPE: .....-GRN/YEL
PHASES 1 2 3 4 5 6 7 8 9 0 1 2 3 4 5 6
INCLUDED . . . . .
MODIFIER . . . . .
                
```

The state of the Included Phases and the Modifier Phase Assignments of the overlap determine the output.

This is used to avoid conflicting movements between modifier phase and overlap.

For example, Overlap A=1. Modifier phase is 6. Phase 6 is in conflict with Overlap A. When 6 is ON or Next, Overlap A is NOT ON.

Included Phase	Modifier Phase	Overlap Output
Green	NOT Green	Green
Yellow or Red Clearance and one is Next		
Yellow and NOT Next	NOT Yellow	Yellow
Green and Yellow OFF	-----	Red

**PPLT FYA  
Protected Permissive Left Turn Flashing Yellow Arrow**

```

TMG VEH OULP...[A] TYPE: .....PPLT FYA
PROTECTED PHASE (LEFT TURN)..... 0
PERMISSIVE PHASE (OPPOSING THRU).... 0
FLASHING ARROW OUTPUT.....CH 0 YEL PED

DELAY START OF: FYA..0.0 CLEARANCE..0.0
ACTION PLAN SF BIT DISABLE..... 0
                
```

This is a special Econolite overlap type for Protected/Permissive Left Turns using the Flashing Yellow Arrow. It changes programmed controller outputs to meet NEMA specification and requires a compliant MMU or CMU.



**TYPE: Types of Vehicle Overlaps in MM-2-2 (cont.)**

**OTHER/ECONOLITE**

```

TMG VEH OVLP...[A] TYPE:OTHER/ECONOLITE
 PHASES 1 2 3 4 5 6 7 8 9 0 1 2 3 4 5 6
INCLUDED . . . . .
PROTECT . . . . .
PED PRTC . . . . .
NOT OVLP . . . . .
FLSH GRN . . . . .
LAG X PH . . . . .
LAG 2 PH . . . . .

LAG GRN 0.0 YEL 0.0 RED 0.0 ADV GRN 0.0
    
```

The Other/Econolite type is altered by the selected usage of these parameters:  
 Protect; Pedestrian Protect; Not Overlap; Flash Overlap Green; Lag (Trailing) Overlap; Lead Overlap;  
 Lag (Trailing) Green, Yellow & Red; Advance Green.

MM-2-2 Parameter	Description	Range
TMG VEH OVLP	<b>Timing Vehicle Overlap</b> Enter the desired overlap, A thru P, to edit or view that overlap.	A thru P
<b>Parameter for NORMAL, - GRN/YEL and OTHER/ECONOLITE</b>		
INCLUDED	<b>Overlap Included Phases</b> The Included Phases specify the phases whose timing state is used to derive the state of the overlap.  In general terms, when any included phase is timing its green interval or the controller is advancing from one included phase to another included phase, the overlap will be green. If no included phase is green, then the overlap will be yellow when any included phase is yellow. If no included phase is green or yellow, the overlap will be red. The normal derivation of the overlap's state can be altered by using any of the programming options described below.	'X' selects

- Vehicle Overlap, MM-2-2

MM-2-2 Parameter	Description	Range
<b>Parameters only for NORMAL and OTHER/ECONOLITE</b>		
LAG GRN, YEL, RED	<p><b>Lag (Trailing) Green, Yellow and Red times</b></p> <p>Normally, if an included phase is terminating and no other included phase is timing or a phase next selection, the terminating included phase's yellow and red are also output to the overlap. Trailing Green, Yellow, and Red provide a means of extending the overlap's green and then timing a specified yellow and red. When the last timing overlap included phase begins its yellow change, the overlap's green interval is extended by the specified Trailing Green time. After Trailing Green has timed, Trailing Yellow and Trailing Red times are used to time the overlap's yellow change and red clearance intervals.</p> <p><b>Note</b> • Lagging times take effect only if the if the GREEN and YELLOW entries are both non-zero.</p>	0-25.5 sec.
<b>Parameter only for - GRN/YEL (Minus Green Yellow)</b>		
MODIFIER	<p><b>Modifier Phases</b></p> <p>Used when the overlap type is MINUS GREEN YELLOW to provide an overlap that will terminate to red during a modifier phase green and yellow.</p> <p><b>Note</b> • When Modifier phases are assigned, only it and the Included Phases option are used to derive the state of the overlap. All other overlap programming options are ignored.</p>	'X' selects
<b>Parameters only for PPLT FYA (Protected Permissive Left Turn Flashing Yellow Arrow)</b>		
PROTECTED PHASE (LEFT TURN)	ASSIGN the left turn phase number associated with the PPLT/FYA. This phase represents the protected turning movement. An assignment of zero disables the feature.	0-16
PERMISSIVE PHASE (OPPOSING THRU)	ASSIGN the opposing through movement in which the left turn phase is permitted for PPLT/FYA. When the assigned phase is timing green or timing with the protected left turn as a next phase decision, then the FLASHING YELLOW ARROW output will be active.	0-16

MM-2-2 Parameter	Description	Range
<b>Parameters only for PPLT FYA (Protected Permissive Left Turn Flashing Yellow Arrow), continued</b>		
FLASHING ARROW OUTPUT CHANNEL	<p><b>IMPORTANT</b> • <b>MMU/CMU must be validated for compatibility before attempting to program this feature. ASSIGN the output mode for the load switch assignment on either the protected or permissive phase.</b></p> <p><b>GRN OLP:</b> Connect the wire of the Flashing Yellow Arrow (FYA) signal to the GREEN output on the assigned overlap load switch channel (MM-1-3) which is indicated by the CH—read-only field. Note that the protected and permissive left turn clearance intervals will be the same on the overlap and phase load switch channels.</p> <p><b>YEL PED:</b> Connect the wire of the Flashing Yellow Arrow (FYA) signal to the YELLOW output on the assigned permissive through load switch channel (MM-1-3) which is indicated by the CH—read-only field.</p> <p><b>ISOLATE (Isolate Protected Green):</b> Connect the wire of the Flashing Yellow Arrow (FYA) signal to the GREEN output on the assigned overlap load switch channel. The protected and permissive left turn clearance outputs will also be located on the overlap load switch channel. ISOLATE refers to the isolated green indication remaining on the original protected left turn channel. This is based on the EDI “BASIC FYA MODE.”</p>	GRN OLP, PED YEL, ISOLATE
DELAY START OF FYA	<p>ASSIGN the period of time in tenths-of-a-second to delay flashing the yellow arrow output once the permissive through movement begins timing green. This is a safety feature that will limit the exposure of left turning vehicles because it is assumed that opposing queued vehicles will not provide adequate headway. This delay timer will not apply during preemption. The channel output will be red.</p> <p><b>Note</b> • <b>To make sure that the flashing interval duration is at least two seconds, a phase HOLD is applied to make sure the parent opposing through movement does not terminate too soon. If the opposing through phase has reached yellow clearance before the delay start timer expires, then the FYA channel output remains in red.</b></p>	0 -25.5 seconds
DELAY START OF CLEARANCE	<p>ASSIGN the period of time in tenths-of-a-second to continue flashing the yellow arrow output once the permissive through movement reaches yellow clearance. This is a safety feature that will limit the exposure of providing two conflicting solid yellow clearance arrows in PPLT/FYA operation.</p>	0-25.5 seconds

- Vehicle Overlap, MM-2-2

MM-2-2 Parameter	Description	Range
<b>Parameters only for PPLT FYA (Protected Permissive Left Turn Flashing Yellow Arrow), continued</b>		
ACTION PLAN SF BIT DISABLE	<p><b>1-8:</b> ASSIGN the bit number that can be used in an Action Plan (MM-5-2) to disable the permissive left turn by time-of-day.</p> <p><b>0 (zero):</b> PPLT/FYA will not be disabled by a Special Function Bit.</p> <p><b>Note</b> • <b>Disabling PPLT/FYA while the permissive phase is either timing or assigned as a next phase will not take effect until the permissive phase has completed the timing interval.</b></p>	0-8
<b>Parameters only for OTHER/ECONOLITE</b>		
PROTECT	<p><b>Protected Overlap</b></p> <p>A movement having a protected green arrow (no conflicting phases timing).</p> <p><b>Note</b> • <b>When a phase has protected overlap phase assignments, Modifier, Lead, and Trailing assignments are ignored (inhibited).</b></p>	'X' selects
PED PRTC	<p><b>Pedestrian Protect</b></p> <p>The Pedestrian Protect option provides for the specification of phase pedestrian movements that cannot be serviced while the overlap is active. If a pedestrian call is present on a pedestrian protected phase when that phase becomes the phase next selection, the overlap is terminated while the ring transitions from the timing phase to the phase with the protected pedestrian service. If a pedestrian call is not present when the pedestrian protected phase becomes the phase next selection, the overlap remains active if an included phase is timing or a phase next selection. Should a pedestrian call be input while the ring is in yellow change or red clear on the way to the pedestrian protected phase, the overlap is not terminated until the pedestrian protected phase starts and then only if there is enough time to terminate the overlap and time the pedestrian movement before the phase will max out.</p>	'X' selects

MM-2-2 Parameter	Description	Range
<b>Parameters only for OTHER/ECONOLITE, continued</b>		
NOT OVLP	<p><b>Not Overlap</b></p> <p>The Not Overlap option is provided to inhibit the activation of an overlap when selected phases are timing. If an overlap is active when a call is placed on a not overlap phase, the phase is not allowed to time until the overlap is terminated. If the order of rotation would normally allow the not overlap phase to time, overlap termination will be initiated even if an overlap included phase is timing or a phase next selection.</p> <p>To select a not overlap inhibit phase, position the cursor on the desired NOT OLP phase and toggle the “0” key.</p>	‘X’ selects
FLSH GRN	<p><b>Flash Overlap Green</b></p> <p>Flash Overlap Green is specified for each included phase of an overlap and defines the rate at which the overlap green interval is to flash when the included phase is timing. To select a flash rate, position the cursor on the appropriate FLSH GRN phase entry and toggle the “0” key to cycle to the desired rate. The allowable flash settings are as follows:</p> <ul style="list-style-type: none"> <li>“.” = no flash or phase is not an included phase for the overlap</li> <li>1 = flash at 1 pps.</li> <li>2 = flash at 2.5 pps.</li> <li>5 = flash at 5 pps.</li> </ul> <p>The flash is extended across the transition from one included phase to another included phase if their flash rates are the same.</p> <p>Overlap green will be solid when transitioning between included phases that have different flash rates.</p>	“.”, 1, 2, and 5
LAG X PH	<p><b>Lag (Trailing) Overlap Phases</b></p> <p>This option identifies which phases are to time programmed trailing green, yellow, and red. If Trailing phases are defined, only those phases will time trailing green, yellow, and red when they advance to yellow change and no other included phase is timing or a phase next selection. If no Trailing phases are defined, then trailing green, yellow, and red are disabled.</p>	‘X’ selects

- Vehicle Overlap, MM-2-2

MM-2-2 Parameter	Description	Range
<b>Parameters only for OTHER/ECONOLITE, continued</b>		
LAG 2 PH	<p><b>Lead Overlap Phases</b></p> <p>When the overlap is active, the last timing overlap included phase is advancing to yellow, no included phase is a phase next selection, and a Lead phase (that is not an included phase) is next, trailing green, yellow, and red will be timed. This operation may be thought of as timing a lagging overlap when proceeding to a particular phase.</p> <p>When the overlap is not active and a Lead phase that is an included phase is a phase next selection, overlap advance green will be displayed. Overlap advance green output starts, defined by the ADV GRN time, when the phase of the ring that is transitioning to the included Lead phase begins its yellow service.</p> <p><b>Note</b> • The ADV GRN time takes effect only if the lagging YELLOW time is non-zero.</p>	'X' selects
ADV GRN	<p><b>Advance Green</b></p> <p>Advance Green specifies the minimum amount of overlap advance green to be displayed before a phase next selected included lead phase is started. If the amount of advance green is less than the yellow change time and red clear timed by a ring before its phase next included lead phase can be started, the overlap advance green is extended. If the amount of advance green is greater than the yellow change and red clear timed by the ring before the overlap lead phase next selection would normally start, the terminating ring phase's red clearance is extended until the advance green time is satisfied.</p> <p>Overlap advance green output starts when the phase of the ring that is transitioning to the included Lead phase begins its yellow service.</p>	0-25.5 sec.

## Vehicle or Pedestrian Overlaps, MM-2-3

VEH/PED OVERLAPS																
INCLUDED	1	2	3	4	5	6	7	8	9	0	1	2	3	4	5	6
VEH OL A	.	.	.	.	.	.	.	.	.	.	.	.	.	.	.	.
VEH OL B	.	.	.	.	.	.	.	.	.	.	.	.	.	.	.	.
VEH OL C	.	.	.	.	.	.	.	.	.	.	.	.	.	.	.	.
VEH OL D	.	.	.	.	.	.	.	.	.	.	.	.	.	.	.	.
VEH OL E	.	.	.	.	.	.	.	.	.	.	.	.	.	.	.	.
VEH OL F	.	.	.	.	.	.	.	.	.	.	.	.	.	.	.	.
VEH OL G	.	.	.	.	.	.	.	.	.	.	.	.	.	.	.	.
VEH OL H	.	.	.	.	.	.	.	.	.	.	.	.	.	.	.	.
VEH OL I	.	.	.	.	.	.	.	.	.	.	.	.	.	.	.	.
VEH OL J	.	.	.	.	.	.	.	.	.	.	.	.	.	.	.	.
VEH OL K	.	.	.	.	.	.	.	.	.	.	.	.	.	.	.	.
VEH OL L	.	.	.	.	.	.	.	.	.	.	.	.	.	.	.	.
VEH OL M	.	.	.	.	.	.	.	.	.	.	.	.	.	.	.	.
VEH OL N	.	.	.	.	.	.	.	.	.	.	.	.	.	.	.	.
VEH OL O	.	.	.	.	.	.	.	.	.	.	.	.	.	.	.	.
VEH OL P	.	.	.	.	.	.	.	.	.	.	.	.	.	.	.	.
PD OL 01	.	.	.	.	.	.	.	.	.	.	.	.	.	.	.	.
PD OL 02	.	.	.	.	.	.	.	.	.	.	.	.	.	.	.	.
PD OL 03	.	.	.	.	.	.	.	.	.	.	.	.	.	.	.	.
PD OL 04	.	.	.	.	.	.	.	.	.	.	.	.	.	.	.	.
PD OL 05	.	.	.	.	.	.	.	.	.	.	.	.	.	.	.	.
PD OL 06	.	.	.	.	.	.	.	.	.	.	.	.	.	.	.	.
PD OL 07	.	.	.	.	.	.	.	.	.	.	.	.	.	.	.	.
PD OL 08	.	.	.	.	.	.	.	.	.	.	.	.	.	.	.	.
PD OL 09	.	.	.	.	.	.	.	.	.	.	.	.	.	.	.	.
PD OL 10	.	.	.	.	.	.	.	.	.	.	.	.	.	.	.	.
PD OL 11	.	.	.	.	.	.	.	.	.	.	.	.	.	.	.	.
PD OL 12	.	.	.	.	.	.	.	.	.	.	.	.	.	.	.	.
PD OL 13	.	.	.	.	.	.	.	.	.	.	.	.	.	.	.	.
PD OL 14	.	.	.	.	.	.	.	.	.	.	.	.	.	.	.	.
PD OL 15	.	.	.	.	.	.	.	.	.	.	.	.	.	.	.	.
PD OL 16	.	.	.	.	.	.	.	.	.	.	.	.	.	.	.	.

### To Program Overlaps:

- ▶ TOGGLE to include (X) or exclude (“.”) each vehicle or pedestrian movement from the overlap.

A vehicle or pedestrian overlap (1-16) overrides the service output of the phase having the same number (1-16). This provides for a total of 16 possible vehicle or pedestrian overlaps.

A vehicle or pedestrian overlap is programmed by specifying phases with vehicle or pedestrian service whose movements are to be used to derive the overlap’s outputs.

### More Information on Pedestrian Overlap

Whenever a pedestrian overlap included phase is timing a walk or the controller is transitioning from a walk end condition on a timing phase to a walk service on another overlap included phase, the overlap will display walk. When no ped included phase is

**Controller**

▪ *Vehicle or Pedestrian Overlaps, MM-2-3*

timing a walk and is *not* a phase next selection with a ped call, the overlap will display pedestrian clearance as long as any included ped phase is timing a ped clearance. When all included ped phases are in don't walk, the ped overlap will display don't walk.

A preemptor can terminate a pedestrian overlap at any time. The preemption can override a preempted phase's ped walk and clearance time and those override times will be used to terminate the overlap. Refer to *Preemption Entrance Minimum Times* on page 9-19 for the Preemptor Walk and Pedestrian Clearance program options (MM-4-1). The pedestrian overlap will terminate even if the phase is halted in red transfer.

MM-2-3 Parameter	Description	Range
OVERLAP NUMBER – 1 thru 16	Use the cursor arrows (right, left, up, down) to position the cursor to the appropriate OVERLAP NUMBER and INCLUDED PHASES coordinates, then use Toggle, <b>O/YES</b> , include (X) or exclude (“.”) each pedestrian movement from the overlap.	“X” selects, “.” excludes.
INCLUDED FOR VEHICLE AND PED OVERLAPS	<p><b>Overlap Included Phases:</b></p> <p>The Included Phases specify the phases whose timing state will be used to derive the state of the overlap.</p> <p>In general terms, when any included phase is timing its green interval or the controller is advancing from one included phase to another included phase, the overlap will be green. If no included phase is green, then the overlap will be yellow when any included phase is yellow. If no included phase is green or yellow, the overlap will be red. The normal derivation of the overlap's state can be altered by using any of the programming options in MM-2-2.</p>	‘X’ selects



## Guaranteed Minimum Times, MM-2-4

Guaranteed minimum time for phase or overlap intervals. These entries establish the lower limit that the phase or overlap intervals must time.

**Note** • The circumstances that can cause guaranteed minimum times to be ignored include: Manual advance input, Preemptor timing, and External Start input.

GUARANTEED MINIMUM TIME DATA								
PHASE	A01	B02	C03	D04	E05	F06	G07	H08
MIN GRN	5	5	5	5	5	5	5	5
WALK	0	0	0	0	0	0	0	0
PED CLR	7	7	7	7	7	7	7	7
YELLOW	3.0	3.0	3.0	3.0	3.0	3.0	3.0	3.0
RED CLR	0.0	0.0	0.0	0.0	0.0	0.0	0.0	0.0
OVL GRN	5	5	5	5	5	5	5	5
PHASE	I09	J10	K11	L12	M13	N14	O15	P16
MIN GRN	5	5	5	5	5	5	5	5
WALK	0	0	0	0	0	0	0	0
PED CLR	7	7	7	7	7	7	7	7
YELLOW	3.0	3.0	3.0	3.0	3.0	3.0	3.0	3.0
RED CLR	0.0	0.0	0.0	0.0	0.0	0.0	0.0	0.0
OVL GRN	5	5	5	5	5	5	5	5

MM-2-4 Parameter	Description	Range
MIN GRN	<p><b>Guaranteed Minimum Green:</b> The shortest possible vehicle green time, before any added initial or vehicle extensions.</p> <p><b>Note</b> • Actual minimum green time will be the longest of the following: minimum green plus any added initial, vehicle extension, bike minimum green, ped walk plus ped clearance and guaranteed minimum green.</p>	0-255 sec.
WALK	<p><b>Guaranteed Pedestrian Walk:</b> The shortest possible pedestrian walk time.</p> <p><b>Note</b> • Actual minimum walk time will be the longer of the Walk time in effect or guaranteed* walk.</p>	0-255 sec.
PED CLR	<p><b>Guaranteed Pedestrian Clearance:</b> The shortest possible pedestrian clearance time.</p> <p><b>Note</b> • Actual minimum pedestrian clearance time will be the longer of the Pedestrian Clearance in effect or guaranteed* pedestrian clearance.</p>	0-255 sec.
YELLOW	<p><b>Guaranteed Yellow Change:</b> The shortest possible phase yellow indication following a green interval.</p> <p><b>Note</b> • Actual minimum yellow change time will be the longer of the Yellow time or guaranteed* yellow.</p>	0-25.5 sec.

▪ Start/Flash Data, MM-2-5

MM-2-4 Parameter	Description	Range
RED CLR	<p><b>Guaranteed Red Clearance:</b> The shortest possible red indication following a yellow change interval when terminating the phase.</p> <p><b>Note</b> • Actual minimum red clearance time will be the longer of the Red Clearance time in effect or guaranteed* red clearance.</p>	0-25.5 sec.
OVL GRN	<p><b>Guaranteed Overlap Green:</b> Minimum overlap green that must be timed before the overlap is allowed to terminate.</p> <p><b>Note</b> • If an overlap's guaranteed green has not been satisfied by the time the overlap initiating included phase is ready to terminate its green interval, the phase's green interval is extended until the overlap guaranteed green has been timed.</p>	0-255 sec.

\* Circumstances that can alter this minimum time include: Manual Advance input, Preemptor timing, and External Start input.

Start/Flash Data, MM-2-5

```

START/FLASH DATA
-----START UP-----
          1 2 3 4 5 6 7 8 9 0 1 2 3 4 5 6
PHASE    R R R R R R R R R R R R R R R R
          A B C D E F G H I J K L M N O P
OVERLAP  X X X X . . . . . . . . . .
FLASH>MON. NO FL TIME..255 ALL RED... 6
PWR START SEQ.. 1 MUTCD->YES Y->G: NO
-----AUTOMATIC FLASH-----
          PHASE 1 2 3 4 5 6 7 8 9 0 1 2 3 4 5 6
ENTRY    . X . . . X . . . . . . . . . .
EXIT     . X . . . X . . . . . . . . . .
OVERLAP  A B C D E F G H I J K L M N O P
EXIT     X X X X . . . . . . . . . .
FLASH>MON. NO EXIT FL. W MIN FLASH. 8
MINIMUM RECALL. NO CYCLE THRU PHASE. NO
    
```

The Start/Flash Data screen (MM-2-5) is divided into Start Up and Automatic Flash sections.

In the Start Up section, the phase and overlaps selections, type of flash, power start red time, and power on flash time are specified.

The Automatic Flash includes Auto Flash, Remote Flash, system flash, programmed flash, and TBC flash.

The Automatic Flash section provides for the selection of entry phases and exit phases and overlaps, a minimum flash time, type of flash, and the enabling of options used during automatic flash.

## Start Up Programming

The Power Start-Up Phases begin timing after the flash and power start red times have been satisfied or after an external start input.

### To program Start Up:

- 1 Use Toggle, **0/YES**, to select the start phases and their start interval. Only one phase selection is allowed for each ring and it must not conflict with any other ring phase selections.
- 2 Enter the Power Start all Red time. This interval times after flash time. Zero entry disables the all red timing function.
- 3 Enter the Power Start Flash Time. This interval times before all red time. Zero entry disables the controller flash timing function.
- 4 Select the type of Flash via FLASH>MON to select flashing either through the Controller Voltage Monitor (CVM) or Load Switches.

### To program Automatic Flash:

- 1 Select the last non-conflicting active phase(s) that are to be timed before entry to automatic flash.
- 2 Select non-conflicting phase(s) that are to be active when automatic flash is exited.
- 3 Select overlap(s) that will be active when exiting automatic flash. The overlap(s) follow the normal overlap programming. This programming has no effect on the normal overlap operation except when exiting automatic flash.
- 4 Select “Flash through Load Switches” option (NTCIP standard is “X”).
- 5 Select “Minimum Recall” option to apply min recall to all phases when automatic flash is requested.
- 6 Select “Cycle through Phase” option to allow cycling of all intervening phases when going into automatic flash. When both Minimum recall and “Cycle through Phases” are selected, the controller will time every phase for the minimum green time before entering automatic flash.
- 7 Select the minimum automatic flash time. The controller will not exit automatic flash until this time has expired.
- 8 Select the type of Flash via FLASH>MON to select flashing either through the Controller Voltage Monitor (CVM) or Load Switches.
- 9 Select the Exit Automatic Flash interval.

- Start/Flash Data, MM-2-5

MM-2-5 Parameter	Description	Range
<b>Start Up</b>		
PHASE	<p><b>Power Start Phase Interval</b></p> <p>Phase(s) and intervals selected to begin timing when controller power is first applied to the controller after an interruption greater than 0.6 seconds, or an external start input is applied.</p> <p>. : Indicates the phase indication is red and the phase is not timing.</p> <p><b>G:</b> The phase indication is green without walk and MIN GRN is timing.</p> <p><b>W:</b> The phase indication is green with walk and WALK is timing.</p> <p><b>Y:</b> The phase indication is yellow and YELLOW CHANGE is timing.</p> <p><b>R:</b> The phase indication is red and RED CLEARANCE is timing.</p> <p><b>Note</b> • If no phase is programmed (All phases programmed "."), the controller will start in the first phase in ring one and the first phase in each ring that is compatible with it.</p>	G, W, Y, R enables phase and interval. "." disables phase
START UP OVERLAP	<p><b>Power Start Overlaps</b></p> <p><b>X:</b> Enable overlaps that will be:</p> <ul style="list-style-type: none"> <li>■ Green if it would normally be green during the Power Start phase indication.</li> <li>■ Yellow if it would normally have been yellow during the Power Start phase indication.</li> <li>■ Red if it would normally have been red during the Power Start phase indication.</li> </ul> <p>. : Disables the overlap during power start. The overlap will start in Red and follow the overlap programming when the next phase starts timing.</p>	'X' enables
FLASH>MON	<p><b>Flash through CVM or through Load Switches (at Power Start Up)</b></p> <p>Power Start-up flash type.</p> <p><b>YES:</b> Power Start Flash through Controller Voltage Monitor (CVM)</p> <p><b>NO:</b> Power Start Flash through Load Switches</p>	YES, NO

MM-2-5 Parameter	Description	Range
FL TIME	<p><b>Power Start Flash Time</b></p> <p>Time during which all phases are in Flash at power start following a power interruption greater than 750 plus or minus 250 milliseconds. If START FLASH time is non-zero, the Controller sets all outputs FALSE for 2 seconds prior to timing START FLASH period.</p> <p><b>Note</b> • If the intersection cabinet is equipped with a MMU or CMU that latches Fault Monitor (FM) or Controller Voltage Monitor (CVM), the monitor power-on flash time must be set to nine seconds or larger.</p> <p><b>Note</b> • FLASH interval times first when both RED and FLASH times are entered. If FLASH timing is non-zero, the controller sets all outputs FALSE for 2 seconds prior to timing the FLASH period.</p>	0-255 sec.
ALL RED	<p><b>All Red Interval Time After Flash</b></p> <p>Time during which all phases are red after a flash condition except preempt flash.</p> <p><b>Note</b> • [MUTCD = Manual on Uniform Traffic Control Devices.] MUTCD 2009 requires the controller to exit red/red-flash to a minimum of 6 seconds of all red. To meet the MUTCD requirement, you must set this parameter to 6 seconds or greater. The MUTCD default time is 6 seconds. This function was mandatory as of December 2013, although many agencies required it before that date.</p> <p><b>Note</b> • If the intersection cabinet is equipped with an MMU or CMU that latches Fault Monitor (FM) or Controller Voltage Monitor (CVM), the monitor power-on flash time must be set to nine seconds or larger.</p>	0-255 sec.

- Start/Flash Data, MM-2-5

MM-2-5 Parameter	Description	Range
PWR START SEQ	<p><b>Power Start Sequence</b></p> <p><b>1-16:</b> Selects one of 16 possible configurations of sequence data (refer to NTCIP 1202 2.5.7.5 and NTCIP 1202 2.8.3.3). If “?” is displayed, the database contains a zero (0), which is converted to 1.</p> <p><b>17-20:</b> Selects one of 4 pre-programmed controllers, each with one pre-programmed sequence. For diamond intersection application notes, refer to Appendix Q, <i>Diamond Intersection Application Notes</i>.</p> <ul style="list-style-type: none"> <li>■ 17 = Diamond 4-Phase controller.</li> <li>■ 18 = Diamond 3-Phase controller.</li> <li>■ 19 = Diamond NEMA controller (8-phase Standard Quad).</li> <li>■ 20 = Diamond Separate Intersection controller.</li> </ul> <p><b>Note</b> • This entry will be overwritten by SYSTEM, COORDINATION, TIMEBASE inputs, or by HARDWARE inputs if HARDWARE ALTERNATE SEQUENCE ENABLE is YES on MM-1-1-1 (which results in sequence number 1 if the alternate sequence input bits are zero).</p>	<p>1-16 or 17-20</p>

MM-2-5 Parameter	Description	Range
MUTCD - >	<p><b>MUTCD = Manual on Uniform Traffic Control Devices</b></p> <p><b>No:</b> Econolite Flash Operation that affects Startup, Automatic and Preempt Flash operations.</p> <p><b>Yes:</b> MUTCD-2009 Flash Operation that affects Startup, Automatic and Preempt Flash operations.</p> <p>MUTCD Operation specifies these phase sequences for the respective initial flashing color:</p> <p><b>Flashing Red</b></p> <ol style="list-style-type: none"> <li><b>1</b> Flashing Red</li> <li><b>2</b> Solid Red (all phases)</li> <li><b>3</b> Start Phases</li> </ol> <p><b>Flashing Yellow</b></p> <ol style="list-style-type: none"> <li><b>1</b> Flashing Yellow</li> <li><b>2</b> Solid Yellow (same phase as Flashing Yellow)</li> <li><b>3</b> Solid Red (all phases)</li> <li><b>4</b> Start Phases</li> </ol> <p><b>Flashing Yellow</b> (when <b>Y-&gt;G</b>, yellow to solid green mode, in this screen is set to <b>Yes</b>)</p> <ol style="list-style-type: none"> <li><b>1</b> Flashing Yellow</li> <li><b>2</b> Solid Green (same phase as the Flashing Yellow)</li> </ol> <p><b>Programming that is affected by this parameter:</b></p> <ul style="list-style-type: none"> <li>■ Startup Flash and Automatic Flash</li> <li>■ Startup Flash All Red time, 6 sec default</li> <li>■ Startup Flash Phases (Yellow is not allowed)</li> <li>■ Automatic Flash Exit Color (Yellow is not allowed)</li> </ul> <p>Consistency Checks have been added to prevent database entries that would allow incorrect MUTCD operation.</p>	<p>NO, disable</p> <p>YES, enable</p>

- Start/Flash Data, MM-2-5

MM-2-5 Parameter	Description	Range
MUTCD-> (cont.)	<p><b>External Start application:</b></p> <ul style="list-style-type: none"> <li>■ In general, applying External Start will force the controller to its All Red Startup state and wait until External Start is released.</li> <li>■ However, applying External Start during Preempt will first force the controller to Fault Flash state which drops CVM. Fault Flash will continue until External Start and All Preempt inputs are removed, at which point the controller will time its All Red Startup state and then start its programmed start phases.</li> <li>■ When External Start is applied during Startup Flash, the controller will complete the flash time and then wait in MUTCD Red until External Start is released.</li> </ul>	NO, disable  YES, enable
Y->G	<p><b>MUTCD Yellow to Green</b></p> <p><b>Note</b> • For this parameter to operate, MUTCD-&gt; (the MUTCD 2009 parameter) in this screen must be enabled (set to Yes); if not, this parameter is hidden.</p> <p>Refer to the detailed explanation of this in the MUTCD 2009 description above.</p> <p><b>Yes</b> = Enables MUTCD 2009 Yellow &gt; Green for Flashing Yellow</p> <p><b>No</b> = Disables MUTCD 2009 Yellow &gt; Green for Flashing Yellow</p>	NO, disable  YES, enable
<b>Automatic Flash</b>		
AUTOMATIC FLASH PHASE ENTRY	<p><b>Entry into Automatic Flash Phase(s)</b></p> <p>Phase(s) active last before flash. The phase controller enters and times minimum green, yellow, and red clearance before initiating automatic flash.</p> <p><b>Note</b> • All overlaps will terminate normally to all red with the automatic flash entry phases.</p>	'X' enables



MM-2-5 Parameter	Description	Range
AUTOMATIC FLASH PHASE EXIT	<p><b>Exit Automatic Flash Phase(s) and Indications</b></p> <p>Phases and indications that the controller times first when exiting automatic flash</p> <ul style="list-style-type: none"> <li>• : Indicates the phase indication is red and the phase is not timing.</li> </ul> <p><b>G:</b> The phase indication is green without walk and MIN GRN is timing.</p> <p><b>W:</b> The phase indication is green with walk and WALK is timing.</p> <p><b>Y:</b> The phase indication is yellow and YELLOW CHANGE is timing.</p> <p><b>R:</b> The phase indication is red and RED CLEARANCE is timing.</p> <p><b>Note • If no phase is programmed (All phases programmed “.”), the controller will start in the first phase in ring one and the first phase in each ring that is compatible with it.</b></p>	G, W, Y, R enables phase and interval. “.” disables phase
AUTOMATIC FLASH OVERLAP EXIT	<p><b>Exit Automatic Flash Overlap(s) and Indications</b></p> <p><b>X:</b> The overlap indication will be:</p> <ul style="list-style-type: none"> <li>■ Green if it would normally be green during the exit automatic flash phase indication.</li> <li>■ Yellow if it would normally have been during the exit automatic flash phase indication.</li> <li>■ Red if it would normally have been red during the exit automatic flash phase indication.</li> </ul> <ul style="list-style-type: none"> <li>• : The overlap will be start in Red and follow the overlap programming when the next phase starts timing.</li> </ul>	‘X’ enables
FLASH>MON	<p><b>Flash through CVM or through Load Switches (at Automatic Flash)</b></p> <p>Automatic Flash type.</p> <p><b>YES:</b> Power Start Flash through Controller Voltage Monitor (CVM)</p> <p><b>NO:</b> Power Start Flash through Load Switches</p>	YES, NO

▪ Start/Flash Data, MM-2-5

MM-2-5 Parameter	Description	Range
EXIT FL	<p><b>Remote / Automatic Flash Exit Interval</b></p> <p>Range: G, W, Y, R</p> <p>G, Y, R (ECPI Features)</p> <p>W NEMA TS2 3.9.1.2.1</p> <p>W NTCIP 1202 2.2.2.21 BIT 2</p> <p>TOGGLE to enable interval that the phase will start in when exiting remote (automatic) flash.</p> <p><b>G:</b> The phase indication is green without walk and MIN GRN is timing. (This is an ECPI Feature.)</p> <p><b>W:</b> The phase indication is green with walk and WALK is timing. If there is no walk time programmed, the phase will start in MIN GREEN. (This is a NEMA TS2 and NTCIP requirement.)</p> <p><b>Y:</b> The phase indication is yellow and YELLOW CHANGE is timing. (This is an ECPI Feature.)</p> <p><b>R:</b> The phase indication is red and RED CLEARANCE is timing. (This is an ECPI Feature.)</p>	G, W, Y, R
MIN FLASH	<p><b>Minimum Automatic Flash Time</b></p> <p><b>0 – 255:</b> Enter the minimum time, in seconds, that the controller must remain in Automatic or automatic flash before it is allowed to exit.</p>	0-255 Seconds

MM-2-5 Parameter	Description	Range
MINIMUM RECALL	<p><b>Minimum Recall</b></p> <p><b>X:</b> Enables, allows the controller to cycle through the active phase(s), applying only the minimum green to each phase until the automatic flash entry phase(s) is reached and then going into automatic flash.</p> <p><b>.</b> : Disables and the controller does not apply minimum vehicle recall while automatic or automatic flash is requested.</p> <p><b>Note</b> • When enabled and cycle through phases is enabled, the controller will service every phase for a minimum time and then advance to the automatic flash entry phases.</p>	'X' enables
CYCLE THRU PHASE	<p><b>Cycle Through Phases</b></p> <p><b>X:</b> Enables, allowing the controller to service phases with a demand that are between the active phase(s) and automatic flash entry phase(s).</p> <p><b>.</b> : Disables and the controller goes directly to the automatic flash entry phase(s).</p> <p><b>Note</b> • When enabled and minimum recall is enabled, the controller will service every phase for a minimum time and then advance to the automatic flash entry phases.</p>	X enables . disables



MM-2-6-1 Parameter	Description	Range
UNIT RED REVERT	<p><b>Unit Red Revert</b></p> <p>Provides the minimum red revert time for every phase. The actual red revert time for any phase will be the larger of this and the phase Red Revert time (MM-2-1).</p> <p><b>Note</b> • Red Revert is the minimum phase red indication to be timed after the yellow change interval before a phase can once again display green. The greater of the Unit Red Revert or the phase's Red Revert is timed.</p> <p><b>IMPORTANT</b> • NEMA mandates minimum limit time setting at 2 seconds. NTCIP allows for this value to be set lower.</p>	0.0-25.5 sec.
MUTCD 3 SECONDS DONT WALK	<p><b>MUTCD 3 Seconds DONT WALK</b></p> <p>This conforms to MUTCD 2009, Section 4E.06, Pedestrian Intervals and Signal Phases, Paragraph 04, that states:</p> <p>Following the pedestrian change interval, a buffer interval consisting of a steady UPRAISED HAND (symbolizing DONT WALK) signal indication shall be displayed for at least 3 seconds prior to the release of any conflicting vehicular movement.</p> <p><b>No:</b> If Ped protected overlap is enabled, after serving an included protected phase pedestrian demand, it starts the overlap if there is enough time before maxout to service the overlap minimum green.</p> <p><b>Yes:</b> If Ped protected overlap is enabled, after serving an included protected phase pedestrian demand, stays in DONT WALK for 3 seconds and then starts the overlap if there is enough time before maxout to service the overlap minimum green.</p>	YES enables NO disables

MM-2-6-1 Parameter	Description	Range
FLASHING GRN PH	<p><b>Flashing Green Phase</b></p> <p>Range: ., F1, F2, F5</p> <p>This is an ECPI Feature (applies to TS1 and TS2 operation). TOGGLE to select F1, F2 or F5.</p> <p>Select Phase Green SOLID or FLASHING operation:</p> <p>.: The Phase Green is solid during service (no flash).</p> <p><b>F1:</b> The Phase Green is Flashed at 1 PPS during service.</p> <p><b>F2:</b> The Phase Green is Flashed at 2 PPS during service.</p> <p><b>F5:</b> The Phase Green is Flashed at 5 PPS during service.</p> <p>Use this Flashing Green Phase option to easily select the phases and their respective flashing rates (there is no need to use the Logic Processor).</p> <p><b>Note</b> • This setting does <i>not</i> affect Preempt TRACK and DWELL phase selection. Preempt programming has separate data entries to flash phases while in TRACK and DWELL intervals. However, the CYCLE phases are the same as those programmed here.</p>	F1, F2, F5, “.” disables
GUAR PASSAGE	<p><b>Guaranteed Passage</b></p> <p>Position the cursor at the desired column and row and use Toggle, <b>O/YES</b>, to enable (X) or disable (“.”) the phase for Guaranteed Passage.</p> <p>If a phase’s vehicle extension times out while timing a reduced vehicle extension and guaranteed passage is selected, the difference between the reduced interval and the initial vehicle extension is timed before a vehicle extension time out is reported. This option guarantees the timing of a full vehicle extension for the last detected vehicle.</p>	X enables “.” disables
NON-ACT I NON-ACT II	<p><b>Call-to-Non-Actuated (CNA) Mode Inputs I and II</b></p> <p>Position the cursor at the desired column and row and use Toggle, <b>O/YES</b>, to enable (X) or disable (“.”) Non-Actuated service for the phase.</p> <p>CNA I and II mode inputs are used to enable and disable the NON-ACT I and NON-ACT II settings. In Dual Coordination, the phases programmed as call-to-nonactuated II are the crossing artery phases.</p> <p><b>Note</b> • Non-actuated phases normally have pedestrian time settings.</p>	X enables “.” disables

MM-2-6-1 Parameter	Description	Range
DUAL ENTRY	<p><b>Dual Entry</b></p> <p>Position the cursor at the desired column and row and use Toggle, <b>O/YES</b>, to enable (X) or disable (“.”) a phase’s Dual Entry assignment.</p> <p>Dual entry is a mode of operation in which one phase in each ring must be in operation. If there is no call on a ring when the controller crosses a barrier, a call is automatically placed on a compatible dual entry phase in that ring.</p> <p><b>Note</b> • <b>Dual Entry processing includes actively delayed detectors as a serviceable call. The controller does <u>not</u> skip a phase that has an active but delayed detector. A Delayed Detector (with a DELAY TIME in MM-6-2) is serviced when this Dual Entry is enabled.</b></p>	<p>X enables “.” disables</p>
COND SERVICE	<p><b>Conditional Service</b></p> <p>This allows the order of service to be modified. It permits an actuated preceding phase in the same ring as the specified phase to be timed if it has a call and is compatible with the phases timing in the other rings. Such timing is only allowed when a cross ring phase not ready to terminate is timing max green and the time remaining until max out is greater than or equal to time required to transition to the preceding phase and time its conditional service minimum green.</p>	<p>X enables conditional service from an actuated phase “.” disables conditional service for a phase</p>
COND RESERVICE	<p><b>Conditional Reservice</b></p> <p>This allows conditional service phases to be reserviced after a ring phase that precedes it has been conditionally serviced and is ready to terminate. Such timing is only allowed when a cross ring phase not ready to terminate is timing max green and the time remaining until max out is greater than or equal to time required to transition back to the conditional service phase and time its conditional service minimum green.</p>	<p>X Enables conditional reservice for an actuated phase that is also enabled for conditional service. “.”Disables conditional reservice for a phase.</p>

- Option Data, MM-2-6

MM-2-6-1 Parameter	Description	Range
PED RESERVICE	<p><b>Pedestrian Re-service</b></p> <p>Position the cursor at the desired column and row and use Toggle, <b>O/YES</b>, to enable (X) or disable (“.”) the phase for Pedestrian Re-service.</p> <p>This option enables the phase’s pedestrian movement to be serviced or re-serviced any time if there is adequate time for its walk and pedestrian clearance intervals to be completed before a Max out or coordinated force off. If re-service is enabled for a pedestrian service that is already in walk or pedestrian clearance when a call for service is input, the pedestrian movement returns to start of walk.</p>	X enables “.”disables
REST IN WALK	<p><b>Actuated Rest in Walk</b></p> <p>Position the cursor at the desired column and row and use Toggle, <b>O/YES</b>, to enable (X) or disable (“.”) the Actuated Rest In Walk option for a phase’s pedestrian service.</p> <p>Allows a phase with an actuated pedestrian call to rest at end of the pedestrian walk interval until a serviceable conflicting call is received.</p>	X enables “.”disables
FLASHING WALK	<p><b>Flashing Walk</b></p> <p>Position the cursor at the desired column and row and use Toggle, <b>O/YES</b>, to enable (X) or disable (“.”) the phase’s pedestrian service for flashing walk.</p> <p>Pedestrian walk output is turned on for half a second and then off for half a second. The ON and OFF flash is repeated for the duration of the walk interval.</p>	X enables “.”disables
PED CLR> YELLOW	<p><b>Pedestrian Clearance through Yellow Change</b></p> <p>Position the cursor at the desired column and row and use Toggle, <b>O/YES</b>, to enable (X) or disable (“.”) the phase’s pedestrian clearance interval from being extended to the end of the Yellow Change interval.</p> <p>Enables a phase pedestrian clearance indication to time through the yellow change interval. The pedestrian clearance time remains the same but the last portion is timed during the Yellow Change interval.</p>	X enables “.”disables



MM-2-6-1 Parameter	Description	Range
PED CLR>RED	<p><b>Pedestrian Clearance through Red Clearance</b></p> <p>Position the cursor at the desired column and row and use Toggle, <b>O/YES</b>, to enable (X) or disable (“.”) the phase’s pedestrian clearance interval from being extended to the end of the Red Clearance.</p> <p>Enables a phase pedestrian clearance indication to time through the Yellow Change and Red Clearance intervals. The pedestrian clearance time remains the same but the last portion is timed during the Yellow Change and Red Clearance intervals.</p>	X enables “.” disables
IGRN + VEH EXT	<p><b>Initial Green times then Vehicle Extension Starts</b></p> <p>Position the cursor at the desired column and row and use Toggle, <b>O/YES</b>, to enable (X) or disable (“.”) this phase timing option.</p> <p>This option requires a phase time in its initial green interval before starting vehicle extension timing. During normal operation, the initial green and vehicle extension intervals both begin timing at the start of the phase’s green interval.</p>	X enables “.” disables

### Extended Options, MM-2-6-2

This menu displays the Extended Logic Processor Groups described in asc3.ext file that is part of the Controller Database set. Refer to *Extended Logic Processor Group* on page 6-64 for more information

```

EXTENDED OPTIONS

NO CONFIGURABLE DATA

```

```

EXTENDED OPTIONS

IDOT 5 SECTION HEAD CONTROL.....ON
LP FEATURE.....OFF
CANADIAN LEFT TURN.....OFF

```

- Pre-Timed Mode, MM-2-7

### Pre-Timed Mode, MM-2-7

```
PRE-TIMED MODE
ENABLE PRE-TIMED MODE..... NO
FREE INPUT ENABLES PRE-TIMED..... YES
  PHASE 1 2 3 4 5 6 7 8 9 0 1 2 3 4 5 6
PRETIMED . . . . .
```

Provides “fixed time” capability on selected (X) phases. The phases not selected (“.”) will operate as programmed.

**To enable/disable Pre-Timed operation mode:**

- ▶ To enable, press toggle, **0/YES**, to select X.

**Or**

- ▶ To disable, press toggle, **0/YES**, to select “.”

**Fixed time means:**

The phase is placed on Max vehicle and pedestrian recall.

The Walk interval is expanded to make walk plus ped clearance equal to the phase max in effect time. If the programmed Walk plus Pedestrian Clearance intervals are longer than the max in effect time, the phase will time the programmed Walk and Pedestrian clearance.

Phases programmed as Rest in Walk (MM-2-6-1) are commanded to fixed time.

---

**Note • Pre-timed operation can be disabled by:**

- External input by mapping an input (MM-1-8-1)
  - Time Base
  - Logic Processor (MM-1-9) activating the “INHIBIT PRE-TIME” input.
- 

### Recall Data, MM-2-8

**Phase Recall Options**

Use this screen to select options for phases 1 thru 16 that include: Lock Detector, Vehicle Recall, Pedestrian Recall, Max Recall, Soft Recall, No Rest, and Added Initial Calculation. Display below is repeated for plans 2-4.

**To set options:**

- 1** Press **1..4** to set the Timing Plan Number value.
- 2** Use the cursor arrow keys (right, left, up, and down) to position the cursor at the appropriate option/phase location.

- 3 Use Toggle, **0/YES**, to an X (enable) or “.” (disable) the selected option for the selected phase.

Data in MM-2-1 and MM-2-8 are in the same plan and would execute together; so these two displays are hyperlinked together.

```

PHASE RECALL OPTIONS
TIMING PLAN NUMBER [ 1 ]
  PHASE.. 1 2 3 4 5 6 7 8 9 0 1 2 3 4 5 6
LOCK DET X X X X X X X X X X X X X X X X
VE RCALL . . . . .
PD RCALL . . . . .
MX RCALL . . . . .
SF RCALL . . . . .
NO REST . . . . .
AI CALC . . . . .
    
```

**When in a hyperlink field:**

**To follow the hyperlink:**

For ASC/3, press **SPEC FUNC**, then **NEXT DATA**.

For 2070, press **B**.

**To go back:**

For ASC/3, press **SUB MENU**.

For 2070, press **ESC**.

MM-2-8 Parameter	Description	Range
TIMING PLAN NUMBER	<b>Timing Plan Number</b> Use the numeric (0-9) keys to specify the timing plan (1-4) to view or edit. This has a hyperlink that links to MM-2-1, Timing Plan.	1-4
LOCK DET	<b>Phase Locking of Vehicle Detector</b> Toggle to enable (X) or disable (“.”) the phase locking of detector inputs.  When locking memory is enabled, an actuation on any detector input assigned to the associated phase during yellow or red is “remembered” as a vehicle call and is not reset when the vehicle call is no longer present. Reset occurs during green.  <b>Note</b> • Locking memory function can be assigned per detector for each detector associated with a phase. (MM-6-2).	X enables “.” disables
VE RCALL	<b>Phase Vehicle Recall</b> Toggle to enable (X) or disable (“.”) phase vehicle recall.  Vehicle recall places a demand for vehicle service on a phase by registering a call while the phase is not in the green interval.	X enables “.” disables

▪ Recall Data, MM-2-8

MM-2-8 Parameter	Description	Range
PD RCALL	<p><b>Phase Pedestrian Recall</b></p> <p>Toggle to enable (X) or disable (“.”) phase pedestrian recall.</p> <p>Pedestrian recall places a demand for pedestrian service on a phase by registering a call while the phase is not in the walk interval.</p>	<p>X enables “.” disables</p>
MX RCALL	<p><b>Phase Recall To Maximum Time</b></p> <p>Toggle to enable (X) or disable (“.”) recall to max.</p> <p>Places a continuous vehicle call on the phase.</p> <p>The phase times to the maximum green time.</p> <p>Maximum green timer begins timing as though an opposing call was present, but the phase does not terminate unless there is an actual opposing call.</p>	<p>X enables “.” disables</p>
SF RCALL	<p><b>Soft Recall (Rest in these Phases).</b></p> <p>Toggle to enable (X) or disable (“.”) soft recall.</p> <p>Soft recall places a call on these enabled phase(s) when the controller goes to rest in other phases.</p> <p><b>Note • Typical Soft Recall phases are through-phases such as 2 and 6.</b></p>	<p>X enables “.” disables</p>
NO REST	<p><b>Do Not Rest In These Phases</b></p> <p>Toggle to enable (X) or disable (“.”) phases that the controller may not rest in.</p> <p>Absence of detector calls, the controller automatically goes to the next phase that is allowed to rest.</p> <p><b>Note • Soft Recall overrides the No Rest entry.</b></p>	<p>X enables “.” disables</p>
AI CALC	<p><b>Added Initial Calculation by Phase</b></p> <p>Toggle to enable (X) or disable (“.”) the added initial calculation to include all detector inputs to the phase.</p> <p><b>Note • This overrides individual detector option (USE ADDED INITIAL, MM-6-2) where the added initial calculation includes only the most active detector.</b></p>	<p>X enables “.” disables</p>



---

## Coordinator

### Coordinator Submenu, MM-3

---

**Note** • The Coordination Phase Reservice services the phase in the same ring of its concurrent group.

---

#### *Programming Summary*

COORDINATOR SUBMENU

1. COORDINATOR OPTIONS
2. COORDINATOR PATTERNS
3. SPLIT PATTERNS
4. AUTO PERM MIN GREEN
5. SPLIT DEMAND

A brief description follows of the programming functions that you can view and/or change at each of the menu options.

▪ Programming Summary

MM-3 Menu Option	Programming Summary
1. COORDINATOR OPTIONS	<p>Accesses a data entry screen that you can use to specify 18 different coordinator option values as follows:</p> <ul style="list-style-type: none"> <li>■ Enable manual pattern.</li> <li>■ Select source of interconnect commands.</li> <li>■ Select format of interconnect commands.</li> <li>■ Select transition method.</li> <li>■ Enable ECPI coordination operations.</li> <li>■ Select offset reference point.</li> <li>■ Enter dwell/add time.</li> <li>■ Enable Walk delayed to Local Zero.</li> <li>■ Select floating or fixed force-off.</li> <li>■ Enable Force-off added initial green.</li> <li>■ Enable the use of pedestrian time in determining smooth transition direction.</li> <li>■ Enable pedestrian recall.</li> <li>■ Enable pedestrian re-service.</li> <li>■ Enable manual sync input.</li> <li>■ Enable local zero override.</li> <li>■ Enter re-sync count.</li> <li>■ Select max or inhibit during coordination.</li> <li>■ Enable multi-sync operation.</li> </ul>

MM-3 Menu Option	Programming Summary
2. COORDINATOR PATTERNS	<p>Accesses a data entry screen that includes 19 coordinator pattern data groups as follow:</p> <ul style="list-style-type: none"> <li>■ Enter cycle length.</li> <li>■ Select COS command</li> <li>■ Select split pattern.</li> <li>■ Enter offset value.</li> <li>■ Select controller sequence.</li> <li>■ Select split and offset timing in sec. or %.</li> <li>■ Select crossing artery pattern.</li> <li>■ Enter vehicle permissive periods 1 and 2.</li> <li>■ Enter vehicle permissive 2 displacement.</li> <li>■ Select a time-base action plan</li> <li>■ Enable actuated coordination.</li> <li>■ Select a timing plan.</li> <li>■ Enable actuated walk rest.</li> <li>■ Enable phase re-service.</li> <li>■ Select ring split extension value.</li> <li>■ Select split demand pattern.</li> <li>■ Enter ring displacement value.</li> <li>■ Enable directed split preference phases.</li> <li>■ Enable special function outputs.</li> </ul>
3. SPLIT PATTERNS	<p>Split pattern data has three data groups as follows:</p> <ul style="list-style-type: none"> <li>■ Select coordinated phases.</li> <li>■ Enter phase splits.</li> <li>■ Select mode for each phase.</li> </ul>
4. AUTO PERMISSIVE MINIMUM GREEN	<p>Enter auto permissive minimum green time.</p>
5. SPLIT DEMAND	<p>Split Demand data has four groups as follows:</p> <ul style="list-style-type: none"> <li>■ Select split demand phases.</li> <li>■ Select split demand detectors.</li> <li>■ Enter split demand call time.</li> <li>■ Enter split demand cycle count.</li> </ul>

- *Coordinator Options, MM-3-1*

### Source Priority

Priority Determination of the source of request:

ASC/3 treats all the 120 Coordinator patterns and 2 special patterns, Automatic Flash and Free, with the same priority. Pattern can be commanded by different sources, Manual, Remote, Internal, and Input.

**Priority of the source is as follows:**

- 1 Manual/Program Entry (MM-3-1 or MM-5-1) (Highest Priority)
- 2 Remote Command
  - a NTCIP (Through Coordinator pattern or Action plan command)
  - b ECPIP
- 3 Internal TOD MM-5-3 day plan scheduling MM-5-2 Action plan
- 4 Hardwire Input

## Coordinator Options, MM-3-1

### Programming Summary

```

COORD OPTIONS
MANUAL PATTERN... 1 ECPI COORD.....YES
SYSTEM SOURCE.. TBC SYSTEM FORMAT.. STD
SPLITS IN....SECONDS OFFSET IN...SECONDS
TRANSITION.. ADDONLY MAX SELECT. MAXINH
DWELL/ADD TIME... 0 ENABLE MAN SYNC. NO
DLY COORD WK-LZ.. NO FORCE OFF... FIXED
OFFSET REF.... LEAD CAL USE PED TM..YES
PED RECALL..... NO PED RESERVE..... NO
LOCAL ZERO OVRD.. NO FO ADD INI GRN.. NO
RE-SYNC COUNT.... 0 MULTISYNC..... NO
    
```

Use this screen to specify 20 different coordinator option values as follows:

MM-3-1 Parameter	Programming Summary
MANUAL PATTERN	Any non-zero entry selects that coordination pattern. If the pattern selected is not programmed correctly, coordinator is set to free.
ECPI COORD	Allows ECPI coordination operation and parameters
SYSTEM SOURCE	Move the indicated source option to the highest priority source for the coordination pattern.



MM-3-1 Parameter	Programming Summary
SYSTEM FORMAT	Determines the format in which the source is presenting the coordination pattern selection
SPLITS IN	Selects the split units as seconds or percent
OFFSET IN	Selects the offset units as seconds or percent
TRANSITION	Selects the method that the coordinator uses to get into coordination
MAX SELECT	Allow the maximum split time in coordination to be either the phase split or selected Max 1, 2, or 3.
DWELL OR ADD TIME	Enters the maximum time that the coordinator can dwell or add when transitioning
ENABLE MANUAL SYNCHRONIZATION	When a manual pattern is enabled and the Interconnect Source is TOD, the <b>CLEAR</b> key sets: <ul style="list-style-type: none"> <li>■ Local Master Dial to zero.</li> <li>■ Local dial to the offset value of the pattern.</li> <li>■ The internal sync reference point to the present time.</li> </ul>
DELAY COORDINATE PHASE WALK UNTIL LOCAL ZERO	Enable the coordinated phase walk to be prevented from starting until the local zero. Normally, the coordinated phase walk starts as soon as it is able to after the last permissive is closed.
FORCE OFF	Selects the method of determining the position of the phase force off
OFFSET REFERENCE	Selects the reference point for the programmed offset
CALCULATION USES PEDESTRIAN TIME	Allows the smooth transition algorithm to use or not to use the pedestrian times in determining the smooth transition direction
PED RECALL	Allows the programmed pedestrian recall (MM-6-3) to recycle the pedestrian movement when the Coordinator Pattern has Actuated Walk programmed
PED RE-SERVICE	Allows pedestrian movement when walk plus ped clearance can time before force-off point

▪ Programming Summary

MM-3-1 Parameter	Programming Summary
LOCAL ZERO OVERRIDE	<p>Allows the non-coordinated phase/s to use a portion of the coordinated phase split before the coordinated phase becomes green. The movement continues to run and remain in sync with the Local Master Dial until the coordinated phase would violate the Yield point. At that time, the Local Dial stops until the coordinated phase is green and reports a local zero error.</p> <p><b>Note</b> • Typically used on short cycles that have seldom used non-coordinated movements.</p>
FORCE OFF ADDED INITIAL GREEN	<p>Allows the coordinator to terminate the phase green when added initial is timing. This only has an effect when added initial is programmed during volume-density operation (MM-2-1).</p>
RE-SYNC COUNT	<p>Selects the number of missed syncs allowed from an external source before reverting to time-base.</p>
MULTISYNC	<p>Allows the coordinator to receive multiple sync pulses. The coordinator will synchronize to the pulse that represents cycle in effect.</p>

MM-3-1 Parameter	Description	Range
MANUAL PATTERN	<p><b>Manual Pattern Selection</b></p> <p><b>0:</b> Selects automatic selection of coordination pattern, free, or flash by other sources.</p> <p><b>1-120:</b> Selects that pattern for coordination operation. This selection overrides all other pattern selections.</p> <p><b>254:</b> Selects free operation and overrides any pattern or flash from any other source other than preemption. Sequence defaults to 1 if not specified.</p> <p><b>255:</b> Selects flash operation and overrides any coordination pattern or free from any other source.</p> <p>AUTOMATIC FLASH pattern is treated in the same priority as any other pattern.</p> <p><b>Note</b> • Manual Pattern selection overrides any other source. Manual Pattern overrides Manual Action plan (MM-5-1).</p>	0-120, 254, or 255

MM-3-1 Parameter	Description	Range
ECPI COORD	<p>Toggle to enable (YES) or disable (NO).</p> <p><b>YES:</b> The coordinator will:</p> <ul style="list-style-type: none"> <li>■ Not be set free if the critical phase (Minimum time to service the phase) time is greater than the split.</li> <li>■ Not be set free if the critical path (Minimum time to service all phases with minimum recall applied) through the phase diagram is greater than the cycle length.</li> <li>■ Will time 20 seconds of dwell with zero programmed in the DWELL / ADD time parameter.</li> <li>■ Will time the Smooth transitions add time if the DWELL / ADD time is greater than zero. If equal to zero, it will time 17%.</li> </ul> <p>Toggle to enable (YES) or disable (NO).</p> <p><b>NO (default):</b> The coordinator will:</p> <ul style="list-style-type: none"> <li>■ Be set free if the critical phase (Minimum time to service the phase) time is greater than the split (Reference NTCIP 1202-2.5.9.3).</li> <li>■ Be set free if the critical path (Minimum time to service all phases with minimum recall applied) through the phase diagram is greater than the cycle length (Reference NTCIP 1202-2.5.9.3).</li> <li>■ Will time max dwell regardless of what is programmed in the DWELL / ADD time parameter (Reference NTCIP 1202-2.5.2).</li> <li>■ Will time the Smooth transitions add time if the DWELL / ADD time is greater than zero. If equal to zero, it will time 17% (Reference NTCIP 1202-2.5.2).</li> <li>■ Force the coordinator to MAX INHIBIT when MAX SELECT is set to MAX3.</li> <li>■ Force the coordinator free when the Cycle is greater than 255.</li> </ul>	YES, NO

▪ Programming Summary

MM-3-1 Parameter	Description	Range
SYSTEM SOURCE	<p><b>System (Coordination) Source</b></p> <p>Press Toggle, <b>0/YES</b>, to select HDW, TBC or SYS as the source of coordination commands.</p> <p>Default source priority (Manual-Highest): Manual, Remote Command, TBC, hardwire. Selecting the below option to place it at the top priority source of coordination. All other sources will stay with default priority order.</p> <p><b>HDW:</b> The source of coordination data is the NEMA TS2 inputs.</p> <p><b>TBC:</b> The source of coordination data is Time Base.</p> <p><b>SYS:</b> The source of coordination data is Port 2/C50S, Port 3A/C21S or Port 3B/C22S depending on the GLOBAL PORT PARAMETERS (MM-1-5-1) programming.</p>	HDW, TBC, or SYS
SYSTEM FORMAT	<p><b>System (Coordination) Format</b></p> <p>Use Toggle, <b>0/YES</b>, to select STD, TS2 or PTN interconnect format.</p> <p><b>STD:</b> The coordination patterns are selected by Econolite-Standard cycle/offset/split commands. The pattern with the matched COS value is selected.</p> <p>The coordinator is free if the cycle or split is zero.</p> <p><b>TS2:</b> The coordination patterns are selected by TS2 timing plans and offset. The pattern selected is determined by the following:  <math display="block">(((\text{Timing plan}) * 3) + \text{offset}) = \text{pattern number.}</math>                     (Reference NEMA TS2 Table 3-14 "TIMING PLAN").</p> <p>The coordinator is free if the offset is zero. Flash is by a separate command.</p> <p><b>PTN:</b> The coordination pattern is selected directly by number.</p> <p><b>1-120:</b> Selects the coordination pattern</p> <p><b>254:</b> Sets the coordinator free</p> <p><b>255:</b> Commands automatic flash</p>	STD, TS2 or PTN

MM-3-1 Parameter	Description	Range
SPLITS IN	<p><b>Split Units</b></p> <p>SECONDS            NTCIP 1202 2.5.9.3</p> <p>PERCENT            (ECPI feature)</p> <p>Use Toggle, <b>0/YES</b>, to select SECONDS or PERCENT.</p> <p><b>SECONDS:</b> Defines the units programmed in the Split Pattern (MM-3-3) as seconds.</p> <p><b>PERCENT:</b> Defines the units programmed in the Split Pattern (MM-3-3) as percentage of the cycle time.</p> <p><b>Note</b> • When this parameter is changed between <b>SECONDS</b> and <b>PERCENT</b> on any coordination pattern, every pattern is changed.</p>	SECONDS, PERCENT
OFFSET IN	<p><b>Offset Units</b></p> <p>SECONDS            NTCIP 1202 2.5.7.3</p> <p>PERCENT            (ECPI feature)</p> <p>Use Toggle, <b>0/YES</b>, to select SECONDS or PERCENT.</p> <p><b>SECONDS:</b> Defines the units programmed in the OFFSET VAL (MM-3-2) as seconds.</p> <p><b>PERCENT:</b> Defines the units programmed in the OFFSET VAL (MM-3-2) as percentage of the cycle time.</p> <p><b>Note</b> • When this parameter is changed between <b>SECONDS</b> and <b>PERCENT</b> on any coordination pattern, every pattern is changed.</p>	SECONDS/ PERCENT

▪ Programming Summary

MM-3-1 Parameter	Description	Range
TRANSITION	<p>Use Toggle, <b>0/YES</b>, to select SMOOTH, ADD ONLY or DWELL to select the method of offset change.</p> <p><b>SMOOTH:</b> Is accomplished by adding or subtracting a maximum of 17% of cycle length per cycle (Ref NTCIP 1202 2.5.2 Integer 3). Econolite lets you change this factor by changing the “DWELL / ADD TIME” when it is non-zero.</p> <p><b>ADD ONLY:</b> Is accomplished by adding a maximum of 17% of cycle length per cycle (ref NTCIP 1202 2.5.2 Integer 4). Econolite lets you change this factor by changing the “DWELL / ADD TIME” when it is non-zero.</p> <p><b>DWELL:</b> Change is by holding in the coordinated phases for a specified dwell period (refer to NTCIP 1202 2.5.2 Integer 1).</p> <p>Snap offset correction is active at all times. The general operation performs as follows: “If a local cycle can be in sync, make it in sync.”</p>	SMOOTH, ADD ONLY or DWELL
MAX SELECT	<p>Press Toggle, <b>0/YES</b>, to select MAXINH, MAX 1, MAX 2 or MAX 3.</p> <p><b>MAXINH:</b> Allows the coordinator phase split to control the time a phase is allowed to be green in any Coordination Pattern.</p> <p><b>MAX 1, MAX 2 or MAX 3:</b> Allows the shorter of the MAX timing (MM-2-1) or the coordinator phase split to control the time a phase is allowed to be green in any Coordination Pattern.</p>	MAXINH, MAX 1, MAX 2, MAX 3

MM-3-1 Parameter	Description	Range
DWELL/ADD TIME	<p>Use the numeric keys (0-9) to enter the maximum time that Dwell or Add/Subtract time during transition.</p> <p>When the Offset Correction is Dwell:</p> <p><b>0 (zero):</b> NTCIP maximum dwell period (ref NTCIP 1202 2.5.2 Integer 2) is 20% of the cycle (if the offset is in percent) or 20 seconds (if the offset is in seconds).</p> <p><b>1-99:</b> Percentage if the offset is in percent</p> <p><b>100-255:</b> Seconds if the offset is in seconds</p> <p>When the Offset Correction is Add Only or Smooth Transition:</p> <p><b>0 (zero):</b> During add only or Smooth Transition, maximum 17% of the cycle to be adjusted (ref NTCIP 1202 2.5.2 Integers 3 and 4)</p> <p><b>1-99:</b> Maximum percentage of the cycle to be adjusted during Add Only or Smooth Transition</p> <p><b>Note • During Smooth Transition, the coordinator subtracts a maximum of 17% of the cycle.</b></p>	<p>0-255 seconds</p> <p>1-99 percent</p>
ENABLE MAN SYNC	<p><b>Enable Manual Coordination Synchronization</b></p> <p>Press Toggle, <b>0/YES</b>, to enable (X) or disable (“.”) manual synchronization of the coordinator during manual pattern selection when Manual Pattern is enabled.</p> <p><b>X:</b> Enables the <b>CLEAR</b> key to set:</p> <ul style="list-style-type: none"> <li>■ Local Master Dial to zero.</li> <li>■ Local dial to the offset value of the pattern before zero.</li> <li>■ The internal sync reference point to the present time. This allows the local dial to continue cycling without transition until manual operation ceases.</li> </ul> <p>“.”: Disables manual synchronization</p> <p><b>Note • Any power interruption will disrupt manual coordination. This feature is not saved in the DB.</b></p>	<p>X enable</p> <p>“.” disable</p>

▪ Programming Summary

MM-3-1 Parameter	Description	Range
DLY COORD WK-LZ	<p><b>Delay the Coordinated Walk to Local Zero</b></p> <p>Press Toggle, <b>0/YES</b>, to enable (YES) or disable (NO) delaying the start of the coordinated phase walks.</p> <p><b>YES:</b> Delays the start of walk of the coordinated phases until the start of local zero.</p> <p><b>NO:</b> Allows the coordinated phase walk to start after the end of the last permissive period is closed.</p>	YES, NO
FORCE OFF	<p><b>Determines position of the phase force off</b></p> <p><b>FIXED:</b> The phase will force off at the fixed position in the cycle regardless of when it started.</p> <p><b>FLOAT:</b> The phase will force off after it has serviced its split regardless of when it started.</p>	FIXED, FLOAT
OFFSET REF	<p><b>Offset Reference</b></p> <p>Press Toggle, <b>0/YES</b>, to select LEAD, LAG, YIELD, or YELLOW as the offset reference.</p> <p><b>LEAD:</b> References the start of the Local Dial to the start of the first coordinated phase green.</p> <p><b>LAG:</b> References the start of the Local Dial to the start of the last coordinated phase green.</p> <p><b>YIELD:</b> References the start of the Local Dial to the start of the yield of the first coordinated phase.</p> <p><b>YELLOW:</b> References the start of the Local Dial to the start of the first coordinated phase yellow.</p> <p><b>RING 1:</b> References the start of Ring 1 coordinated phase.</p> <p><b>Note • Criteria for Ring 1 are listed below.</b></p> <ul style="list-style-type: none"> <li>▪ If there is no coordinated phase on Ring 1 or the coordinated phase is in a ring that runs independently of Ring 1 (not in the same concurrent group with Ring 1 coordinated phase), the offset reference is the start of the first coordinated phase (same as LEAD).</li> <li>▪ In 3 or 4-ring configurations, TSP is not supported if the coordinated phase of Ring 1 is not the first or last coordinated phase.</li> </ul>	LEAD, LAG, YIELD, YELLOW or RING 1



MM-3-1 Parameter	Description	Range
CAL USE PED TM	<p><b>For Offset Correction, Use Pedestrian Times When Calculating Minimum Cycle</b></p> <p>Press Toggle, <b>0/YES</b>, to enable (YES) or disable (NO) using pedestrian times for minimum cycle calculations.</p> <p><b>Note</b> • <b>The minimum cycle value has effect only on subtraction during SMOOTH TRANSITION.</b></p> <p><b>YES:</b> Includes pedestrian times in minimum cycle calculation for offset correction.</p> <p><b>NO:</b> Omits pedestrian times from the minimum cycle calculation for offset correction.</p> <p><b>Note</b> • <b>NO is typically used at intersections that have little or no pedestrian movements.</b></p>	YES, NO
PED RECALL	<p><b>Coordinated Phase Pedestrian Re-service</b></p> <p>Press Toggle, <b>0/YES</b>, to enable (YES) or disable (NO) pedestrian recall (MM-2-8 and MM-3-2) during coordination.</p> <p><b>YES:</b> Allows the programmed pedestrian recall to recycle the pedestrian movement when the Coordinator Pattern has Actuated Walk programmed. The pedestrian actuations will have no effect .</p> <p><b>NO:</b> Allows only pedestrian actuations to recycle the pedestrian movement during coordination. The programmed pedestrian recall will not recycle the pedestrian movement when the Coordinator Pattern has actuated Walk programmed.</p>	YES, NO
PED RESERVE	<p><b>Pedestrian Re-service</b></p> <p>Press Toggle, <b>0/YES</b>, to enable (YES) or disable (NO) re-serviced the Walk during coordination.</p> <p><b>YES:</b> Allows the pedestrian movements to be re-serviced during coordination.</p> <p><b>NO:</b> Prevents the pedestrian movements from being re-serviced during coordination.</p> <p><b>Note</b> • <b>When pedestrian phases are re-serviced, they will return to the start of the Walk interval. Any pedestrian phase can be re-serviced when there is a pedestrian call and Walk plus Pedestrian Clear can be timed in full before the force-off point (Split Time).</b></p>	YES, NO

▪ Programming Summary

MM-3-1 Parameter	Description	Range
LOCAL ZERO OVRD	<p><b>Local Zero Override</b></p> <p><b>YES:</b> Allows the coordinator local dial to continue running and remain in synchronization with the Local Master Dial until the coordinated phase would violate the Yield point. At that time, the Local Dial stops until the coordinated phase is green and reports a local zero error.</p> <p><b>NO:</b> Normal coordinator operation. The Local Dial stops at Local Zero until the coordinated phase is green and reports a local zero error.</p> <p><b>Note</b> • Typically used on short cycles that have seldom used non-coordinated movements. Allows the non-coordinated phase(s) to use a portion of the coordinated phase split before the coordinated phase becomes green. The seldom used movement has a phase split that violated the coordinated cycle or phase split because of a pedestrian movement, density, full phase demand, or guaranteed minimum times. There will be “not reported” or “logged errors” if the coordinated phase is “can yield” by the yield point.</p>	YES, NO
FO ADD INI GRN	<p><b>Force Off Added Initial Green</b></p> <p>Press Toggle, <b>0/YES</b>, to enable (YES) or disable (NO) the Force Off of Added Initial Green by the Coordinator.</p> <p><b>Note</b> • This option allows the use of the Added Initial calculations while maintaining coordination.</p> <p><b>YES:</b> Allows the coordinator to force off the Added portion of Initial Green that was generated by volume density.</p> <p><b>NO:</b> Prevents the coordinator from Forcing off the Added portion of Initial Green that was generated by volume density.</p>	YES, NO

MM-3-1 Parameter	Description	Range
RE-SYNC COUNT	<p>Allows the coordinator to self sync when a sync pulse does not occur at Local Master Zero.</p> <p><b>0:</b> Defaults to “1” self-sync cycle.</p> <p><b>1-254:</b> Self-sync cycles that will be completed if a sync pulse does not occur. After which, Coordination reverts to Time Base operation.</p> <p><b>255:</b> Allows the coordinator to continue to re-sync until a sync pulse is detected.</p> <p><b>Note</b> • This option is used when the interconnect sync pulses are an even multiple of the local cycle.</p> <p><b>Example:</b> Set the re-sync count to 3 when:</p> <ul style="list-style-type: none"> <li>■ The interconnect sync pulse every 180 seconds.</li> <li>■ The local cycle is 60 seconds.</li> </ul>	0-255
MULTISYNC	<p>Press Toggle, <b>0/YES</b>, to enable (YES) or disable (NO) the MULTISYNC Operation.</p> <p><b>YES:</b> Allows the coordinator to receive sync pulses that represent multiple cycle lengths and synchronize to the sync pulse that represents cycle in effect.</p> <p><b>NO:</b> Resets the local master dial on every sync pulse.</p>	YES, NO

## Coordinator Pattern Data, MM-3-2

Coordinator/Split Pattern numbers default to a 1-to-1 relationship — that is, both numbers are the same.

```

COORDINATOR PATTERN [ 1]
USE SPLIT PATTERN. 1 SPLIT SUM .....0s
TS2 (PAT-OFF).. 0-1
CYCLE..... 100s STD (COS).....111
OFFSET VAL..... 0s DWELL/ADD TIME. 0
ACTUATED COORD... NO TIMING PLAN.... 0
ACT WALK REST.... NO SEQUENCE..... 0
PHASE RESRVCE.... NO ACTION PLAN.... 0
MAX SELECT..... NONE FORCE OFF.... NONE
SPLIT PREFERENCE PHASES
  PHASE[s] 1 2 3 4 5 6 7 8
SPT[ 1] 0 0 0 0 0 0 0 0
PREF 1... 0 0 0 0 0 0 0 0
PREF 2... 0 0 0 0 0 0 0 0
SPLT EXT. 0 0 0 0
VEH PERM. 0 0 0 DISP
RING DISP - 0 0 0 (RING 2-4)
  PHASE[s] 9 10 11 12 13 14 15 16
SPT[ 1] 0 0 0 0 0 0 0 0
PREF 1... 0 0 0 0 0 0 0 0
PREF 2... 0 0 0 0 0 0 0 0
          1 2
SPLIT DEMAND PTRN. xxx xxx XART PTRN. xxx
PHASE.. 1 2 3 4 5 6 7 8 9 0 1 2 3 4 5 6
COORD... . . . . .
VE RCALL . . . . .
PD RCALL . . . . .
MX RCALL . . . . .
OMIT.... . . . . .
SF OUT.. . . . . (1-8)
    
```

**When in a **hyperlink** field:**

**To follow the hyperlink:**

For ASC/3, press **SPEC FUNC**, then **NEXT DATA**.

For 2070, press **B**.

**To go back:**

For ASC/3, press **SUB MENU**.

For 2070, press **ESC**.

Hyperlink fields are shaded black and link to related displays as follows:

- USE SPLIT PATTERN is hyperlinked to MM-3-3.
- TIMING PLAN is hyperlinked to MM-2-1.
- SEQUENCE is hyperlinked to MM-1-1-1.
- ACTION PLAN is hyperlinked to MM-5-2.
- SPLIT DEMAND PATTERN is hyperlinked to MM-3-3.
- XART PATTERN is hyperlinked to MM-3-2.

This screen repeats for Coordinator Patterns 2 thru 120.

## Programming Summary

**Note** • If the Sequence is programmed in a coordinator plan, then it overrides any sequence programmed in an action plan that refers to this specific coordinator plan.

Go to MM-3-1, SPLITS IN and OFFSET IN (*Split Units* on page 8-9 and *Offset Units* on page 8-9), to select seconds or percent for SPLIT PREFERENCE PHASES and OFFSET VAL. Scroll through MM-3-2 to specify all coordinator pattern data values.

Coordination is controlled with patterns. Each pattern is defined by the associated coordination parameters programmed by the user. The pattern consists of independent cycle time, offset value, split pattern and units for offset and split values. With each pattern, you can independently select controller sequence, vehicle permissive operations, phase re-service, split extension, split demand pattern, crossing artery pattern, phase sequences, actuated coordination/walk rest, timing plan, ring displacement, split preference phases, spare outputs and time-base action plan for by-phase selection of vehicle recall, max recall, ped recall, and phase omits.

MM-3-2 Parameter	Programming Summary
COORDINATOR PATTERN	To advance to a desired pattern, enter the desired pattern number and press the <b>ENTER</b> function key.
USE SPLIT PATTERN	Selects the split pattern that this pattern will use. The split pattern has the coordinated phases selection, phase splits and modes.
TS2 (PAT-OFF)	Displays the TS2 pattern and offset that will select this pattern.
COORDINATION CYCLE LENGTH (CYCLE)	Enters the cycle length in seconds that the coordinator will use when this pattern is active. To coordinate the cycle length must be greater than 30 seconds.
STD (COS)	Enter the standard interconnect Cycle, Offset, and Split (COS) that will select this pattern.
OFFSET VALUE	Enters the value in seconds or percent that the local cycle zero will lag the system sync. This value must be consistent with the offset in selection.
DWELL/ADD TIME	A non-zero value will override the DWELL/ADD TIME setting in MM-3-1 when this pattern is in effect.
ACTUATED COORDINATED PHASE	Makes the coordinated phases non-actuated until the yield point then actuated thereafter. Required when ring split extensions, actuated walk rest or phase re-service is programmed.

▪ Programming Summary

MM-3-2 Parameter	Programming Summary
TIMING PLAN	Selects the TIMING PLAN that is in effect when this coordination pattern is selected. Changes to a timing plan are also set in all Action Plans (MM-5-2) that select that coordination pattern.
ACTUATED WALK REST	Makes the coordinated phase(s) rest in walk when actuated coordination is programmed.
SEQUENCE	Selects the controller sequence that this pattern will command.
PHASE RESERVICE	Allows the coordinator to respond to demands on any phase that has an open permissive. For phase Reservice to function, the controller must be fully actuated, including coordinated phases, actuated coordination programmed and automatic permissives enabled.
ACTION PLAN	Selects the time base action plan that will be active during this coordination pattern. The properties of the selected action plan will be “OR’ed” with those in effect. The pattern, flash, red rest and timing plan in this action plan will not be in effect.
MAX SELECT	Use this field to override the MAX SELECT setting in MM-3-1 when this pattern is in effect.
FORCE OFF	When this pattern is in effect, it overrides the FORCE OFF setting in MM-3-1.
PHASE SPLIT (SPT)	Enter the split value for each active phase.
PREFERENCE 1/2 PHASES (PREF 1, PREF 2)	Select the phases to receive any non-coordinated phase unused split time. Preference 1 phases have precedence over Preference 2 phases when unused split time is being allocated.
COORDINATED PHASE SPLIT EXTENSION (SPLT EXT)	Allows the coordinated phase in each ring to extend by actuations from the split extension time before coordinated phase split termination. Once gapped, the ring can service any open permissive phase.

MM-3-2 Parameter	Programming Summary
VEHICLE PERMISSIVE PERIODS (VEH PERM.)	<p><b>Automatic:</b> Enter zero for Vehicle Permissive Period 1 (VPP1), Vehicle Permissive Period 2 (VPP2) and Vehicle Permissive Period 2 Displacement (VPP2D).</p> <p><b>Single:</b> Enter desired single permissive period for VPP1 and zero for VPP2 and VPP2D.</p> <p><b>Dual:</b> Enter desired values for VPP1, VPP2 and VPP2D.</p>
RING DISPLACEMENT	Select the displacement or offset from ring one that an independent ring coordinated phase will start. When two or more rings have a barrier in common, the higher numbered ring is forced to use the value of the lower numbered ring.
SPLIT DEMAND PATTERN 1/2	Enter the pattern to be in effect that is used in the split demand screen. (MM-3-5) enables split demand 1 or 2.
CROSSING ARTERY (XART) PATTERN	Select the coordination pattern to be used when dual coordination is selected.
COORDINATED PHASE(S)	Select the phase(s) that will be coordinated when the Split Pattern is operational.
VEHICLE RECALLS	Select the phases that vehicle recall will be placed when the pattern is selected.
PED RECALLS	Select the phases that ped recall will be placed when the pattern is selected.
MAX RECALLS	Select the phases that max recall will be placed when the pattern is selected.
PHASE OMITTS	Select the phases that will be omitted when the pattern is selected.
SPECIAL FUNCTION OUTPUTS (SF OUT)	Select the special function outputs to be active when this coordination pattern is in effect.

▪ Programming Summary

MM-3-2 Parameter	Description	Range
COORDINATOR PATTERN	<p>Use the numeric keys (0-9) to select the number of the desired Coordination Pattern.</p> <p><b>0 (zero):</b> Selects the first Coordination Pattern that is not programmed.</p> <p><b>1-120:</b> Selects the pattern having the number entered.</p>	0-120
USE SPLIT PATTERN	<p><b>Coordination Split Pattern</b></p> <p>Use the numeric keys (0-9) to select the number of the desired Split Pattern.</p> <p>1-120 is the SPLIT PATTERN that represents the phase split values, coordinated phases, vehicle and pedestrian recalls, and phase omits that are to be used when this coordination pattern is in effect.</p>	1-120 - selects pattern
SPLIT SUM	<p>Automatic calculation of the split sum based on data entry.</p> <p><b>Note • The split sum in Free mode is composed of Minimum Green, Yellow, and Red clearance.</b></p>	N/A
TS2 (PAT-OFF)	<p>The TS2 patterns (Timing Plan – Offset) that represent this pattern are displayed for information only.</p>	N/A
CYCLE	<p><b>Coordination Cycle Length</b></p> <p>Use the numeric keys (0-9) to enter the length of the coordination cycle in seconds.</p> <p><b>0 (zero):</b> Forces Free and replaces the phase Max in effect with the split time as the Max for the phase.</p> <p><b>1-29:</b> Forces Free. This is a result of the coordinator not being able to function below 30 seconds.</p> <p><b>30-255:</b> Programs the cycle length.</p> <p><b>Note • The Offset and Split values (MM-3-1) can be in seconds or percent with cycle length between 30 and 255.</b></p> <p><b>256-999:</b> Programs the cycle length.</p> <p><b>Note • The Offset and Split values will be in percents only with cycle length greater than 255, regardless of what is programmed (MM-3-1).</b></p>	0-999



MM-3-2 Parameter	Description	Range
STD (COS)	<p><b>Cycle Offset Split (COS)</b></p> <p>This Associates the COS command with the selected Coordinator Pattern to allow different sources to select this pattern.</p> <p>Each number in the 3-digit number has a meaning:</p> <p>1<sup>st</sup> number is the <b>C</b>ycle with range of 1 thru 6</p> <p>2<sup>nd</sup> number is the <b>O</b>ffset with range of 1 thru 5</p> <p>3<sup>rd</sup> number is the <b>S</b>plit with range of 1 thru 4</p> <ul style="list-style-type: none"> <li>▶ Enter the 3-digit number for the COS command for this Coordinator Pattern.</li> </ul> <p><b>Or</b></p> <ul style="list-style-type: none"> <li>▶ To not have a COS command associated with this Coordinator Pattern, enter <b>0</b> (zero).</li> </ul> <p><b>Example:</b> Coordination Pattern 20 has a COS value of 152. If the Master sends COS command 152, it selects Coordination Pattern 20.</p>	<p>0</p> <p>or</p> <p>COS with range of 111-654</p> <p>where C=1 to 6 O=1 to 5 S=1 to 4</p>
OFFSET VAL	<p><b>Offset from the System Sync</b></p> <p>Use the numeric keys (0-9) to enter the Offset value seconds or percent depending on the programming of OFFSETS IN parameter.</p> <p>0 to (CYCLE minus 1): Time or percent that the Local Dial lags the Local Master Dial (synchronization pulse).</p> <p>CYCLE to 255: Results on the coordinator going free.</p> <p><b>Note • When the cycle length is greater than 255, the acceptable offset value is 0-255 seconds or 0-99%.</b></p> <p>Depending on the programmed offset reference (MM-3-1) this offset may be referenced to the start of the first coordinated phase green, the start of the last coordinated phase green, start of the first coordinated phase yield or the start of the first coordinated phase yellow.</p>	0-255

▪ Programming Summary

MM-3-2 Parameter	Description	Range
DWELL/ADD TIME	<p>A non-zero value will override the DWELL/ADD TIME setting in MM-3-1 when this pattern is in effect.</p> <p>When the Offset Correction is DWELL:</p> <p><b>0 (zero):</b> no override (the default). Use the maximum dwell period set in the DWELL/ADD TIME in MM-3-1.</p> <p><b>1-99:</b> If the offset is in percent, Dwell/Add Percentage that is used in place of the value entered in the DWELL/ADD TIME in MM-3-1.</p> <p><b>1-255:</b> If the offset is in seconds, Dwell/Add Time in Seconds that is used in place of the value entered in the DWELL/ADD TIME in MM-3-1</p> <p>When the Offset Correction is ADD ONLY or SMOOTH TRANSITION:</p> <p><b>0 (zero):</b> Maximum percentage of the cycle to be adjusted is determined by the DWELL/ADD TIME setting in MM-3-1.</p> <p><b>1-99:</b> Maximum percentage of the cycle to be adjusted during Add Only or Smooth Transition.</p> <p><b>Note • During Smooth Transition, the coordinator subtracts a maximum of 17% of the cycle.</b></p>	0-255
ACTUATED COORD	<p><b>Actuated Coordinated Phase</b></p> <p>Enables the coordinated phase(s) to respond to vehicle demand(s) and extend the coordinated phase between the ring split extension time before the yield point. When enabled, allows actuated walk rest to be enabled.</p> <p>Use Toggle, <b>0/YES</b>, to select YES (enable) or NO (disable) for the coordinated phases to be actuated.</p> <p><b>YES:</b> Enables the coordinated phases to respond to vehicle detector inputs and to extend the coordinated phase split after the yield point to a maximum of the SPLT EXT entry.</p> <p><b>Note • When Actuated Coordinated phase is enabled, it also allows for Actuated Walk / Rest and Phase Reservice if enabled.</b></p> <p><b>NO:</b> Disables the coordinated phase from responding to any vehicle or pedestrian detector inputs and forces Vehicle and Pedestrian Recall. It also disables the Phase Reservice.</p>	YES enables NO disables

MM-3-2 Parameter	Description	Range
TIMING PLAN	<p><b>Coordination Timing Plan</b></p> <p><b>1-4:</b> Selects the Phase TIMING PLAN that is in effect when this coordination pattern is in effect.</p> <p><b>0</b> (zero): Allows the phase timing plan in effect to be active.</p> <p><b>Note</b> • <b>The timing plan in effect may be selected by input or by Time Base Action Plan (MM-5-4), Coordinator Pattern (MM-3-3), Preemptor (MM-4-1), or Start/Flash (MM-2-5).</b></p>	0-4
ACT WALK REST	<p><b>Actuated Rest in Walk</b></p> <p>Use Toggle, <b>0/YES</b>, to select YES (enable) or NO (disable) the coordinated phase Actuated Walk to rest in walk.</p> <p><b>YES:</b> Allows actuated coordinated phase walk to rest in WALK and begin pedestrian clearance at the Yield Point.</p> <p><b>NO:</b> Allows the actuated coordinated phase to time walk and pedestrian clearance in response to a demand.</p>	YES enables NO disables
SEQUENCE	<p><b>Pattern Sequence</b></p> <p>Selects the controller sequence when a higher priority routine has not made a selection. Selection priorities, from highest to lowest are: Manual, System, Coordinator, Hardware and Time Base.</p> <p><b>0</b> (zero): Sequence selection is by other means (hardware inputs or Time Base).</p> <p><b>1-16:</b> Selects one of 16 possible configurations of sequence data (refer to NTCIP 1202, 2.5.7.5 and 2.8.3.3).</p> <p>For sequences 17 thru 20, refer to Appendix Q, <i>Diamond Intersection Application Notes</i>.</p> <p><b>17-20:</b> Selects one of 4 pre-programmed controllers (Econolite feature), each with one pre-programmed sequence:</p> <ul style="list-style-type: none"> <li>■ 17 = Diamond 4-Phase controller</li> <li>■ 18 = Diamond 3-Phase controller</li> <li>■ 19 = Diamond Separate Intersection controller</li> <li>■ 20 = Diamond NEMA controller (8 phase Standard Quad)</li> </ul>	1-16 – selects Controller 1 sequence 17-20 – selects a Diamond pre-programmed sequence 0 – allows sequence selection by others

▪ Programming Summary

MM-3-2 Parameter	Description	Range
PHASE RESRVCE	<p>Allows all phases (including the coordinated phases) to cycle between those that have open permissives and to rest in any phase. Automatic calls are only placed on the coordinated phases when it is time to return.</p> <p>Use Toggle, <b>0/YES</b>, to select YES (enable) or NO (disable) the re-servicing of phases during a single coordination cycle.</p> <p><b>YES:</b> Enables the coordinator to allow the controller to respond to demands on any phase that has an open permissive.</p> <p><b>Note</b> • <b>When you run a sequence with a leading left turn phase, you can program the coordinator to allow the leading left turn phase to be reserviced while the other ring is still servicing the coordinated phase. To enable this operation, you must program SPLIT EXT (MM-3-2) of the ring that has the leading left turn phase to allow an earlier coordinated phase yield. The leading left turn phase would then be reserviced if the phase minimum time of the leading left turn phase can be serviced in the remaining coordinated phase split.</b></p> <p><b>NO:</b> Disallows re-servicing of phases during a single coordination cycle. Once the controller has exited and returned to the coordinated phases, it will not service any demand until the next cycle.</p> <p><b>Note</b> • <b>For phase re-service to function, the controller must be fully actuated, including coordinated phases, actuated coordination programmed and automatic permissive enabled.</b></p>	<p>YES enables NO disables</p>
ACTION PLAN	<p><b>Action Plan During Coordination Pattern</b></p> <p>Selects the time base action plan that will be active during this coordination pattern. The properties of the selected action plan will be “OR’ed” with those in effect. The pattern, flash, red rest, and timing plan in this action plan will not be in effect.</p> <p>Use the numeric keys (0-9) to select the Time Base Action Plan (1-100) to be in effect or enter 0 (zero) to disable selection.</p> <p><b>0 (zero):</b> Disables any selection of a Time Base Action Plan by this Coordination Pattern.</p> <p><b>1-100:</b> Selects the Time Base Action Plan that will be in effect when this Coordinator Pattern is in effect.</p> <p><b>Note</b> • <b>The properties of this Time Base Action Plan and any other that may be in effect will be “OR’ed” with the exception of Pattern, Flash, Red Rest and Timing Plan.</b></p>	<p>0 disables 1-100 selects plan</p>

MM-3-2 Parameter	Description	Range
MAX SELECT	<p>Use this field to override the MAX SELECT setting in MM-3-1 when this pattern is in effect.</p> <p>Press Toggle, <b>0/YES</b>, to select NONE, MAXINH, MAX1, MAX2 or MAX3.</p> <p><b>NONE:</b> MAX SELECT is determined by the MAX SELECT setting in MM-3-1.</p> <p><b>MAXINH:</b> when this pattern is in effect, it overrides MAX SELECT setting in MM-3-1. This option allows the coordinator phase split to control the time a phase is allowed to be green in the selected coordination pattern only.</p> <p><b>MAX1, MAX2 or MAX3:</b> when this pattern is in effect, it overrides MAX SELECT setting in MM-3-1. This option allows the shorter of the MAX timing (MM-2-1) or the coordinator phase split to control the time a phase is allowed to be green in the selected coordination pattern only.</p>	NONE, MAXINH, MAX 1, MAX 2, MAX 3
FORCE OFF	<p><b>Determines position of the phase force off</b></p> <p>When this pattern is in effect, it overrides the FORCE OFF setting in MM-3-1.</p> <p>Press Toggle, <b>0/YES</b>, to select:</p> <p><b>NONE:</b> (default) The FORCE OFF mode is determined by the FORCE OFF setting in MM-3-1.</p> <p><b>FIXED:</b> When this pattern is in effect, it overrides the FORCE OFF setting in MM-3-1. This option will force off the phase at the fixed position in the cycle regardless of when it started.</p> <p><b>FLOAT:</b> When this pattern is in effect, it overrides the FORCE OFF setting in MM-3-1. This option will force off after it has serviced its split regardless of when it started.</p>	NONE, FIXED, FLOAT

▪ Programming Summary

MM-3-2 Parameter	Description	Range
SPT	<p>Division of cycle time into sections (split intervals) establishes the maximum amount of time that is allocated to each timing phase during coordination.</p> <p><b>IMPORTANT • Observe the CAUTIONs listed below.</b></p> <p><b>ECPI COORD = NO</b>, the coordinator will go free when:</p> <ul style="list-style-type: none"> <li>■ Entering zero for any active phase-split.</li> <li>■ Entering phase-splits that are smaller than the minimum phase time</li> <li>■ Entering splits that exceed the cycle length.</li> </ul> <p><b>ECPI COORD = YES</b>, then:</p> <ul style="list-style-type: none"> <li>■ Entering zero for any active phase-split will omit that phase.</li> <li>■ Entering phase-split(s) that are smaller than the minimum phase time(s) or that exceed the cycle length may cause loss of coordination.</li> </ul> <p><b>Note • PHASE SPLIT is the maximum amount of time available to a phase during coordination if Floating Force-Offs is in effect. If using Fixed Force Offs are in effect and the split timer starts early due to time left over from preceding phases, the phase can be extended by demand up to the force-off point. The maximum time available can only be lowered by selecting MAX SELECT (MM-3-1) and if the max time in effect is shorter than the split.</b></p>	0-255 sec. or 0-99%

MM-3-2 Parameter	Description	Range
PREF 1 PREF 2	<p><b>Preference 1 and 2 Phase Unused Split Allocation</b></p> <p><b>0:</b> Deselect or</p> <p><b>1-16:</b> Select a phase for allocation of unused split time.</p> <p><b>IMPORTANT</b> • For this feature to operate, in MM-3-1 or MM-3-2, make sure that the FORCE OFF parameter is set to FLOAT.</p> <p>You can program any unused split time from an Initial phase to time in a Subsequent/Preference phase, as needed. The Subsequent/Preference phase must be in the same ring as the Initial phase.</p> <p>Procedure:</p> <ol style="list-style-type: none"> <li><b>1</b> In PREF 1, move the cursor to the Initial phase (1-16).</li> <li><b>2</b> Enter the number of the Subsequent/Preference phase (1-16) to time any unused split time from the Initial phase. To program another Subsequent/Preference phase, repeat the procedure with PREF 2. A value of 0 in PREF 1/PREF 2 means that phase is not programmed to use its unused split time.</li> </ol> <p><b>Note</b> • If you program PREF 1 and PREF 2, the unused split time will first be available to the PREF 1 Subsequent phase to use if it maxed out in last cycle. If PREF 1 Subsequent phase does not qualify, the unused split time will be available to the PREF 2 subsequence phase. If PREF 1/PREF 2 subsequent phases do not need the Initial unused split time, the unused split time is added to the coordinated phase. The allocation of the unused split time does not affect the sum of the split time used for each ring.</p> <p><b>Example:</b> Phase sequence is</p> <p style="text-align: center;">2 1   3 4 6 5   7 8</p> <p>Phase 2, 6 are coordinated phases. Initial phase 1 has PREF 1 Phase 4. If there is any unused split time from Initial phase 1, and Subsequent phase 4 is available and maxed out during last cycle, then the unused time could be used by Subsequent phase 4 if it has the demand.</p>	0 deselects  1-16 selects

▪ Programming Summary

MM-3-2 Parameter	Description	Range
SPLT EXT	<p><b>Coordinated Phase Split Extension</b></p> <p>Vehicle extension time for an actuated coordinated phase.</p> <p>0 to (CYCLE minus 1) seconds or 0-99% allows the coordinated phase in each ring to extend by actuations from the SPLIT EXTENSION time before coordinated phase split termination. Once gapped, the ring can service any open permissive phase.</p> <p><b>Note • Requires ACTUATED COORDINATION. Units of measure will be same as the SPLIT option.</b></p>	<p>0-99%</p> <p>0-255 sec.</p>
VEH PERM. (1 <sup>st</sup> column)	<p><b>Vehicle Permissive Period 1 (VPP1)</b></p> <p>Portion of the cycle length during which phases other than the coordinated phases may be serviced. This period begins timing at the coordinated phase yield point. If Vehicle Permissive Period 2 (VPP2) or Vehicle Permissive Period 2 Displacement (VPP2D) is equal to zero, all non-coordinated phases may be serviced during this period. If VPP2 or VPP2D are not equal to zero (dual permissive operation), then only the first phase(s) following the coordinated phase(s) (first permissive phases) are serviced during this period.</p> <p>Use numeric keys (0-9) to enter 0 to (CYCLE minus 1). The units of measure are the same as for the SPLIT units (seconds or percentage).</p> <p><b>1 to (CYCLE minus 1)</b> enables the Vehicle Permissive Period 1 (VPP1) that is the portion of the cycle following Yield in which phase(s) following a coordinated phase may be serviced.</p> <p><b>Note • If VPP2 or VPP2D is zero, all phases will be serviced during VPP1.</b></p> <p><b>0 (zero)</b> enables the coordinator to calculate an “AUTO PERMISSIVE” for each phase when VPP2 is also zero.</p>	<p>0-99%</p> <p>0-255 sec.</p>



MM-3-2 Parameter	Description	Range
VEH PERM. (2 <sup>nd</sup> column)	<p><b>Vehicle Permissive Period 2 (VPP2)</b></p> <p>Portion of the cycle length during which phases other than the coordinated phases and those directly following may be serviced. This period begins timing immediately after the vehicle permissive 2 displacement period. Only phases other than those serviced during the first permissive period can be serviced as phase omits are applied to the first permissive phase(s).</p> <p>Use numeric keys (0-9) to enter 0 to (CYCLE minus 1). The units of measure are the same as for the SPLIT units (seconds or percentage).</p> <p><b>1 to (CYCLE minus 1)</b> enables VPP2 that starts after VPP2D has timed out following the Coordinator Yield. It is the portion of the subsequent cycle that phase(s) other than those that directly follow coordinated phase(s) may be serviced.</p> <p><b>Note • If VPP2 or VPP2D is zero, all phases will be serviced during VPP1.</b></p> <p><b>0 (zero)</b> enables the coordinator to calculate an “AUTO PERMISSIVE” for each phase when VPP1 is also zero.</p>	0-99% 0-255 sec.
VEH PERM. (3 <sup>rd</sup> column)	<p><b>Vehicle Permissive Period 2 Displacement (VPP2D)</b></p> <p>This starts timing at the coordinated phase yield point. At the end of this displacement period, the second permissive period begins timing.</p> <p>Use numeric keys (0-9) to enter 0 to (CYCLE minus 1). The units of measure are the same as for the SPLIT units (seconds or percentage).</p> <p><b>1 to (CYCLE minus 1)</b> is the portion of cycle between the YIELD POINT and the beginning of VPP2.</p> <p><b>0 (zero)</b> enables all phases to be serviced during the first permissive period when VPP 1 is non-zero.</p>	0-99% 0-255 sec.

▪ Programming Summary

MM-3-2 Parameter	Description	Range
RING DISP	<p><b>Ring Displacement From Ring 1</b></p> <p>Use the numeric keys (0-9) to select the displacement (Offset) from Ring Offset One that independent ring coordinated phase(s) will start.</p> <p><b>0 to (CYCLE minus 1) seconds or 0-99%</b> is the displacement Ring 1 for Rings 2, 3 and 4.</p> <p>Cycle to 255 seconds or 100-255% results in no displacement.</p> <p>The Offset for the rings are as follows:</p> <p><b>Ring 1 offset</b> is the programmed offset.</p> <p><b>Ring 2 offset</b> is the programmed offset plus the Ring 1-2 Offset.</p> <p><b>Ring 3 offset</b> is the programmed offset plus the Ring 1-3 Offset.</p> <p><b>Ring 4 offset</b> is the programmed offset plus the Ring 1-4 Offset.</p> <p><b>Note</b> • When two or more rings (1-4) have a barrier in common, the higher numbered ring is forced to use the value of the lower numbered ring.</p> <p><b>Example:</b> Rings 1 and 3 have a barrier in common. The Ring Displacement 1-3 will be ignored and Ring 3 will use the offset of Ring 1.</p>	<p>0-255 seconds</p> <p>(0 to CYCLE minus 1) or (0-99%)</p>
SPLIT DEMAND PTRN	<p><b>Split Demand Patterns 1 and 2</b></p> <p>Enter the pattern to be in effect when enabled by split demand screen (MM-3-5) programming.</p> <p>The coordinator uses these phase splits in place of those in the SPLIT PATTERN when the SPLIT DEMAND PATTERN is in effect. The coordinated phase(s) and modes are still taken from the SPLIT PATTERN.</p> <p>Use the numeric keys (0-9) to enter the number of the SPLIT DEMAND pattern to be in effect when enabled.(MM-3-5).</p> <p><b>1-120</b> selects the SPLIT PATTERN that will be in effect when SPLIT DEMAND 1 or 2 is in effect. If both are in effect, SPLIT DEMAND PATTERN 2 is selected.</p> <p><b>0 (zero)</b> disables the split demand operation.</p> <p><b>Note</b> • Crossing artery coordination takes precedence over Split demand.</p>	<p>0 disables</p> <p>1-120 selects</p>

MM-3-2 Parameter	Description	Range
XART PATTERN	<p><b>Crossing Artery Pattern</b></p> <p>Use the numeric keys (0-9) to select and enable the crossing artery operation when the Dual Coordination input is TRUE.</p> <p><b>0 (zero):</b> Disables the crossing artery coordination.</p> <p><b>1-120:</b> Selects the Split Pattern to be used when crossing artery operation is requested.</p> <p><b>Note • Crossing artery coordination takes precedence over Split demand. The crossing artery coordinated phases are programmed as CNA2 phases.</b></p>	0-120
COORD	<p><b>Coordinated Phases.</b></p> <p>Use Toggle, <b>0/8</b>, to select (X) or deselect (“.”) phases for coordination.</p> <p><b>Note • Observe the information below:</b></p> <ul style="list-style-type: none"> <li>■ All coordinated phases must be compatible (in the same concurrent group).</li> <li>■ There must be a coordinated phase entered for each ring in that concurrent group.</li> <li>■ It is permissible to have only one ring in the concurrent group.</li> </ul>	X select “.” deselect
VE RCALL	Use Toggle, <b>0/8</b> , to select (X) or deselect (“.”) phases that vehicle recall will be placed in coordination.	X select “.” deselect
PD RCALL	Use Toggle, <b>0/8</b> , to select (X) or deselect (“.”) phases that ped recall will be placed in coordination.	X select “.” deselect
MX RCALL	Use Toggle, <b>0/8</b> , to select (X) or deselect (“.”) phases that max recall will be placed in coordination.	X select “.” deselect
OMIT	Use Toggle, <b>0/8</b> , to select (X) or deselect (“.”) phases that will be omitted in coordination.	X select “.” deselect
SF OUT	<p><b>Coordinator Pattern Special Function Outputs</b></p> <p>Toggle to enable (X) or disable (“.”) up to eight special function outputs when this Coordination Pattern is in effect.</p> <p>These outputs are typically Mapped to a controller output, input, or used by a Logic Processor (MM-1-8-2) Statement.</p>	X enable “.” disable

- *Added Parameters*

## Added Parameters

The parameters that follow are not shown on any of the data entry screens. They are included here because they are necessary to understand the data entry parameters for this section.

Parameter	Description
Permissive Operation	The coordinator is programmed to calculate permissive periods by one of three operations: Automatic, Dual and Single.
Auto Permissive	Automatically computed permissive period. Each sequential phase is automatically assigned a vehicle and pedestrian permissive period. The length of the vehicle permissive period is determined by the phase split interval and phase minimum time. Phase minimum time is equal to auto permissive minimum green, bike minimum green, or phase minimum green, whichever is larger, plus the yellow and red clearance time. Auto permissive green time allows you to set the phase minimum green to a low value, yet still ensures that the auto permissive period provides sufficient green time if the controller yields to the phase at the end of the permissive.
Dual Permissive	A permissive operation that requires operator data entry of three parameter values: VEH PERM 1, VEH PERM 2 and VEH PERM 2 DISP. During this permissive operation, the Vehicle permissive period 1 times first. This period begins at the yield point. Vehicle permissive period 2 begins timing immediately after an adjustable time period (Vehicle Permissive Period 2 Displacement). During the vehicle permissive period 1, only those phases immediately following the coordinated phases are serviced. If the controller yields during the first permissive, all remaining calls are serviced in normal sequence and the second permissive period is not used.
Single Permissive	Single permissive operation is selected by setting the Vehicle Permissive 2 displacement to zero. Only the Vehicle Permissive Period 1 and its associated pedestrian permissive period are timed and begin timing at the yield point. During the Single Permissive period, the controller yields to any phase.

Parameter	Description
Permissive Period End Point	<p>End Point = (Split Sum) - (K Phase Clear) - (Perm Phase Min Green and Clear)</p> <p>Where:</p> <ul style="list-style-type: none"> <li>■ Split Sum = Sum of splits from coordinated through permissive phases, inclusive.</li> <li>■ K Phase Clear = Coordinated phase Yellow + All Red (If Walk Rest Modifier input = TRUE).</li> <li>■ K Phase Clear = Coordinated phase Ped Clear + Yellow + All Red (If Walk Rest Modifier input = FALSE).</li> <li>■ Perm Phase Min Green and Clear = Permissive phases minimum green + Yellow + All Red.</li> <li>■ Perm Phase Min Green = Permissive Phase minimum green or (Walk + Ped Clear), whichever is greater.</li> </ul>
Yield Point	Yield Point = Coordinated phase split interval - Coordinated phase clearance time (Pedestrian and vehicle clearance times).
Actuated Yield Point	Actuated Yield Point = Coordinated phase split interval - Coordinated phase clearance time(s) – Ring split extension time.
Offset Point	<p>The offset entry establishes the offset point to the:</p> <ul style="list-style-type: none"> <li>■ LEAD: Referenced the start of the Local Dial to the start of the first coordinated phase green.</li> <li>■ LAG: Referenced the start of the Local Dial to the start of the last coordinated phase green.</li> <li>■ YIELD: Referenced the start of the Local Dial to the start of the first coordinated phase yield.</li> <li>■ YELLOW: Referenced the start of the Local Dial to the start of the first coordinated phase yellow.</li> </ul>
Yield Points	The coordinator uses multiple yield points, one yield point is computed per ring. There may be four distinct yield points. Hold and Yield are independent calculations based on offset, coordinated phase splits and coordinated phase timing.
Minimum Controller Cycle Time	The shortest possible cycle length allowing all phases to time their minimum vehicle and pedestrian interval times.
Dual Coordination	Dual coordination is established when the dual coordination input is TRUE. This forces the crossing artery (XARTY PATTERN) phase splits to be used and places a continuous vehicle demand on the call-to-non-actuated 2 (CNA II) phases.

## Split Pattern, MM-3-3

The split patterns are selected by the coordination patterns and identify coordinated phase, split value and recall/omit selection. When you scroll this screen, you can specify all coordinator split pattern data values.

SPLIT PATTERN [ 1 ]																
PHASE[s]	1	2	3	4	5	6	7	8								
SPLIT	0	0	0	0	0	0	0	0								
PHASE[s]	9	10	11	12	13	14	15	16								
SPLIT	0	0	0	0	0	0	0	0								
PHASE...	1	2	3	4	5	6	7	8	9	0	1	2	3	4	5	6
COORD...	.	.	.	.	.	.	.	.	.	.	.	.	.	.	.	.
VE RCALL	.	.	.	.	.	.	.	.	.	.	.	.	.	.	.	.
PD RCALL	.	.	.	.	.	.	.	.	.	.	.	.	.	.	.	.
MX RCALL	.	.	.	.	.	.	.	.	.	.	.	.	.	.	.	.
OMIT....	.	.	.	.	.	.	.	.	.	.	.	.	.	.	.	.

**When in a **hyperlink** field:**

**To follow the hyperlink:**

For ASC/3, press **SPEC FUNC**, then **NEXT DATA**.

For 2070, press **B**.

**To go back:**

For ASC/3, press **SUB MENU**.

For 2070, press **ESC**.

The display above repeats for Split Patterns 2 through 120.

### Programming Summary

MM-3-3 Parameter	Programming Summary
SPLIT PATTERN	To advance to desired pattern, enter desired pattern number after SPLIT PATTERN then press <b>ENTER</b> . The hyperlink goes to MM-4-4, TSP/SCP SPLIT PATTERN.
PHASE SPLIT	Enter the split value for each active phase.
COORDINATED PHASE (S) (PHASE COORD)	Select the phase(s) that will be coordinated when the Split Pattern is operational.
VEHICLE RECALLS (VE RCALL)	Select the phase(s) where vehicle recalls are placed when the split pattern is operational.
PED RECALLS (PD RCALL)	Select the phase(s) where ped recalls are placed when the split pattern is operational.
MAX RECALLS (MX RCALL)	Select the phase(s) where max recalls are placed when the split pattern is operational.
PHASE OMITTS (OMIT)	Select the phase(s) that will be omitted when the split pattern is operational.

MM-3-3 Parameter	Description	Range
SPLIT PATTERN	Select the desired Split Pattern to edit or view as follows: <ul style="list-style-type: none"> <li>■ 1-120 will display the programming for the specified Split Pattern.</li> <li>■ The hyperlink goes to MM-4-4, TSP/SCP SPLIT PATTERN.</li> </ul>	1-120
PHASE SPLIT	Division of cycle time into sections (split intervals) establishes the maximum amount of time that is allocated to each timing phase during coordination. <p><b>IMPORTANT • Observe the cautions listed below.</b></p> <p><b>ECPI COORD = NO</b>, the coordinator will go free when:</p> <ul style="list-style-type: none"> <li>■ Entering zero for any active phase-split.</li> <li>■ Entering phase-splits that are smaller than the minimum phase time</li> <li>■ Entering splits that exceed the cycle length.</li> </ul> <p><b>ECPI COORD = YES</b>, then:</p> <ul style="list-style-type: none"> <li>■ Entering zero for any active phase-split will omit that phase.</li> <li>■ Entering phase-split(s) that are smaller than the minimum phase time(s) or that exceed the cycle length may cause loss of coordination.</li> </ul> <p><b>Note • PHASE SPLIT is the maximum amount of time available to a phase during coordination if Floating Force-Offs is in effect. If using Fixed Force Offs are in effect and the split timer starts early due to time left over from preceding phases, the phase can be extended by demand up to the force-off point. The maximum time available can only be lowered by selecting MAX SELECT (MM-3-1) and if the max time in effect is shorter than the split.</b></p>	0-255 sec. or 0-99%
COORD	<p><b>Coordinated Phases</b></p> <p>Use Toggle, <b>0/YES</b>, to select (X) or deselect (“.”) phases for coordination.</p> <p><b>Note • Observe the notes below.</b></p> <ul style="list-style-type: none"> <li>■ All coordinated phases must be compatible (in the same concurrent group).</li> <li>■ There must be a Coordinated phase entered for each ring in that concurrent group.</li> <li>■ It is permissible to have only one ring in the concurrent group.</li> </ul>	X select “.” deselect

▪ *Programming Summary*

<b>MM-3-3 Parameter</b>	<b>Description</b>	<b>Range</b>
VE RCALL	<p><b>Vehicle Recalls</b></p> <p>Use Toggle, <b>0/8</b>, to select (X) or deselect (“.”) phases where vehicle recall is placed in coordination.</p>	<p>X select “.” deselect</p>
PD RCALL	<p><b>Pedestrian Recalls</b></p> <p>Use Toggle, <b>0/8</b>, to select (X) or deselect (“.”) phases where ped recall is placed in coordination.</p>	<p>X select “.” deselect</p>
MX RCALL	<p><b>Maximum Recalls</b></p> <p>Use Toggle, <b>0/8</b>, to select (X) or deselect (“.”) phases where max recall is placed in coordination.</p>	<p>X select “.” deselect</p>
OMIT	<p><b>Phase Omits</b></p> <p>Use Toggle, <b>0/8</b>, to select (X) or deselect (“.”) phases that are omitted in coordination.</p>	<p>X select “.” deselect</p>



## Automatic Permissive Minimum Green, MM-3-4

### Use this display to specify all Auto Perm Minimum Green data values:

- ▶ Enter desired automatic permissive minimum green times for each phase 1-16. This time is only used in the auto-permissive calculations and has no effect on the actual phase minimum green.
- ▶ Zero entry disables the function for that phase.

AUTO PERM MINIMUM GREEN (SECONDS)								
PHASE	1	2	3	4	5	6	7	8
MIN GRN.	0	0	0	0	0	0	0	0
PHASE	9	10	11	12	13	14	15	16
MIN GRN.	0	0	0	0	0	0	0	0

### To enable automatic permissive operation:

- ▶ Go to MM-3-2 and set vehicle permissive periods (1) and (2) and vehicle permissive displacement to zero.

MM-3-4 Parameter	Description	Range
MIN GRN	<p>Select the phase minimum green time (in seconds) to be used by the coordinator.</p> <p>0-255 seconds or the phase INITIAL GREEN (MM-2-1) time, whichever is larger, is used by the auto permissive algorithm in determining the permissive for each phase.</p> <p><b>Note</b> • This entry is only in effect when the VEHICLE PERMISSIVE 1 and 2 are zero (set in MM-3-2).</p>	0-255 seconds

- Split Demand, MM-3-5

## Split Demand, MM-3-5

```

SPLIT DEMAND
  PHASES 1 2 3 4 5 6 7 8 9 0 1 2 3 4 5 6
DEMAND 1 . . . . .
DEMAND 2 . . . . .
          DEMAND 1    2
DETECTOR..... 0    0
CALL TIME (SEC).. 0    0
CYCLE COUNT..... 0    0
    
```

Use this display to specify all Split Demand data values.

Enter desired phase(s) timing, detectors and continuous detector activity to enable split demand 1 or 2. Select the number of coordinator cycles that split demand will be in operation.

MM-3-5 Parameter	Description	Range
DEMAND 1 & 2 PHASES	<p><b>Split Demand 1 &amp; 2 Phase(s)</b></p> <p>Use Toggle, <b>0/YES</b>, to select X (enable) or “.” (disable) phases for SPLIT DEMAND 1 and 2 operation.</p> <p>The coordinator uses the split values in SPLIT DEMAND PATTERN 1 or 2, as specified in COORDINATOR PATTERN (MM-3-2) when the:</p> <ul style="list-style-type: none"> <li>■ DEMAND phase(s) are timing and</li> <li>■ DEMAND DETECTOR is continuously actuated and</li> <li>■ DEMAND CALL TIME has been exceeded.</li> </ul> <p>When SPLIT DEMAND PATTERN has been selected, it remains in effect for the number of cycles set in CYCLE COUNT after the above conditions are no longer met.</p> <p><b>Note</b> • Split demand operation allows the intersection to call a different SPLIT PATTERN (MM-3-2) to service local traffic demand.</p>	X enable “.” disable

MM-3-5 Parameter	Description	Range
DETECTOR	<p><b>Split Demand Detector Assignment</b></p> <p>Use the numeric (0-9) keys to select the detector to enable the coordinator SPLIT DEMAND 1 or 2.</p> <p><b>1-64:</b> Selects the “RAW” detector input to be used. This detector need not be assigned or programmed (MM-6-2).</p> <p><b>0 (zero):</b> Disables SPLIT DEMAND operation.</p> <p><b>Note • A failed detector disables the SPLIT DEMAND 1 or 2 selections.</b></p>	0-64
CALL TIME (SEC)	<p><b>Split Demand Call Time</b></p> <p>Use the numeric (0-9) keys to enter a number (1-255) to specify a call time or enter 0 (zero) to disable the split demand operation.</p> <p><b>1-255:</b> Specifies the number of seconds of continuous detector activity while the demand phase(s) are timing. Enables SPLIT DEMAND operation.</p> <p><b>0 (zero)</b> disables the split demand operation.</p>	0 disables 1-255 selects time
CYCLE COUNT	<p><b>Split Demand Cycle Count</b></p> <p>Use the numeric (0-9) keys to specify 1-255 cycles that SPLIT DEMAND operation remains in effect after DEMAND CALL TIME conditions are no longer met.</p> <p>The coordinator uses the split values in SPLIT DEMAND PATTERN 1 or 2, as specified in COORDINATOR PATTERN (MM-3-2) when the:</p> <ul style="list-style-type: none"> <li>■ DEMAND phase/s are timing and</li> <li>■ DEMAND DETECTOR is continuously actuated and</li> <li>■ DEMAND CALL TIME has been exceeded.</li> </ul>	1-255

---

**For your notes:**

# Preempt/TSP/SCP

## Preempt Submenu, MM-4

### Programming Summary

Data Group 1 is preempt plans 1 thru 10. Data Group 2 is preemptors that require or use a filtered input.

If the ECPI Transit Signal Priority (TSP) special feature is enabled, configure with Data Group 3. Use Data Group 4 to program the NTCIP Maximum Extension and Maximum Reduction times in the SCP Split Pattern. You need a special feature Datakey® (dongle) to enable TSP/SCP.

```

PREEMPT/TSP/SCP SUBMENU

1. PREEMPT PLAN 1-10
2. ENABLE PREEMPT FILTERING & TSP/SCP
3. TSP/SCP PLAN 1-6
4. TSP/SCP SPLIT PATTERN
    
```

MM-4 Menu Option	Programming Summary
1. PREEMPT PLAN 1-10	<ul style="list-style-type: none"> <li>■ Designate track clearance phases and overlaps.</li> <li>■ Designate dwell and cycling phase(s), pedestrian(s) and overlap(s).</li> <li>■ Designate exit phases.</li> <li>■ Select phases to have calls placed at end of preempt.</li> <li>■ Enable Preemptor.</li> <li>■ Enable priority of preemptors.</li> <li>■ Designate preemption input as lock or non-lock.</li> <li>■ Enable dwell flash phases.</li> <li>■ Select dwell flash exit color.</li> <li>■ Terminate overlaps ASAP.</li> </ul>

▪ Programming Summary

MM-4 Menu Option	Programming Summary
<p>1. PREEMPT PLAN 1-10 (cont.)</p>	<ul style="list-style-type: none"> <li>■ Terminate all timing Phase.</li> <li>■ Gate down extended green Time.</li> <li>■ Specify vehicle, pedestrian and overlap indications to be as solid, flash and fast flash depending on the interval.</li> <li>■ Enable pedestrian indications to be dark.</li> <li>■ Select pedestrian clearance to time thru yellow.</li> <li>■ Program preemptor/remote flash priority.</li> <li>■ Enable preemptor interlock input.</li> <li>■ Enable track clearance re-service.</li> <li>■ Set max presence in dwell interval time.</li> <li>■ Set preemptor re-service time.</li> <li>■ Set input extend time.</li> <li>■ Enable track phase red clearance to go to green.</li> <li>■ Enable rings to be free during preemption.</li> <li>■ Enable preemptor active output.</li> <li>■ Enable preemptor active output only during dwell.</li> <li>■ Set preemptor active output condition of other priority preemptors that are not active.</li> <li>■ Set preemptor active output condition of other non-priority preemptors that are not active.</li> <li>■ Enter preemptor minimum dwell interval time.</li> <li>■ Enter preemptor exit timing plan.</li> <li>■ Enable preemption to coordination.</li> <li>■ Enter minimum preemption duration time.</li> <li>■ Enter delay time between preemptor call and start of preemption.</li> <li>■ Enter phase inhibit time.</li> <li>■ Enter min walk, pedestrian clearance, green, yellow, red entrance interval times.</li> <li>■ Enter track clearance interval times.</li> <li>■ Enter dwell exit, yellow and red interval times.</li> <li>■ Enable preemptor linking.</li> <li>■ Select spare outputs to be active during preemption.</li> </ul>

MM-4 Menu Option	Programming Summary
	<ul style="list-style-type: none"> <li>■ Select preemptor exit phase: <ul style="list-style-type: none"> <li>pedestrian</li> <li>vehicle</li> <li>queue delay</li> <li>exit to coordination, phase once <i>or</i> one free cycle</li> </ul> </li> <li>■ Select the controller timing plan to be in effect after preemption</li> <li>■ Select a conditional delay for the start of preemption</li> <li>■ Enter the minimum percent of Green necessary to time in an Interrupted Phase</li> </ul>
2. ENABLE PREEMPT FILTERING & TSP/SCP	<ol style="list-style-type: none"> <li>1 Select preemptor inputs that require filtering to separate a pulsing from a constant input.</li> <li>2 Assign preemptors to use those filtered inputs.</li> <li>3 Map TSP/SCP signals; refer to the separate manual, <i>TSP User Guide, ASC/3</i>, P/N 100-0903-003.</li> </ol>
3. TSP/SCP PLAN 1-6	For instructions to enter data in MM-4-3 and MM-4-4, refer to the <i>Transit Signal Priority (TSP) User Guide for Advanced System Controllers ASC/3</i> , P/N 100-0903-003.
4. TSP/SCP SPLIT PATTERN	

Preempt Plans 1-10, MM-4-1

Line	
1	PREEMPT PLAN [ 1]      ENABLE.... NO
2	VEH/PED 1 2 3 4 5 6 7 8 9 0 1 2 3 4 5 6
3	OVERLAP A B C D E F G H I J K L M N O P
4	TRKCLR V . . . . .
5	TRKCLR O . . . . .
6	ENA TRL . . . . .
7	DWEL VEH . . . . .
8	DWEL PED . . . . .
9	DWEL OLP . . . . .
10	CYC VEH . . . . .
11	CYC PED . . . . .
12	CYC OLP . . . . .
13	EXIT PH . . . . .
14	EXIT CAL . . . . .
15	SP FUNC . . . . . (1-8)
16	
17	ENABLE.... NO PMT OVRIDE.X INTERLOCK NO
18	DET LOCK.. X DELAY.. 0 INHIBIT... 0
19	OVERIDE FL. . DURATION 0 CLR>GRN... NO
20	TERM OLP.ASAP PC>YEL NO TERM PH NO
21	PED DARK.. NO TC RESRV. NO DWELL FL LDSW
22	LINK PMT...0 X FLCOLR GRN EXIT OPT. OFF
23	X TMG PLN...0 RE-SERV.. 0 FLT TYPE HARD
24	FREE DUR PMT R1 NO R2 NO R3 NO R4 NO
25	--TIMING-----WALK PED CL MN GR  YEL  RED
26	ENTRANCE TM. 0  255  5  4.0  1.0
27	-----MIN GR EXT GR MX GR  YEL  RED
28	TRACK CLEAR 0  255  5  4.0  1.0
29	-----MIN DL PMTEXT MX TM  YEL  RED
30	DWL/CYC-EXIT 0  0.0  0  4.0  1.0
31	PMT ACTIVE OUT.. ON PMT ACT DWELL... NO
32	OTHER - PRI PMT.OFF NON-PRI PMT....OFF
33	INH EXT TIME...25.5 PED PR RETURN...OFF
34	PRIORITY RETURN.OFF QUEUE DELAY.... OFF
35	COND DELAY.....OFF
36	PHASES        1    2    3    4    5    6    7    8
37	PR RTN%      0    0    0    0    0    0    0    0
38	PHASES        9  10  11  12  13  14  15  16
39	PR RTN%      0    0    0    0    0    0    0    0

**Note** • This screen repeats for preemptors 2 thru 10.

You can program up to 10 preempt plans. A programmed preempt plan is *not* used when its ENABLE is set to NO. Service is prioritized so that the lowest number preemptor with No Preemption Override enabled has the highest priority or can be programmed as first come, first served.

There are several data entry screens per preempt plan. Use the screens to select preemption phases, options and timing values. Priority preemptor # 1 screens are shown as examples.



**For Phases/Overlaps:**

- ▶ Use the toggle key **0/YES** to select track clearance, dwell, cycling overlaps, pedestrians and spare outputs.

**For Options:**

- ▶ Use the toggle key **0/YES** to select desired preemption option(s). YES and 'X' indicate the option is enabled.

**For Timing Values:**

- ▶ Use keypad number keys to enter timing values for delay, duration, input extension, inhibit, max presence, re-service, and minimum intervals times. Entering the desired value after the parameter enables various timing options.
- ▶ A zero (0) entry typically disables the function. For detailed explanations of these timers, reference their individual sections in the table that follows.

**For Linked Preemptors:**

- ▶ You can link Preemptors 2 thru 10 to a higher order priority preemptor. However, you cannot link Preemptor 1 to any other preemptor because it is the highest priority preemptor.

MM-4-1 Parameter	Description	Range
PREEMPT PLAN	Use the numeric keys (0-9) to select the desired Preempt (PMT) to edit or view as follows:  <b>1-10:</b> Will display programming for the specified PMT.	1-10 – goes to specified PMT
ENABLE	<b>NO:</b> This preempt operation is disabled.  <b>YES:</b> Preempt operates with the programmable configuration that has up to 16 sequences.	NO, YES

- Preempt Plans 1-10, MM-4-1

MM-4-1 Parameter	Description	Range
<b>Phase and Overlap Setting</b>		
TRKCLR V (phases)	<p><b>Track Clearance Phase(s)</b></p> <p>Phases serviced first following Initial Clearance. Each ring will time according to the Track Clearance Green, Yellow Change and Red Clearance intervals. Each ring then holds in Red transfer until all have finished their TRACK CLEARANCE timing. All rings then advance to the preemptor DWELL interval together. The Yellow and Red indication will be solid but the green will be as follows:</p> <p><b>X:</b> Solid Green when the phase is green.</p> <p><b>F1:</b> Flashing Green at 1 PPS when the phase is green</p> <p><b>F2:</b> Flashing Green at 2.5 PPS when the phase is green.</p> <p><b>F5:</b> Flashing Green at 5 PPS when the phase is green.</p> <p><b>Note</b> • Changes in flashing rate will take place when the phase green starts to time. All TRACK CLEARANCE vehicle movements must be permissive and compatible with each other (refer to <i>Phase Compatibility, MM-1-1-2</i> on page 6-11). TRACK CLEARANCE vehicle movements cannot be DWELL or CYCLING vehicle movements.</p>	X, F1, F2 or F5
TRKCLR O	<p><b>Track Clearance Overlap(s)</b></p> <p>Press Toggle, <b>0/YES</b>, to enable (X, F1, F2, F5) or disable (“.”) overlaps during Track Clearance. The Yellow and Red indication will be solid, but the Green will be as follows:</p> <p><b>X:</b> Display a solid Green when the overlap is green or timing between two included phases.</p> <p><b>F1:</b> Display a flashing Green at 1 PPS when the phase is green or is timing between two included phases.</p> <p><b>F2:</b> Display a flashing Green at 2.5 PPS when the phase is green or is timing between two included phases.</p> <p><b>F5:</b> Display a flashing Green at 5 PPS when the phase is green or is timing between two included phases.</p>	X, F1, F2, F5 enable “.” disables

MM-4-1 Parameter	Description	Range
TRKCLR O (cont.)	<p><b>Note • Observe the information below:</b></p> <ul style="list-style-type: none"> <li>■ Changes in flashing rate will take place when the phase green starts to time.</li> <li>■ All Track Clearance vehicle movements must be permissive and compatible with each other (Reference MM-1-1-2).</li> <li>■ Track Clearance vehicle movements cannot be dwell or cycling movements.</li> <li>■ Track Clearance overlap indications will only be active if they have an included phase (MM-2-2) programmed as a Track Clearance vehicle movement.</li> <li>■ All overlap operations (including lead/lag timing, protect, modified and not-overlap) will be active coming to, during, and exiting Track Clearance.</li> </ul>	X, F1, F2, F5 enable “.” disables
ENA TRL	<p><b>Trailing Overlap Timing Disabled During Preemption</b></p> <p>Toggle to disable (.) the trailing overlap Green, Yellow and Red timing during preemption.</p> <p>When enabled (X), the overlap will use its Green, Yellow and Red timing during preemption.</p>	X enables “.” disables
DWEL VEH	<p><b>Dwell Phase(s)</b></p> <p>Phases that will be first served following the TRACK CLEARANCE interval. The Yellow and Red indication will be solid but the green will be as follows:</p> <ul style="list-style-type: none"> <li><b>X:</b> Solid Green when the phase is green.</li> <li><b>F1:</b> Flashing Green at 1 PPS when the phase is green</li> <li><b>F2:</b> Flashing Green at 2.5 PPS when the phase is green.</li> <li><b>F5:</b> Flashing Green at 5 PPS when the phase is green.</li> </ul>	X, F1, F2 or F5

- Preempt Plans 1-10, MM-4-1

MM-4-1 Parameter	Description	Range
DWEL VEH (cont.)	<p><b>Note • Observe the notes below:</b></p> <ul style="list-style-type: none"> <li>■ Changes in flashing rate will take place when the phase green starts to time.</li> <li>■ All DWELL vehicle movements must be permissive and compatible with each other (refer to <i>Phase Compatibility, MM-1-1-2</i> on page 6-11).</li> <li>■ DWELL vehicle movements cannot be TRACK CLEARANCE vehicle movements.</li> <li>■ DWELL phases may not be IDENTICAL to the CYCLE phases. For example, Dwell 2/5, Cycle 2/5 is not allowed.</li> <li>■ An EXCLUSIVE PED phase may be used as a DWELL phase but its corresponding DWELL PED phase must also be selected.</li> </ul>	X, F1, F2 or F5
DWEL PED	<p><b>Dwell Pedestrian(s)</b></p> <p>Toggle to enable (X) or disable (“.”) dwell phase pedestrian movements to be served.</p> <p><b>Note • If DWELL FLASH option is enabled, no pedestrian indications can be serviced.</b></p>	X enables “.” disables
DWEL OLP	<p><b>Dwell Overlap(s)</b></p> <p>Press Toggle, <b>0/YES</b>, to enable (X, F1, F2, F5) or disable (“.”) overlaps to be first served following Track Clearance. Dwell overlap yellow and red indication will be solid, but the green will be as follows:</p> <p><b>X:</b> Solid Green when the Overlap phase is green.</p> <p><b>F1:</b> Flashing Green at 1 PPS when the phase is green.</p> <p><b>F2:</b> Flashing Green at 2.5 PPS when the phase is green.</p> <p><b>F5:</b> Flashing Green at 5 PPS when the phase is green.</p> <p><b>Note • Observe the notes below:</b></p> <ul style="list-style-type: none"> <li>■ All Dwell vehicle movements must be permissive and compatible with each other (refer to <i>Phase Compatibility, MM-1-1-2</i> on page 6-11).</li> <li>■ Dwell vehicle movements cannot be Track Clearance vehicle movements.</li> <li>■ Dwell overlap indications will only be active if they have an included phase (MM-2-2) programmed as a Dwell vehicle movement.</li> <li>■ All overlap operations (including lead/lag timing, protect, modified, and not-overlap) will be active coming to, during, and exiting Dwell interval.</li> </ul>	X, F1, F2, F5 “.” disables

MM-4-1 Parameter	Description	Range
CYC VEH	<p><b>Cycling Phase(s)</b></p> <p>Phase(s) that will be served after the DWELL phase(s). The Yellow and Red indication will be solid but the green will be as follows:</p> <p><b>X:</b> Solid Green when the phase is green.</p> <p><b>F1:</b> Flashing Green at 1 PPS when the phase is green</p> <p><b>F2:</b> Flashing Green at 2.5 PPS when the phase is green.</p> <p><b>F5:</b> Flashing Green at 5 PPS when the phase is green.</p> <p><b>Note • Observe the notes below:</b></p> <ul style="list-style-type: none"> <li>■ Changes in flashing rate will take place when the phase green starts to time.</li> <li>■ CYCLING vehicle movements cannot be TRACK CLEARANCE vehicle movements.</li> <li>■ It is NOT VALID to use EXACTLY the same phase for both a CYCLE movement and DWELL movement, for example Dwell 2,5 and Cycle 2,5. However, for example, DWELL 2,5 and CYCLE 2,6,7,8 would be acceptable; in this example, the Dwell programming tells the preemptor to service 2,5 first and then continue to the cycle phases as they have demand.</li> <li>■ If no calls exist on any of the CYCLE phases, then the preemptor will automatically apply VEHICLE calls to all CYCLE phases so the CYCLE Phases will be serviced at least once.</li> <li>■ An EXCLUSIVE PED phase may be used as a CYCLE phase but its corresponding CYCLE PED phase must also be selected.</li> </ul>	X, F1, F2 or F5 enables
CYC PED	<p><b>Cycling Pedestrian(s)</b></p> <p>Enables cycling phase pedestrian movements to be served.</p> <p>Toggle to enable (X) or disable (“.”) pedestrian movements that will be served with the CYCLING phase.</p> <p><b>X:</b> Enables pedestrian movements that can time during the CYCLING interval following the DWELL movements.</p> <p><b>Note • Although the preemptor applies CYCLE VEH calls for Cycle phases, it does not apply CYCLE PED calls.</b></p> <p>“.”: Disables pedestrian movements with the CYCLE phases.</p> <p><b>Note • If DWELL FLASH option is enabled, no pedestrian indications can be serviced.</b></p>	X enables “.” disables

- Preempt Plans 1-10, MM-4-1

MM-4-1 Parameter	Description	Range
CYC OLP	<p><b>Cycling Overlaps</b></p> <p>Press Toggle, <b>0/YES</b>, to enable (X, F1, F2, F5) or disable (“.”) overlaps to be first served following DWELL vehicle movements. Dwell overlap yellow and red indication will be solid, but the green will be as follows:</p> <p><b>X:</b> Solid Green when the Overlap phase is green.</p> <p><b>F1:</b> Flashing Green at 1 PPS when the phase is green.</p> <p><b>F2:</b> Flashing Green at 2.5 PPS when the phase is green.</p> <p><b>F5:</b> Flashing Green at 5 PPS when the phase is green.</p> <p><b>Note • Observe the notes below:</b></p> <ul style="list-style-type: none"> <li>■ Cycling vehicle movements cannot be Track Clearance vehicle movements.</li> <li>■ Cycling overlap indications will only be active if they have an included phase (MM-2-2) programmed as a Cycling movement.</li> <li>■ All overlap operations (including lead/lag timing, protect, modified, and not-overlap) will be active coming to, during, and exiting DWELL and Cycling phases.</li> </ul>	X, F1, F2, F5 “.” disables
EXIT PH	<p><b>Preemption Exit Phase(s)</b></p> <p>With exit phase(s) enabled, the preemption sequence terminates when all exit phases are timing.</p> <p>When no exit phase is enabled and the PMT TO COORD option is not active, the preemptor terminates immediately and exits from the CYCLING interval directly to normal controller operation.</p> <p>When no exit phase is enabled and the PMT TO COORD option is active, the preemptor will terminate and exit from the CYCLING interval directly to the lowest priority phase(s) that have an open coordination permissive window. This allows the preemptor to exit directly into coordination without requiring a pickup cycle or transition.</p> <p><b>Note • EXIT phases must be permissive and compatible with each other (Reference MM-1-1-2).</b></p>	X enables
EXT CAL	<p><b>Preemption Exit Phase Vehicle Calls</b></p> <p>The phase(s) that the preemptor enters a vehicle call when exiting preemption.</p>	X enables

MM-4-1 Parameter	Description	Range
SP_FUNC	<p><b>Preemptor Special Function Outputs</b></p> <p>Toggle to enable (X) or disable (“.”) up to eight Special Function outputs when this preemptor is in effect.</p> <p>These outputs are typically Mapped (MM-1-8) to a controller output, input, or used by a Logic Processor (MM-1-8) Statement.</p>	<p>X enables “.” disables</p>
<b>Feature Enable/Disable</b>		
ENABLE	<p><b>Preemptor Enable (ECPI feature)</b></p> <p><b>NO:</b> Disable TSP/SCP operation called from this input.</p> <p><b>YES:</b> Standard phasing as programmed in (MM-1-1-1) and (MM-1-1-2).</p>	<p>NO, YES</p>
PMT_OVERRIDE	<p><b>Preemptor Overrides Higher Numbered Preemptor Disable</b></p> <p><b>Note</b> • A Higher Priority preempt <i>can not</i> interrupt a preempt currently entering or timing TRACK CLEAR. The interrupted preempt will finish timing its TRACK CLEAR and only then will it terminate so that the Higher Level Preempt can run.</p> <p><b>X:</b> Allows this preemptor to override all higher numbered preemptors. (Example: 2=X overrides 3 through 10)</p> <p><b>“.”:</b> Disables this preemptor from overriding the next active higher numbered preemptor.</p>	<p>X, “.”</p>

- Preempt Plans 1-10, MM-4-1

MM-4-1 Parameter	Description	Range
PMT_OVERRIDE (cont.)	<p><b>Example:</b> Preemptor 1 is the highest priority preemptor.</p> <p>Preemptor 2 has priority over all other active preemptions except preemptor 1.</p> <p>Preemptors 3-6 are equal and are serviced on a first-come, first-served basis. They all override preemptors 7-10.</p> <p>Preemptors 7- 10 are equal and are serviced on a first-come, first-served basis.</p> <p>PREEMPTOR_OVERRIDE programming example to accomplish the above:</p> <p>1 = .</p> <p>2 = X</p> <p>3 = .</p> <p>4 = .</p> <p>5 = .</p> <p>6 = X</p> <p>7 = .</p> <p>8 = .</p> <p>9 = .</p> <p>10 = (does not care)</p>	X, “.”
INTERLOCK	<p><b>Preemptor Interlock Enable</b></p> <p><b>YES:</b> Enables Preemptor Interlock. The PMT Interlock input must remain at logic ground or TRUE state until that preemptor has an active input and at logic high or FALSE state when that preemptor input is active. If this condition is not met for at least 1 second and the preemptor is programmed, the controller will revert to flash.</p> <p><b>Note</b> • Each of the 10 preempt inputs have a corresponding Interlock Input EXCEPT for Preempts 1 &amp; 2 which SHARE Interlock Input #1. As a result, Interlock Input #2 is NEVER used.</p> <p><b>NO:</b> Disables PREEMPTOR INTERLOCK. The PMT interlock input has no effect on controller operation.</p>	YES, NO



MM-4-1 Parameter	Description	Range
INTERLOCK (cont.)	<p><b>Preemptor Interlock Enable</b></p> <p><b>Example:</b> Preemptor 1-2 Interlock enabled.</p> <p>Preemptor 1 or 2 are not active or timing Initial/Track Clearance:</p> <ol style="list-style-type: none"> <li><b>1</b> Activate preemptors 1 and 2.</li> <li><b>2</b> Clear to all red after Track Clearance.</li> <li><b>3</b> Go to a latched flash condition by forcing Voltage Monitor/ Fault Monitor FALSE.</li> </ol> <p>Preemptor 1 is active after termination of Track Clearance:</p> <ol style="list-style-type: none"> <li><b>1</b> Clear to all red.</li> <li><b>2</b> Go to a latched flash condition by forcing Voltage Monitor/ Fault Monitor FALSE.</li> </ol> <p>Preemptor 2 is active and after termination of Track Clearance and Preemptor 1 is not programmed:</p> <ol style="list-style-type: none"> <li><b>1</b> Clear to all red.</li> <li><b>2</b> To go to a latched flash condition, force Voltage/Fault Monitor false.</li> </ol> <p>Preemptor 2 is active and after termination of Track Clearance and Preemptor 1 is programmed:</p> <ol style="list-style-type: none"> <li><b>1</b> Activate preemptor 1 and 2 inputs.</li> <li><b>2</b> Clear to all red after Track Clearance.</li> <li><b>3</b> Go to a latched flash condition by forcing Voltage Monitor/ Fault Monitor FALSE.</li> </ol> <p>Any preemptor is terminating (Going to Exit phase(s) or exiting Preemptor Flash):</p> <ol style="list-style-type: none"> <li><b>1</b> Restart the Preemptor 1 or 2 if either is timing</li> <li><b>2</b> Activate preemptor 1 and 2 inputs</li> <li><b>3</b> Clear to all red after Track Clearance.</li> <li><b>4</b> Go to a latched flash condition by forcing Voltage Monitor/ Fault Monitor FALSE.</li> </ol> <p><b>Note</b> • The preempt logic gives the preempt and interlock inputs 3 seconds to stabilize before it checks if they are logically opposite.</p>	YES, NO

- Preempt Plans 1-10, MM-4-1

MM-4-1 Parameter	Description	Range
DET LOCK	<p><b>Latched Preemptor Call During Delay</b></p> <p>A preemptor may have either latched (X) or non-latched (.) detector inputs. The non-latched parameter is in effect only during delay time.</p> <p>“.” (Non-Latched): If preemptor call is dropped during delay time, the preemptor is not serviced.</p> <p>X (Latched Detector): If preemptor call is dropped during delay time, the preemptor is serviced. Latched call until preemptor is serviced.</p>	X, “.”
DELAY	<p><b>Delay Time</b></p> <p>The time between receipt of preemptor call and initialization of preemption movements. If preemption is not active when the call is not locked, then preemption is removed before the delay timing period expires. Zero entry causes no delay before the preempt input is acknowledged.</p>	0-65535 sec.
INHIBIT	<p><b>Inhibit Time</b></p> <p>The last portion of delay time, during which phases that are not scheduled for service at the beginning of the preemption sequence, and all pedestrian movements are inhibited. Inhibit time must be less than or equal to delay time. Zero entry causes no inhibit time at the beginning of the preemption sequence.</p>	0-255 sec.
OVERRIDE FL	<p><b>Preemption Has Priority Over Automatic Flash</b></p> <p>“.”: Allows automatic flash to continue. Automatic flash will terminate until after the preemption input is removed.</p> <p>X: Allows the preemptor to override automatic flash and time the preemptor sequence. The preemptor forces the exit from automatic flash, times the complete preemption sequence and then allows the controller to return to automatic flash.</p> <p>This complies with the NEMA TS2 3.4.6 priority list.</p>	X, “.”
DURATION	<p><b>Minimum Duration Time</b></p> <p>Required minimum time that the preempt run must be active. It begins timing at the end of the Delay Interval. A preempt run MAY NOT EXIT until this timer has expired.</p> <p>With no Dwell phases programmed, a Zero entry allows preempt to exit immediately after the Track Clearance interval if the preempt input is no longer present. However, if Dwell phases are programmed, then the Dwell phases will be serviced for their MIN DL time before the preemptor exits.</p>	0-65535 sec.

MM-4-1 Parameter	Description	Range
CLR>GRN	<p><b>Yellow Clearance Reverts to Green</b></p> <p><b>YES:</b> Allows a phase to go immediately to green if it has been timing a YEL Clearance interval when the preemption call is received and the interval to time next during preemption is that same phase green.</p> <p><b>NO:</b> Forces the phase and will proceed through red revert in the normal sequence.</p> <p><b>Note</b> • You can <i>not</i> enable (YES) this entry and TERM PH at the same time because they would be in direct conflict with one another. This feature is automatically disabled if a Lagging Ovp Green starts timing on the way to Preempt.</p>	YES, NO
TERM OLP	<p><b>Terminate Overlaps As Soon As Possible.</b></p> <p><b>ASAP:</b> Forces overlaps to terminate immediately with their included phase and ignore any Lagging Overlap programming.</p> <p><b>NO:</b> Allows overlaps to terminate nominally when the last overlap included phase reaches the preemptor minimum yellow interval.</p>	ASAP, NO
PC>YEL	<p><b>Pedestrian Clearance Through Yellow</b></p> <p><b>YES:</b> Allows the Yellow Change indication to time with the completion of Pedestrian Clearance interval when entering preemption.</p> <p><b>NO:</b> Provides normal pedestrian termination when entering preemption. The Yellow Change interval is after the completion of Pedestrian Clearance.</p>	YES, NO
TERM PH	<p><b>Preemptor Terminate Phases</b></p> <p>TOGGLE to enable (YES) or disable (NO) the option for the controller to always terminate all timing phases before entering a preempt run. This has the effect of forcing an ALL RED condition before the preempt starts.</p> <p><b>YES:</b> Terminate all timing phases and force an ALL RED condition before starting the activated preempt. Phases will NOT be terminated if the current GREEN phases exactly match the Preempt's entry phase(s) and the entry phase(s) will not cause a Yellow Trap for conflicting PPLT type Overlap (MM-2-2) programming.</p> <p><b>NO:</b> Controller only terminates phases not required by the activated Preempt run.</p> <p><b>Note</b> • You can <i>not</i> enable (YES) this entry and CLR&gt;GRN at the same time because they would be in direct conflict with one another.</p> <p>In order to accommodate a PPLT during preemption, program the designated phase/overlap type that is associated with the PPLT to F1 (1 PPS flash).</p>	YES, NO

- Preempt Plans 1-10, MM-4-1

MM-4-1 Parameter	Description	Range
PED DARK	<p><b>Pedestrian Indications Dark</b></p> <p><b>YES:</b> Turns OFF all pedestrian output indications while the preemptor is ACTIVE.</p> <p><b>NO:</b> Allows pedestrian indications to follow other preemptor programming.</p>	YES, NO
TC RESRV	<p><b>Track Clearance Re-Service</b></p> <p><b>YES:</b> Allows the preemptor to re-service the track clearance phases when the preemption call goes away and returns before the preemption sequences terminate. With this option enabled, the PREEMPTION EXTEND option is disabled.</p> <p><b>NO:</b> Disables re-servicing the preemption track clearance phases while in the preemption sequence.</p>	YES, NO
DWELL FL	<p><b>Dwell Phases Flash During the Dwell Interval</b></p> <p>When the preemptor advances to the dwell interval (dwell phases may or may not be programmed), the load switch outputs behave as follows:</p> <p><b>OFF:</b> Load switch outputs do not flash.</p> <p><b>LDSW:</b> Causes the preemption DWELL phases to flash yellow while all other phases flash red. DWELL FLASH operation is limited to one phase per ring that are also permissive phases.</p> <p><b>Note</b> • <b>This Flash exits to either the Exit Phases or (if no exit phases) to the Dwell Phases.</b></p> <p><b>MON:</b> On NEMA cabinet, controller forces the controller to drop CVM and puts the intersection into CABINET FLASH. On 300 Series cabinet, for this to work, Conflict Monitor needs to have watchdog latching disabled. In this mode, Watchdog can be stopped to produce cabinet flash.</p> <p>Upon exiting PMT, the controller will time the POWER-UP RED before going to the Start-up phases as programmed in MM-2-5.</p>	OFF, LDSW, MON

MM-4-1 Parameter	Description	Range
LINK PMT	<p><b>Preemptor to be Linked to this Preemptor</b></p> <p>Select a higher priority (lower numbered) preemptor to be linked to this preemptor. The linked preemptor will be called when this preemptor completes the programmed minimum dwell time. The call to the linked preemptor will be maintained as long as demand for this preemptor is present. Calls to any lower priority or not valid preemption sequence will be ignored.</p> <p>The linking preemptor feature allows multiple track clearances or complex preemption sequences with one preemptor calling another.</p> <p><b>Example:</b> Preemptor 3 is linked to 2, it will go through its TRACK CLEARANCE interval and start the DWELL interval.</p> <p>When the MIN DWELL-CYC GRN time is elapsed, a call is then placed on preemptor 2. This transfers control to preemptor 2. Preemptor 2, in turn, can then be linked to preemptor 1.</p> <p>This example creates a possibility of five phase clearance prior to getting to the preemptor 1 DWELL interval and timing its phases.</p> <p><b>IMPORTANT</b> • <b>The MAX PRESENCE time for each preemptor must be taken into account when this feature is used to insure the desired operation.</b></p>	0-9
X FLCOLR	<p><b>Dwell Flash Exit Color</b></p> <p>Press Toggle, <b>0/YES</b>, to select RED, YEL or GRN. The controller will exit from DWELL phase flash to the selected color indication.</p> <p><b>Note</b> • <b>For this option to operate, you must also select either DWELL PHASES and/or EXIT PHASES. TRACK CLEARANCE vehicle movements cannot be an EXCLUSIVE PED Phase.</b></p>	RED, GRN, YEL
EXIT OPT	Refer to <i>EXIT OPT</i> on page 9-26.	OFF, CRD, XPH, CYC
X TMG PLN	Refer to <i>X TMG PLN</i> on page 9-26.	0-4

- Preempt Plans 1-10, MM-4-1

MM-4-1 Parameter	Description	Range
RE-SERV	<p><b>Low Priority Preemption Re-service Time</b></p> <p>Selects the time that a low priority preemptor is inhibited after preemption.</p> <p><b>Note</b> • <b>Observe the notes listed below for MM-4-2.</b></p> <ul style="list-style-type: none"> <li>■ If both the SOLID and PULSING columns are BYPASSED for an input, then it is a High Priority input.</li> <li>■ If either or both columns do NOT have a BYPASSED entry, then the input is Low Priority.</li> </ul> <p><b>0 (zero):</b> Disables re-service Operation</p> <p><b>255:</b> Requires all active phases with calls, when the preemptor exits, to be serviced before preemption can be serviced.</p> <p><b>1 – 254:</b> Specifies the minimum time allowed between low priority PMT calls.</p> <p><b>Note</b> • <b>This feature is disabled if the preemptor is not called by a low priority input (determined by MM-4-2).</b></p>	0-255 sec.
FLT TYPE	<p><b>High Priority Preemptor Fault Type</b></p> <p>You can treat the Gate Down Fault and the IEEE 1570 related fault as an automatically recoverable fault or not.</p> <p><b>SOFT:</b> Fault is automatically recoverable when the fault condition ceases to exist:</p> <ul style="list-style-type: none"> <li>■ Gate Down Fault – terminates when preemptor is deactivated.</li> <li>■ When IEEE-1570 is enabled – these faults will be detected: <ul style="list-style-type: none"> <li>Not receiving HRI RCOS</li> <li>HRI RCOS SO is off</li> <li>HRI RCOS RBHA is off</li> </ul> </li> </ul> <p>When set to SOFT, the controller will stay in flash for at least 60 seconds before exit if it is recovered from an IEEE 1570 fault.</p> <p><b>HARD:</b> User intervention is required to clear the fault. Controller will stay in Flash until you press <b>CLEAR</b> or <b>MMU Reset</b>.</p> <p>This setting is per Preempt for Gate Down fault, but general for all IEEE 1570 related faults.</p> <p>This setting is only applicable for high priority preempts (for train) in which both SOLID and PULSING columns in MM-4-2 are set to BYPASSED.</p>	HARD, SOFT

MM-4-1 Parameter	Description	Range
FREE DUR PMT	<p><b>Free During Preemption</b></p> <p><b>YES:</b> Enables an independent ring to time nominally during preemption if the ring has no phases or barriers in common with any phase programmed in the preemptor.</p> <p><b>NO:</b> Forces all phases in the ring to be red unless the phases are programmed in the preemptor to be active.</p> <p><b>Note</b> • The user may only select those rings to go FREE that are NOT part of the logical controller in preempt. Example: If the unit is programmed to use 3 rings for one intersection, the user may NOT select IN PREEMPT for rings 1 and 2, but FREE for ring 3.</p>	YES, NO
<b>Timing Parameters</b>		
ENTRANCE TM  WALK  PED CL  MN GR  YEL  RED	<p><b>Preemption Entrance Minimum Times</b></p> <p>Enter the minimum times for the phases that are active when the preemptor becomes active.</p> <p><b>WALK:</b> 0-255 sec.</p> <p><b>PED CL: (PEDESTRIAN CLEARANCE):</b> 0-255 sec.</p> <p><b>MN GR (GREEN):</b> 0-255 sec.</p> <p><b>YEL (YELLOW CHANGE):</b> 0.0-25.5 sec.</p> <p><b>RED (RED CLEARANCE):</b> 0.0-25.5 sec.</p> <p><b>Note</b> • Programming these values to 255 and 25.5 respectively, allows the phase minimum times to be used. There is no way for the phase indication time to be larger than their programming when entering preemption.</p> <p><b>IMPORTANT</b> • If these values are set to zero and the <b>GUARANTEED MINIMUM TIMES</b> are also zero, the indication will terminate immediately when entering preemption regardless of the time on the phase. This can result in a clearance indication being omitted or shorter than the MMU minimum clearance time resulting in a <b>LATCHED MMU Minimum Clearance</b> failure.</p>	0, 0-25.5 sec.  or  0-255 sec

- Preempt Plans 1-10, MM-4-1

MM-4-1 Parameter	Description	Range
TRACK CLEAR MIN GR	<p><b>Track Clearance Time, Minimum Green</b></p> <p><b>MIN GR: 0-255</b> sec. TC Green, The preemptor times this setting regardless of the phase timing. In any case, the indications will not time less than the GUARANTEED MINIMUM TIMES (MM-2-4).</p> <p><b>Note</b> • <b>0 (zero):</b> Track clearance green time omits the track clearance interval regardless of programming.</p> <p><b>Note</b> • Programming this value to 255 allows the phase minimum times to be used.</p> <p><b>IMPORTANT</b> • If the setting of these clearance values is zero and the GUARANTEED MINIMUM TIMES are also zero, the indication will terminate immediately when exiting track clearance regardless of the time on the phase. This can result in a clearance indication being omitted or shorter than the MMU minimum clearance time resulting in a LATCHED MMU Minimum Clearance failure.</p>	0-255 sec
TRACK CLEAR EXT GR	<p><b>Track Clearance Time, Preemptor Gate Down Ext Green</b></p> <p><b>Note</b> • For this feature to operate, GATE DWN EXT GR and GATE DWN MAX GRN must be programmed.</p> <p><b>0.0</b> (zero) disables the Gate Down option.</p> <p><b>0.1 to 25.5 sec.:</b> This timing will extend the TRACK CLEAR green time after the GATE DOWN input is received.</p> <p>This enables any cars that have just crossed the tracks to get through the intersection on a Green light.</p> <p><b>IMPORTANT</b> • If the gate down maximum green timer times out, the preemptor will force the intersection into flash!</p> <p><b>Note</b> • This timing only takes effect after the TRACK CLEAR Minimum Green time is complete and the GATE DOWN input has been received. If the GATE DOWN signal never happens, then the Extend Green Time will never time and eventually the controller will go into GATE DOWN FAULT FLASH.</p>	0 - 25.5 sec
TRACK CLEAR MX GR	<p><b>Track Clearance Time, Maximum Track Clear Green</b></p> <p><b>Note</b> • GATE DWN EXT GR and GATE DWN MAX GRN must be programmed for this feature to operate.</p> <p><b>0</b> (zero) disables the Gate Down option.</p> <p><b>1 - 255 sec.:</b> The maximum time that Track Clear Green may be serviced when being extended by the Gate Down feature.</p> <p><b>IMPORTANT</b> • If the gate down maximum green timer times out, the preemptor will force the intersection into flash!</p>	0 - 255 sec



MM-4-1 Parameter	Description	Range
TRACK CLEAR YEL  TRACK CLEAR RED	<p><b>Track Clearance Time, Yellow or Red</b></p> <p><b>YEL/ RED: 0.0 - 25.5</b> sec TC Yellow or Red also times the programmed value unless a value of 25.5 is used. In that case, the controller uses the phase's programmed time (MM-2-1). In any case, the indications will not time less than the GUARANTEED MINIMUM TIMES (MM-2-4).</p> <p><b>Note</b> • Programming these values to 25.5 allows the phase minimum times to be used.</p> <p><b>IMPORTANT</b> • If the setting of these clearance values is zero and the GUARANTEED MINIMUM TIMES is also zero, the indication will terminate immediately when exiting track clearance regardless of the time on the phase. This can result in a clearance indication being omitted or shorter than the MMU minimum clearance time resulting in a LATCHED MMU Minimum Clearance failure.</p>	0.0 - 25.5 sec.
MIN DL (time)	<p><b>Preemptor Minimum Dwell Time</b></p> <p><b>0 – 255:</b> The minimum time (in seconds) for the DWELL and CYCLING Phases. After this time the preemptor waits for the duration time to be complete and the preemption input to go FALSE before exiting.</p>	0 - 255 sec
PMT EXT	<p><b>Preemption Input Extension time.</b></p> <p>Preemptor remains in dwell interval for EXTEND INPUT time when preempt call is removed. If preempt call is reapplied during this time, the preemptor reverts to start of dwell interval. Zero entry causes no input extension time and dwell interval ends when the preempt call is removed.</p>	0.0 - 25.5 sec.
MX TM	<p><b>Preemptor Maximum Presence Interval</b></p> <p>The maximum time that a preemption call can be active and be recognized by the controller. When it has failed, the input must return to inactive state to be recognized again. Zero entry disables the function for the associated preempt run.</p> <p><b>Note</b> • This feature is disabled if the preemptor is <i>not</i> called by a low priority input (determined by MM-4-2).</p>	0 - 65535 sec.

- Preempt Plans 1-10, MM-4-1

MM-4-1 Parameter	Description	Range
YEL/RED (times)	<p><b>Exit Yellow Change and Red Clearance times when Exiting Preemption</b></p> <p>Depends on exit phase and automatic flash priority programming.</p> <p><b>0.0 – 25.5:</b> The preemptor times (in seconds) the smaller of these settings or the phase programmed times (MM-2-1). In any case, the indications will not time less than the GUARANTEED MINIMUM TIMES (MM-2-4).</p> <p><b>IMPORTANT</b> • If the setting of these values is zero and the GUARANTEED MINIMUM TIMES is also zero, the indication will terminate immediately when exiting preemption regardless of the time on the phase. This can result in a clearance indication being omitted or shorter than the MMU minimum clearance time resulting in a LATCHED MMU Minimum Clearance failure.</p>	0.0 - 25.5 sec.
<b>Preemptor Active Output Statuses</b>		
PMT ACTIVE OUT	<p><b>Preemption Active Output</b></p> <p>Toggle to enable/disable the preemptor status output while the preempt Input is active.</p> <p><b>ON:</b> Enable solid.</p> <p><b>F1:</b> Enable flash at 1pps.</p> <p><b>F2:</b> Enable flash at 2.5pps.</p> <p><b>F5:</b> Enable flash at 5pps.</p> <p><b>OFF:</b> Disable.</p> <p>Depending on the PMT ACT DWELL programming, it may be output only during the dwell interval.</p>	ON, enable F1, F2, F5 = flash at 1, 2.5, or 5 pps  OFF, disable
PMT ACT DWELL	<p><b>Preemption Active Output Only In Dwell.</b></p> <p><b>Toggle to enable (YES) or disable (NO)</b> the Preemptor Status output only during the DWELL/CYCLIC interval.</p> <p><b>Note</b> • This is ON only during the green dwell interval; it is not ON during the dwell clearance interval.</p> <p>When disabled, the Preemptor Status is output as long as the preemptor is active.</p>	YES, enable  NO, disable

MM-4-1 Parameter	Description	Range
OTHER – PRI PMT	<p><b>Other Priority Preemptor Active Output(s)</b></p> <p>Toggle to enable/disable the preemptor status outputs of the other priority preemptors:</p> <p><b>ON:</b> Enable solid.</p> <p><b>F1:</b> Enable flash at 1pps.</p> <p><b>F2:</b> Enable flash at 2.5pps.</p> <p><b>F5:</b> Enable flash at 5pps.</p> <p><b>OFF:</b> Disable</p> <p><b>Note • The status output will be OFF if the preemptor is not enabled.</b></p>	<p>ON = enable</p> <p>F1, F2, F5 = flash at 1, 2.5, or 5pps</p> <p>OFF = disable</p>
NON-PRI PMT	<p><b>Other (non-active) Non-Priority Preemptor Active Output(s)</b></p> <p>Toggle to enable/disable the preemptor status outputs of the other non-priority preemptors:</p> <p><b>ON:</b> Enable solid.</p> <p><b>F1:</b> Enable flash at 1pps.</p> <p><b>F2:</b> Enable flash at 2.5pps.</p> <p><b>F5:</b> Enable flash at 5pps.</p> <p><b>OFF:</b> Disable.</p> <p><b>Note • The status output will be OFF if the preemptor is not enabled.</b></p>	<p>ON = enable</p> <p>F1, F2, F5 = flash at 1, 2.5, or 5pps</p> <p>OFF = disable</p>
INH EXT TIME	<p><b>Inhibit Extension Timer</b></p> <p>This parameter improves the operation of MX TM (Maximum Preemption Call Time), which is also in this MM-4-1 screen. You can program the Inhibit Extension Timer for each of the 10 Preempt Runs.</p> <p>This feature keeps the MX TM timing during brief interruptions of reception of the Preempt signal emitted by an emergency vehicle. For example, a high profile truck could drive by and briefly block (inhibit, INH) the signal and give a false indication that the emergency vehicle has stopped generating the signal. With this parameter, the MX TM will continue timing (and not reset) if the Preempt signal is again received before this INH EXT TIME times out.</p> <p><b>0-25.5:</b> Enter the time (seconds) to let the Maximum Preemption Call Time (MX TM) continue to time during the interruption of the receipt of a Preempt emergency signal.</p>	<p>0-25.5 seconds</p>

- Preempt Plans 1-10, MM-4-1

MM-4-1 Parameter	Description	Range
<b>Preemptor Exit Phases</b>		
	<p><b>Note</b> • With respect to the preemptor exit phase parameters that follow, if you enable multiple exit strategies, they are processed in the order listed below. If a higher priority strategy is not satisfied, then the next highest will be evaluated.</p> <p>For example, if both Ped Priority Return (3<sup>rd</sup> in the list) and Priority Return (4<sup>th</sup> in the list) are enabled but no Ped Priority Exit Phase is found (Preempt did not interrupt a ped movement), then the preempt exit logic will check if any phases met the criteria for a Priority Return Exit Phase.</p> <ol style="list-style-type: none"> <li>1. Exit from CVM preempt flash state (preempt exits to programmed start-up phases)</li> <li>2. Exit to pending preempt</li> <li>3. Ped priority return (PED PR RETURN)</li> <li>4. Veh priority return (PRIORITY RETURN)</li> <li>5. Queue delay recovery (QUEUE DELAY)</li> <li>6. The selection for EXIT OPT in this Preempt Plan: exit to coordination (CRD), exit to phase once (XPH) or exit one free cycle (CYC).</li> <li>7. Programmed exit phases</li> <li>8. Currently GREEN phases</li> <li>9. The next phase in the sequence rotation with a demand</li> </ol>	
PED PR RETURN	<p><b>Pedestrian Priority Return Exit Option</b></p> <p>Toggle to enable/disable the preemptor to check if the Walk or Ped Clear timing has been interrupted by a preempt:</p> <p><b>OFF:</b> Disabled</p> <p><b>ON:</b> Enabled ALWAYS</p> <p><b>TOD:</b> Enabled only by Time-of-Day (TOD)</p> <p>When this is enabled, the preemptor will determine if WALK or PED CLEAR timing has been shortened by the preemptor as it attempts to start. If so, then those interrupted PEDs will be selected as PED PRIORITY RETURN Exit phases.</p>	OFF, ON, TOD

MM-4-1 Parameter	Description	Range
<b>Preemptor Exit Phases, continued</b>		
PRIORITY RETURN	<p><b>Vehicle Priority Return Exit Option</b></p> <p><b>Note</b> • Interrupted Phases = phases timing when the preemptor tries to start.</p> <p>Toggle to enable/disable the preemptor to determine if an Interrupted Phase will be selected as an exit phase:</p> <p><b>OFF:</b> Disabled</p> <p><b>ON:</b> Enabled ALWAYS</p> <p><b>TOD:</b> Enabled only by Time-of-Day (TOD)</p> <p>When this is enabled, the preemptor:</p> <ol style="list-style-type: none"> <li><b>1</b> Calculates the % Green timed of the Interrupted Phases.</li> <li><b>2</b> Compares the % Green timed with the % value you entered in PR RTN% for the Interrupted Phases.</li> <li><b>3</b> If the % Green is <i>less than</i> the % value you entered in PR RTN% for a phase, then selects that Interrupted Phase as a Veh Priority Return Exit phase.</li> </ol> <p><b>Note</b> • For details about PR RTN%, refer to <b>PR RTN%</b> on page 9-27.</p>	OFF, ON, TOD
QUEUE DELAY	<p><b>Queue Delay Recovery Option</b></p> <p>Toggle to:</p> <p><b>OFF:</b> Disabled</p> <p><b>ON:</b> Enabled ALWAYS</p> <p><b>TOD:</b> Enabled only by Time-of-Day (TOD)</p> <p>When this is enabled, the preemptor:</p> <ol style="list-style-type: none"> <li><b>1</b> Checks phase wait time since last demand (WT).</li> <li><b>2</b> Checks the number of cars waiting for service (CW).</li> <li><b>3</b> Selects the phases with the greatest WT x CW values as possible Exit Phases, one phase per ring. If the weighted delays for two phases are equal, the next in the sequence is served first.</li> </ol> <p><b>Example:</b> Phase A wait = 50 secs with 10 cars in line; phase B wait = 80 secs with 7 cars in line. <math>80 \times 7 (560) &gt; 50 \times 10 (500)</math> so Phase B is selected.</p> <p><b>Note</b> • Also, to include a phase in the selection process, you must set <b>PMT QUEUE DELAY</b> to <b>YES</b> in MM-6-2.</p>	OFF, ON, TOD

- Preempt Plans 1-10, MM-4-1

MM-4-1 Parameter	Description	Range
<b>Preemptor Exit Phases, continued</b>		
<p>EXIT OPT</p> <p>This parameter is several lines higher in MM-4-1 (refer to Line 22, page 9-4) but is included here because it sets a preemptor exit phase.</p>	<p><b>Preemption Exit Options for Timing Plan</b></p> <p><b>Note</b> • In the descriptions below, “Timing Plan” refers to the Timing Plan set in X TMG PLN (the prompt that follows EXIT OPT). For XPH and CYC to operate, you must set a Timing Plan (1, 2, 3 or 4). CRD, however, operates with or without a Timing Plan.</p> <p>Toggle to select the next phase after exit from a preemptor:</p> <p><b>OFF:</b> Disable</p> <p><b>CRD:</b> The preemptor exits directly into the coordination sequence and does not require a pickup cycle when the coordinator is active.</p> <p><b>XPH:</b> The preemptor exits directly to the exit phase with a Timing Plan. This preempt exit Timing Plan is used only for the timing of the exit phases.</p> <p><b>CYC:</b> The preemptor exits to Free for <i>one</i> cycle by a Timing Plan. Then the controller will go back to running Coordination.</p>	<p>OFF, CRD, XPH, CYC</p>
<p>X TMG PLN</p> <p>This parameter is several lines higher in MM-4-1 (refer to Line 23, page 9-4) but is included here because it sets the timing plan for a preemptor exit phase.</p>	<p><b>Preemption Exit Timing Plan</b></p> <p>Select the controller timing plan (MM-2-1) that will be in effect when exiting preemption.</p> <p><b>1-4:</b> Forces the controller to use selected timing plan for the first controller cycle following preemption. That controller cycle will be complete when all phases have been served that had demand when exiting preemption.</p> <p><b>0 (zero):</b> Lets you select the timing plan by normal controller operation.</p> <p><b>Note</b> • If the preemptor exits directly to coordination (Preemption to Coordination), the timing plan selected by the preemptor will be in effect as coordination is running until all phases with demand at preempt exit have been serviced.</p>	<p>0-4</p>

MM-4-1 Parameter	Description	Range
<b>Preemptor Exit Phases, continued</b>		
PR RTN%	<p><b>Vehicle Priority Return Green Percent Values</b></p> <p><b>Note</b> • Interrupted Phases = phases timing when the preemptor tries to start.</p> <p>Enter the minimum percent of green that is necessary to time in an Interrupted Phase:</p> <p><b>0:</b> Disables</p> <p><b>1 - 100:</b> For an Interrupted Phase, minimum % of green to time</p> <p>When you enter a % value (1-100), the preemptor:</p> <ol style="list-style-type: none"> <li><b>1</b> Calculates the % Green timed of the Interrupted Phase.</li> <li><b>2</b> Compares the % Green timed with the % value you entered for this parameter for that phase.</li> <li><b>3</b> If the % Green is <i>less than</i> the % value you entered for this phase, then selects that Interrupted Phase as a Veh Priority Return Exit phase.</li> </ol>	0 - 100
<b>Preemptor Entry Timing</b>		
COND DELAY	<p><b>Conditional Delay Entrance Option</b></p> <p>Toggle to enable/disable the conditional delay to determine whether or not to apply omits to movements, as explained below:</p> <p><b>OFF:</b> Disabled</p> <p><b>ON:</b> Enabled ALWAYS</p> <p><b>TOD:</b> Enabled only by Time-of-Day (TOD)</p> <p>When this is enabled, and a preempt is activated, the preemptor compares its delay time to the minimum time required to service phase and pedestrian movements. If the amount of time left in the delay timer is <i>less</i> than the amount required to service a phase or ped, then the preemptor will apply omits to those movements.</p> <p>When all phases have been omitted due to lack of time, the preemptor will direct the controller to the preempt Entry Phases so it can start the preempt as soon as the Delay Timer reaches 0 (zero).</p>	OFF, ON, TOD

Preempt Filtering & TSP/SCP Mapping, MM-4-2

```

ENABLE PREEMPT FILTERING & TSP/SCP
FILTERED      SOLID      PULSING
INPUT  1  ...BYPASSED...  ...BYPASSED...
        2  ...BYPASSED...  ...BYPASSED...
        3  ..PREEMPT  3.  ..PREEMPT  7.
        4  ..PREEMPT  4.  ..PREEMPT  8.
        5  ..PREEMPT  5.  ..PREEMPT  9.
        6  ..PREEMPT  6.  ..PREEMPT 10.
        7  ...BYPASSED...  ...BYPASSED...
        8  ...BYPASSED...  ...BYPASSED...
        9  ...BYPASSED...  ...BYPASSED...
       10  ...BYPASSED...  ...BYPASSED...
    
```

**To select active low priority preemptors that will respond to a delayed pulsing or solid input:**

- ▶ Use Toggle, **0/YES**. The delay is caused by the input filtering required to discriminate between a solid and a 6.25 Hz input on the same input.
- ▶ Use Solid typically for emergency vehicle preemptors (EVP) and Pulsing for bus preemptors in Transit Signal Priority (TSP).

MM-4-2 Parameter	Description	Range
FILTERED INPUT	<b>Physical Preemptor 1-10 inputs</b>	
SOLID	<p><b>Solid Filtered Input</b> (ECPI feature for single-pulse and SOLID, signals)</p> <p>Range:                      BYPASSED, PREEMPT 1-10                      TSP/SCP IN 1-6, TSP/SCP OUT 1-6</p> <p>Toggle to select type:  <b>BYPASSED:</b> Filtering is bypassed for this input and it connects directly to the preemptor of the same number. Use this for the highest priority preempt, such as a train. For the bypass option to work, both columns (SOLID and PULSING) must be set with BYPASSED option.</p> <p><b>Note</b> • <i>For High Priority Preempt, the RE-SERV time (Re-service Time) and the MX TM (Maximum Preempt Call Time) are ignored for a High Priority Preempt (these times are set in MM-4-1).</i></p>	BYPASSED, PREEMPT 1-10, TSP/SCP IN 1-6, TSP/SCP OUT 1-6



MM-4-2 Parameter	Description	Range
SOLID (cont.)	<p><b>Solid Filtered Input</b></p> <p><b>PREEMPT 1-10:</b> Filters a SOLID input and maps the output to the preempt number selected. These are often used for Emergency Vehicle Preempts.</p> <p><b>Note</b> • <i>For Low Priority Preempt:</i> The priority of a preempt is determined in MM-4-2. For an input in MM-4-2, if either or both of the columns (SOLID and PULSING) do NOT have a BYPASSED entry, then the input is Low Priority. Low Priority Preempts honor both RE-SERV (Re-service Time) and the MX TM (Maximum Preempt Call Time). Be cautioned that a RE-SERV time of ZERO disables the Re-service Interval. Refer to <i>Low Priority Preemption Re-service Time</i> on page 9-18, a parameter in MM-4-1, for details.</p> <p><b>Note</b> • <i>For TSP/SCP:</i> In MM-4-3, for each TSP/SCP PLAN with SOLID signals, set DET SIGNAL = SOLID. If DET SIGNAL = PULSING, then these signals would not be connected.</p> <p><b>TSP/SCP IN 1-6:</b> Maps a SOLID TSP/SCP Check-In signal.</p> <p><b>TSP/SCP OUT 1-6:</b> Maps a SOLID TSP/SCP Check-Out signal.</p> <p><b>IMPORTANT</b> • In MM-4-3, for each TSP/SCP PLAN with SOLID signals, set SIGNAL TYPE = S. If SIGNAL TYPE = P, then these signals would not be connected.</p>	BYPASSED, PREEMPT 1-10, TSP/SCP IN 1-6, TSP/SCP OUT 1-6
PULSING	<p><b>Pulsing Filtered Input</b></p> <p>(ECPI &amp; NTCIP feature for PULSING signals)</p> <p>Range: BYPASSED, PREEMPT 1-10, TSP/SCP 1-6</p> <p>Toggle to select type:</p> <p><b>BYPASSED:</b> Filtering is bypassed for this input and it connects directly to the preemptor of the same number. Use this for the highest priority preempt, such as a train.</p> <p><b>PREEMPT 1-10:</b> Filters a PULSING input and maps the output to the preempt number selected.</p> <p><b>TSP/SCP 1-6:</b> Maps a PULSING TSP/SCP Signal.</p> <p><b>IMPORTANT</b> • In MM-4-3, for each TSP/SCP PLAN with PULSING signals, set SIGNAL TYPE = P. If SIGNAL TYPE = S, then these signals would <i>not</i> be connected.</p>	BYPASSED, PREEMPT 1-10, TSP/SCP 1-6

- TSP/SCP Plans 1-6, MM-4-3

### TSP/SCP Plans 1-6, MM-4-3<sup>1</sup>

```

TSP/SCP PLAN
  TSP/SCP PLAN      1    2    3    4    5    6
TSP/SCP ENA        T1  T2    .    .    .    .
SIGNAL TYPE        P    P    P    P    P    P
DET LOCK           .    .    .    .    .    .
DELAY TIME         XXX  XXX  XXX  XXX  XXX  XXX
MAX PRESENCE       0    0    0    0    0    0
PMT ENA RESERVE   X    X    X    X    X    X
NO DELAY IN TSP   X    X    X    X    X    X
ACT SF INHIBIT    0    0    0    0    0    0
RESERVE CYCLS     0    0    0    0    0    0
BUS HEADING        NB  SB   EB  WB
TSP OR SCP.... TSP FREE DEFAULT PLAN.120
HEADWAY ALLOWANCE 100%

      ----- TSP/SCP PHASE -----
      1 2 3 4 5 6 7 8 9 0 1 2 3 4 5 6
TSP/SCP1 . T . P . T . P . . . . . . . . . .
TSP/SCP2 . . V T . . V T . . . . . . . . . .
TSP/SCP3 . . . . . . . . . . . . . . . . . .
TSP/SCP4 . . . . . . . . . . . . . . . . . .
TSP/SCP5 . . . . . . . . . . . . . . . . . .
TSP/SCP6 . . . . . . . . . . . . . . . . . .
    
```

### TSP/SCP Split Pattern, MM-4-4

**Note** • In MM-4-4, if the mode is TSP, the MAX EXTN (maximum extension) parameter is *not* shown. This is only shown if you select the SCP mode.

```

TSP/SCP SPLIT PATTERN [ 1 ]
IN EFFECT TMG PLAN [1] 0 SPL DM [0] 0
  PHASE  1  2  3  4  5  6  7  8
MAX RDTN.255 255 255 255 255 255 255 255
MIN GRN..  5  5  5  5  5  5  5  5
MAX EXTN.255 255 255 255 255 255 255 255

  PHASE  9 10 11 12 13 14 15 16
MAX RDTN.255 255 255 255 255 255 255 255
MIN GRN..  5  5  5  5  5  5  5  5
MAX EXTN.255 255 255 255 255 255 255 255
    
```

**When in a hyperlink field:**

**To follow the hyperlink:**

For ASC/3, press **SPEC FUNC**, then **NEXT DATA**.

For 2070, press **B**.

**To go back:**

For ASC/3, press **SUB MENU**.

For 2070, press **ESC**.

<sup>1</sup> For instructions to enter data in MM-4-3 and MM-4-4, refer to the *Transit Signal Priority (TSP) User Guide for Advanced System Controllers ASC/3*, P/N 100-0903-003.

## Time Base

### Time Base Submenu, MM-5

#### Programming Summary

<p>TIME BASE SUBMENU</p> <ol style="list-style-type: none"> <li>1. CLOCK/CALENDAR DATA</li> <li>2. ACTION PLAN</li> <li>3. DAY PLAN/EVENT</li> <li>4. SCHEDULE NUMBER</li> <li>5. EXCEPTION DAYS</li> </ol>
---

A brief description follows of the programming functions that can be viewed and/or changed at each of the menu options.

MM-5 Menu Option	Programming Summary
1. CLOCK/CALENDAR DATA	<ul style="list-style-type: none"> <li>■ View current day of week, time, day and date.</li> <li>■ Enter current date and time.</li> <li>■ Enter manual Action Plan to override other action plans.</li> <li>■ Enter synchronization reference time.</li> <li>■ Select the synchronization reference type.</li> <li>■ Enable/Disable Daylight Savings time correction.</li> <li>■ Select the time that the “Time Reset” input will set the clock to.</li> <li>■ Enter the number of hours that local standard time is behind GMT.</li> </ul>

▪ Programming Summary

MM-5 Menu Option	Programming Summary
2. ACTION PLAN	<p>You can define up to 100 Action Plans.</p> <p><b>Assign:</b></p> <ul style="list-style-type: none"> <li>■ Coordination pattern number</li> <li>■ Vehicle detector plan number</li> <li>■ Controller sequence</li> <li>■ Timing plan</li> <li>■ Vehicle detector diagnostic plan</li> <li>■ Pedestrian detector diagnostic plan</li> </ul> <p><b>Enable:</b></p> <ul style="list-style-type: none"> <li>■ Automatic flash</li> <li>■ System override</li> <li>■ Detector log</li> <li>■ Dimming</li> <li>■ Special functions</li> <li>■ Auxiliary functions</li> <li>■ Phase functions:                             <ul style="list-style-type: none"> <li>● Pedestrian recall</li> <li>● Walk 2 enable</li> <li>● Vehicle extension 2 enable</li> <li>● Vehicle recall</li> <li>● Vehicle max recall</li> <li>● Max 2 enable</li> <li>● Max 3 enable</li> <li>● Conditional service inhibit</li> <li>● Phase omit</li> </ul> </li> </ul>
3. DAY PLAN/EVENT	<p>You can select the start time for one of 100 action plans for one of 50 day plans that comprise each of 16 day plans.</p>

MM-5 Menu Option	Programming Summary
4. SCHEDULE NUMBER	You can set up Day Plan schedules. Set up a schedule of 200 entries of: <ul style="list-style-type: none"> <li>■ One of 16 day plans</li> <li>■ Month(s) in effect</li> <li>■ Day(s) of month(s) in effect</li> <li>■ Day(s) or the week in effect</li> </ul>
5. EXCEPTION DAYS	<ul style="list-style-type: none"> <li>■ Select unique day plan for up to 36 exception days.</li> <li>■ Select fixed or floating holidays.</li> <li>■ Identify holidays by date, day of week or week of month.</li> </ul>

### Clock/Calendar Data, MM-5-1

```

CLOCK/CALENDAR DATA
03/05/2012          MON          07:31:23
ENA ACTION PLAN.  0
SYNC REF TIME.00:00 SYNC REF..  REF TIME
TIME FROM GMT...-04 DAY LIGHT SAVE.USDL$
TIME RESET INPUT SET TIME..... 03:30:00
  
```

#### To set the date/time:

- ▶ Enter or change date and time.
- ▶ Correct the date and time as necessary for accurate controller operation in non-interconnected mode.
- ▶ At any time when the cursor is at a time or date field, to update the time or date to whatever is shown on the screen in the date and time fields, press **ENTER**.

#### To enable an action plan:

- 1 Manually select an action plan.
- 2 Go to ACTION PLAN screen (MM-5-4) and create desired program to be in effect when the manual program is selected.

The manually-selected action plans go into effect on the minute's boundaries.

## Time Base

- *Clock/Calendar Data, MM-5-1*

MM-5-1 Parameter	Description	Range
XX/XX/XXXX	<p><b>Date Set</b></p> <p>Use the numeric keys (0-9) to enter the current date in MM/DD/YY format.</p> <p><b>Note</b> • The display of the day of the week (DOW) is automatically generated from this entry.</p>	01/01/1970 – 12/31/2105
XX:XX:XX	<p><b>Time Set</b></p> <p>Use the numeric keys (0-9) to enter the current time of day (TOD) in the 24-hour format (00:00:00 to 23:59:59).</p> <p>This time is used for all time-based functions and logging.</p>	00:00:00 – 23:59:59
ENA ACTION PLAN	<p><b>Enable Action Plan</b></p> <p>Use the numeric keys (0-9) to select an Action Plan (ref. MM-5-4) that specifies a coordination pattern. The Action Plan remains in effect until another Action Plan is selected or until zero is entered.</p> <p><b>0</b> (zero): Allows the automatic selection of Time Base Action Plans by time of day.</p> <p><b>1-100</b>: Manually selects that Action Plan to be in effect. The selected Action Plan remains in effect until another is selected.</p> <p><b>Note</b> • Manual selection overrides any other source. Manual Pattern (MM-3-1) overrides Manual Action plan.</p>	0-100
SYNC REF TIME	<p><b>Synchronization Reference Time</b></p> <p>Use the numeric keys (0-9) to enter the time (in 24-hour format) that is a user-specified time marking the beginning of all cycles. Reference time is used for sync point calculation for a cycle called by the coordination pattern. Sync point is computed using present time, sync reference time, and current cycle length.</p> <p>This sync reference time is used when:</p> <ul style="list-style-type: none"> <li>■ Reference Time is selected as Synchronization Reference.</li> <li>■ Time Base is the interconnect source, either by default or by selection.</li> </ul> <p><b>Note</b> • A sync pulse is generated when the present time minus this time is an even multiple of the coordinator cycle length.</p>	00:00 – 23:59

MM-5-1 Parameter	Description	Range
SYNC REF	<p><b>Synchronization Reference</b></p> <p>Use Toggle, <b>0/YES</b>, to select the type of reference (LAST EVENT, LAST SYNC, or REFERENCE TIME) to be used as the reference point for the sync generation.</p> <p><b>REFERENCE TIME:</b> Sync point is the sync reference time entered by user.</p> <p><b>LAST EVENT:</b> Sync point is referenced to the time of the action plan that initiated the current cycle.</p> <p><b>LAST SYNC:</b> Sync point is referenced to the point in time that represents the end of the last complete cycle of the cycle length in effect prior to selecting the current cycle length.</p> <p><b>Note</b> • A sync pulse is generated when the present time minus the <b>SYNCHRONIZATION REFERENCE</b> time is an even multiple of the coordinator cycle length.</p>	Last Event, Last Sync, Reference Time
TIME FROM GMT	<p><b>Standard Local Time from GMT</b></p> <p>Toggle to specify the number of hours (-12 to +12) that the local standard (non daylight savings time) is ahead (+) or behind (-) Greenwich Mean Time (GMT).</p> <p>The Eastern hemisphere is ahead (+) and the Western hemisphere is behind (-).</p> <p><b>Note</b> • For Non Day Time Saving, observe the differences in time zones listed below.</p> <p>USA Eastern Time Zone is GMT -5 hours.</p> <p>USA Central Time Zone is GMT -6 hours.</p> <p>USA Mountain Time Zone is GMT -7 hours.</p> <p>USA Pacific Time Zone is GMT -8 hours.</p>	-12 to +12

▪ *Creating an Action Plan, MM-5-2*

MM-5-1 Parameter	Description	Range
DAY LIGHT SAVE	<b>Enable Daylight Savings Time Adjustment</b> Toggle to enable (USDLS) or disable (NO) United States Daylight Savings time adjustment.  Enables daylight savings to be enabled from the second Sunday of March to the first Sunday of November.	USDLS enable  NO disable
TIME RESET INPUT	Use the numeric (0-9) keys to enter a time of day value (00:00:00 to 23:59:59).  The controller internal time will be set to this value when the TIME RESET input is TRUE. The internal time starts when the TIME RESET input is removed.	00:00:00 to 23:59:59

*Creating an Action Plan, MM-5-2*

Use this screen (with vertical scrolling) to select an Action plan for viewing or editing and provide data entry fields to program the plan for appropriate actions.

Action plans are created to select the coordination pattern, and to enable various functions by time of day. Up to 100 action plans are available. Daily programs may contain any number of action plan steps up to available limit.

```

ACTION PLAN...[ 1]
PATTERN.....AUTO  SYS OVERRIDE....YES
TIMING PLAN..... 0  SEQUENCE..... 0
VEH DETECTOR PLAN. 0  DET LOG.....NONE
FLASH..... EN RED REST.....YES
VEH DET DIAG PLN.. 0  PED DET DIAG PLN..0
DIMMING ENABLE.. NO

      PHASE 1 2 3 4 5 6 7 8 9 0 1 2 3 4 5 6
PED RCL . . . . .
WALK 2 . . . . .
VEX 2 . . . . .
VEH RCL . . . . .
MAX RCL . . . . .
MAX 2 X X X X X X X X . . . . .
MAX 3 . . . . .
CS INH . . . . .
OMIT . . . . .
SPC FCT . . . . . (1-8)
AUX FCT . . . (1-3)
      1 2 3 4 5 6 7 8 9 0 1 2 3 4 5
LP 1-15 . . . . .
LP 16-30 . . . . .
LP 31-45 . . . . .
LP 46-60 . . . . .
LP 61-75 . . . . .
LP 76-90 . . . . .
LP91-100 . . . . .
    
```

**When in a **hyperlink** field:**

**To follow the hyperlink:**

For ASC/3, press **SPEC FUNC**, then **NEXT DATA**.

For 2070, press **B**.

**To go back:**

For ASC/3, press **SUB MENU**.

For 2070, press **ESC**.



## Action Plan Functions

### Assign:

- Coordination pattern number
- Vehicle detector plan number
- Controller sequence
- Timing plan
- Vehicle detector diagnostic plan
- Pedestrian detector diagnostic plan

### Enable:

- Automatic flash
- System override
- Detector log
- Dimming
- Special function outputs
- Auxiliary function outputs
- By-Phase functions:
  - Pedestrian recall
  - Walk 2 enable
  - Vehicle extension 2 enable
  - Vehicle recall
  - Vehicle max recall
  - Max 2 enable
  - Max 3 enable
  - Conditional service inhibit
  - Phase omit
- Logic Processor (LP) Statements (1-100)

- *Creating an Action Plan, MM-5-2*

<b>MM-5-2 Parameter</b>	<b>Description</b>	<b>Range</b>
ACTION PLAN	<p><b>Action Plan Number</b></p> <p>Use the numeric (0-9) keys to specify the Action Plan (1-100) to be viewed or edited.</p>	1-100 selects plan
PATTERN	<p><b>Coordination Pattern Selected by the Action Plan</b></p> <p>Use the numeric (0-9) keys to enter the Coordination Pattern number used by this Action Plan.</p> <p><b>0</b> (zero): Indicates that no pattern is being selected. The Time Base relinquishes control and allows lower priority control (i.e., hardware interconnect if available).</p> <p><b>1-120</b>: Selects the coordination pattern for this Action Plan.</p> <p><b>254</b>: Selects FREE operation. Sequence defaults to 1 if not specified.</p> <p><b>255</b>: Selects automatic FLASH operation. Same as Enabling FLASH below. AUTOMATIC FLASH pattern is treated in the same priority as any other pattern.</p> <p><b>Note</b> • <b>Selecting a pattern that does not exist or does not meet the timing parameters will set the controller to FREE.</b></p>	0, 1-120, 254, 255
SYS OVERRIDE	<p><b>System Override</b></p> <p>Toggle to enable (YES) or disable (NO) the Time Base Coordination Pattern to override system commands.</p> <p><b>YES</b>: Coordination Pattern selected by the Action Plan overrides the pattern selected by current telemetry or hardwired system commands.</p> <p><b>NO</b>: Coordination Pattern selected by the Day Plan Event does not override the pattern selected by telemetry or hardwired system commands.</p>	YES enable  NO disable

MM-5-2 Parameter	Description	Range
TIMING PLAN	<p><b>Timing Plan</b></p> <p>Use the numeric (0-9) keys to select the Timing Plan (1-4) when a higher priority routine has not selected one.</p> <p><b>0</b> (zero): Allows the Timing Plan in effect to be used.</p> <p><b>1-4</b>: Selects the timing plan.</p> <p><b>Note</b> • <b>The priorities (from highest to lowest) are listed below.</b></p> <ul style="list-style-type: none"> <li><b>1</b> Manual</li> <li><b>2</b> Preemptor</li> <li><b>3</b> System</li> <li><b>4</b> Coordinator</li> <li><b>5</b> Hardware</li> <li><b>6</b> Time Base</li> </ul> <p>If the PATTERN field on MM-5-2 (ACTION PLAN) is selected, and if the selected PATTERN (MM-3-2) has a timing plan programmed, then this field will be read-only. The Timing Plan in MM-3-2 overrides this field.</p>	0-4

- *Creating an Action Plan, MM-5-2*

MM-5-2 Parameter	Description	Range
SEQUENCE	<p><b>Controller Sequence</b></p> <p>Selects the controller sequence to operate.</p> <p>Selects the controller sequence, for this Action Plan, when a higher priority routine has not made a selection. Selection priorities, from highest to lowest are: Manual, System, Coordinator, Hardware and Time Base.</p> <p><b>0</b> (zero): Sequence selection is by other means (hardware inputs or Time Base). Defaults to 1 if no sequence number is specified anywhere else.</p> <p><b>1-16</b>: Selects one of 16 possible configurations of sequence data (refer to NTCIP 1202, 2.8.3.3).</p> <p>For sequences 17 thru 20, refer to Appendix Q, <i>Diamond Intersection Application Notes</i>. The pre-programmed sequences for Diamond Intersections are for user-specific requirements that exceed NEMA or NTCIP specifications.</p> <p><b>17-20</b>: Selects one of 4 pre-programmed controllers (Econolite feature), each with one pre-programmed sequence.</p> <ul style="list-style-type: none"> <li>■ 17 = Diamond 4-Phase controller</li> <li>■ 18 = Diamond 3-Phase controller</li> <li>■ 19 = Diamond Separate Intersection controller</li> <li>■ 20 = Diamond NEMA controller (8 phase Standard Quad)</li> </ul> <p>If the PATTERN field on MM-5-2 (ACTION PLAN) is selected, and if the selected PATTERN (MM-3-2) has the sequence field programmed, then this field will be read-only. The sequence field in MM-3-2 overrides this field.</p>	0-20
VEH DETECTOR PLAN	<p><b>Vehicle Detector Recall Plan</b></p> <p>Use the numeric (0-9) keys to enter the Vehicle Detector Recall Plan number (0-4) to be applied by this Action Plan.</p> <p><b>0</b> (zero): Allows the Day Plan Event to use the Vehicle Detector Plan already in effect.</p> <p><b>1-4</b>: Selects the vehicle detector plan when a higher priority routine has not selected one.</p> <p><b>Note</b> • <b>The priorities (from highest to lowest) are: Manual, Preemptor, System, Coordinator, Hardware, and Time Base.</b></p>	0-4

MM-5-2 Parameter	Description	Range
DET LOG	<p><b>Internal Detector Log Enable</b></p> <p>Toggle to select NONE, 5, 15, 30, or 60 minutes detector logging.</p> <p><b>Note</b> • This selection is only in effect when the ECPI LOG Period in Log-Speed Detector Setup (MM-6-4) is set to TBAP.</p>	NONE, 5, 15, 30, 60
FLASH	<p><b>Automatic Flash</b></p> <p>Toggle to enable (YES) or disable (NO) the request for Automatic Flash by this Action Plan. This is the same as setting coord pattern to 255 above.</p> <p><b>Note</b> • This request is “OR’ed” with all other requests for automatic flash.</p>	YES enable NO disable
RED REST	<p><b>Red Rest (Call Away)</b></p> <p>Toggle, 0/YES, enable (YES) or disable (NO) the request for Red Rest (Call Away) operation by this Action Plan.</p> <p><b>Note</b> • This request is “OR’ed” with all other requests for Red Rest.</p>	YES enable NO disable
VEH DET DIAG PLN	<p><b>Vehicle Detector Diagnostic Plan</b></p> <p>Use the numeric (0-9) keys to select the vehicle detector diagnostic plan by this Action Plan if one has not been selected.</p> <p><b>0</b> (zero): No vehicle detector diagnostic is selected.</p> <p><b>1-4</b>: Selects the vehicle detector diagnostic plan if a higher priority routine has not already selected one.</p> <p><b>Note</b> • The priorities (from highest to lowest) are: Manual, Hardware, and Time Base.</p>	0 no diagnostic selected  1-4 selects by priority.
PED DET DIAG PLN	<p><b>Pedestrian Detector Diagnostic Plan</b></p> <p>Selects the Pedestrian Detector Diagnostic Plan if one has not been selected. Use the numeric (0-9) keys to enter the number (0-4) of the diagnostic plan.</p> <p><b>0</b> (zero): No pedestrian detector diagnostic is selected.</p> <p><b>1-4</b>: Selects the pedestrian detector diagnostic plan when a higher priority routine has not been selected one.</p> <p><b>Note</b> • The priorities (from highest to lowest) are: Manual, Hardware, and Time Base.</p>	0-4

- *Creating an Action Plan, MM-5-2*

MM-5-2 Parameter	Description	Range
DIMMING ENABLE	<p><b>Dimming Enable</b></p> <p>Toggle to enable (YES) or disable (NO) dimming by this Action Plan.</p> <p>Dimming of the signals also requires:</p> <ul style="list-style-type: none"> <li>▪ Dimming input is TRUE.</li> <li>▪ Dimming polarity is programmed (MM-1-3).</li> </ul>	YES/NO
PED RCL	<p><b>Pedestrian Recall</b></p> <p>Toggle to enable (X) or disable (“.”) application of Pedestrian Recall by this Action Plan.</p> <p><b>X:</b> Enables, but is “OR’ed” with other Pedestrian Recall programming and inputs.</p> <p>“.”: Disables pedestrian recall by this Action Plan.</p>	X enable “.” disable
WALK 2	<p><b>Walk 2</b></p> <p>Toggle to enable (X) or disable (“.”) application of Walk 2 by this Action Plan.</p> <p><b>X:</b> Enables, but is “OR’ed” with other Walk 2 selections and inputs.</p> <p>“.”: Disables Walk 2 by this Action Plan.</p>	X enables “.” disables
VEX 2	<p><b>Vehicle Extension 2</b></p> <p>Toggle to enable (X) or disable (“.”) application of Vehicle Extension 2 by this Action Plan.</p> <p><b>X:</b> Enables, but is “OR’ed” with other Vehicle Extension 2 selections and inputs.</p> <p>“.”: Disables Vehicle Extension 2 by this Action Plan.</p>	X enables “.” disables
VEH RCL	<p><b>Vehicle Recall</b></p> <p>Toggle to enable (X) or disable (“.”) application of Vehicle Recall by this Action Plan.</p> <p><b>X:</b> Enables, but is “OR’ed” with other Vehicle Recall selections and inputs.</p> <p>“.”: Disables Vehicle Recall by this Action Plan.</p>	X enables “.” disables

MM-5-2 Parameter	Description	Range
MAX RCL	<p><b>Maximum Recall</b></p> <p>Toggle to enable (X) or disable (“.”) application of Max Recall by this Action Plan.</p> <p><b>X:</b> Enables, but is “OR’ed” with other Max Recall selections and inputs.</p> <p><b>“.”:</b> Disables Max Recall by this Action Plan.</p>	X enables “.” disables
MAX 2	<p><b>Max 2</b></p> <p>Toggle to enable (X) or disable (“.”) application of Max 2 by this Action Plan.</p> <p><b>X:</b> Enables, but is “OR’ed” with other Max selections and inputs.</p> <p><b>“.”:</b> Disables Max 2 by this Action Plan.</p> <p><b>Note • Overrides are as listed below:</b></p> <p style="padding-left: 40px;">MAX 2 selection overrides MAX 1.</p> <p style="padding-left: 40px;">MAX 3 selection overrides MAX 1 &amp; 2.</p>	X enables “.” disables
MAX 3	<p><b>Max 3</b></p> <p>Toggle to enable (X) or disable (“.”) application of Max 3 by this Action Plan.</p> <p><b>X:</b> Enables, but is “OR’ed” with other Max selections and inputs.</p> <p><b>“.”:</b> Disables Max 2 by this Action Plan.</p> <p><b>Note • MAX 3 selection overrides MAX 1 or 2.</b></p>	X enables “.” disables
CS INH	<p><b>Conditional Service Inhibit</b></p> <p>Toggle to enable (X) or disable (“.”) application of Conditional Inhibit by this Action Plan.</p> <p><b>X:</b> Enables, but is “OR’ed” with other Conditional Service Inhibit selections and inputs.</p> <p><b>“.”:</b> Disables Conditional Inhibiting by this Action Plan.</p>	X enables “.” disables
OMIT	<p><b>Phase Omit</b></p> <p>Toggle to enable (X) or disable (“.”) application of Phase Omit by this Action Plan.</p> <p><b>X:</b> Enables, but is “OR’ed” with other Phase Omit selections and inputs.</p> <p><b>“.”:</b> Disables Phase Omit by this Action Plan.</p>	X enables “.” disables

**Time Base**

▪ *Creating a Day Plan, MM-5-3*

<b>MM-5-2 Parameter</b>	<b>Description</b>	<b>Range</b>
SPC FCT(1-8)	<b>Special Function 1-8</b> Toggle to enable (X) or disable (“.”) Time Base Special Function 1-8 outputs by this Action Plan.	X enables “.” disables
AUX FCT(1-3)	<b>Auxiliary Function 1-3</b> Toggle to enable (X) or disable (“.”) Time Base Auxiliary Function 1-3 outputs by this Action Plan.	X enables “.” disables
LP 1-100	<b>Action Plan Logic Processor Statements</b> Toggle to enable (E), disable (D), or let others (“.”) determine. <b>E:</b> Allows the logic processor statement to be evaluated unless a higher priority command is in effect. <b>D:</b> Disallows the Logic Processor Statement from being evaluated unless a higher priority command is in effect. <b>“.”:</b> Allows the evaluation of a Logic Processor Statement to be determined by lower priority command.	E enables  D disables  “.” others

*Creating a Day Plan, MM-5-3*

DAY PLAN [ 1]	DAY PLAN IN EFFECT [ 0] v	START TIME
EVENT	ACTION PLAN	START TIME
1	0	00:00
2	0	00:00
3	0	00:00
4	0	00:00
5	0	00:00
6	0	00:00
7	0	00:00
8	0	00:00
9	0	00:00
10	0	00:00
11	0	00:00
12	0	00:00
13	0	00:00
//		
50	0	00:00

Use this screen to create up to 16 Day Plan events that select Action Plans during different times of the day.



**To create daily programs in the time base:**

- 1** Enter the desired Day Plan number (1-16) to be in effect for this time of day.
- 2** Position the cursor in the ACTION PLAN column opposite the EVENT number (1-50) to be programmed.
- 3** Enter the Action Plan number (1-100) that is to be in effect.
- 4** Enter the desired start time (00:00 to 23:59) for this Day Plan Event.

MM-5-3 Parameter	Description	Range
DAY PLAN	Use the numeric keys (0-9) to enter the number (1-16) of the Day Plan to be created.  <b>Note</b> • If an invalid number is entered (not within 1-16 range), an INVALID DATA notice appears when the cursor leaves the field. Use the UP cursor key to return to the Day Plan field and enter a valid number.	1-16
DAY PLAN IN EFFECT	This is not a data entry field. This field displays a number (0-16) indicating the number of the Day Plan that is currently in effect, if any. Zero (0) indicates no Day Plan is in effect.	0-16 display
EVENT	<b>Day Plan Event</b>  With the cursor in the ACTION PLAN column, scroll DOWN as needed until the cursor is directly opposite the Day Plan EVENT number (1-50) to be viewed or edited.  <b>1-50:</b> Selects that Day Plan Event to view or edit. A day event is activated when: <ul style="list-style-type: none"> <li>■ The Day Plan is in effect;</li> <li>■ The current time matches with the programmed start time;</li> </ul> or <ul style="list-style-type: none"> <li>■ The programmed start time is between the day plan previously selected and the current time.</li> </ul>	1-50 selects specified event

- Day Plan Schedule, MM-5-4

MM-5-3 Parameter	Description	Range
ACTION PLAN	<p><b>Action Plan Number</b></p> <p>Use the numeric (0-9) keys to enter an Action Plan Number (1-100).</p> <p><b>1-100:</b> Assigns the action plan to be commanded when this day plan event is in effect.</p>	1-100 selects specified plan
START TIME	<p><b>Day Plan Event Start Time</b></p> <p>Use the numeric (0-9) keys to enter the Start Time (00:00 to 23:59) for the Day Plan. Once selected, the Day Plan will stay in effect until another Day Plan Event is selected.</p> <p><b>Note</b> • <b>Changing HH:MM will force transaction mode to make sure the entire time is entered before committing. Accepting time change on each field may cause an action plan to take effect unintentionally.</b></p>	00:00 to 23:59

Day Plan Schedule, MM-5-4

```

SCHEDULE NUMBER [ 1]
DAY PLAN NO ..... 0 CLEAR ALL FIELDS.. X
SELECT ALL MONTHS.. . DOW.. . DOM.. .
MONTH      J F M A M J J A S O N D
          . . . . .
DAY (DOW) : SUN MON TUE WED THU FRI SAT
          . . . . .
DAY (DOM) :1  2  3  4  5  6  7  8  9 10 11
          . . . . .
          12 13 14 15 16 17 18 19 20 21 22
          . . . . .
          23 24 25 26 27 28 29 30 31
          . . . . .
    
```

Use this screen to create up to 200 Day Plan Schedule entries that assign the days and months that a specified Day Plan can be in effect. Use this screen to:

- Create day plan schedule entries.
- Enter desired daily program number (1-16).
- Enter the month(s) of the year that the day program will be in effect.
- Enter the day(s) of the week that the day program will be in effect.
- Enter the day(s) of the month that the day program will be in effect.

**Note** • A day plan will only be in effect the months that the day of week (DOW) corresponds to the day of month (DOM). However, EXCEPTION DAY programming (MM-5-5) overrides this selection.

**Example:** Day Plan 15 is to be in effect during summer break from June 15 to September 3 on Monday through Friday. Program as follows:

*Schedule 1:* Day plan 15 with the month of June (JUN), days of the week Monday through Friday (MON – FRI) and days of the month 15 – 30 enabled.

*Schedule 2:* Day plan 15 with the months of July and August (JUL - AUG), days of the week Monday through Friday (MON – FRI) and days of the month 1 – 31 enabled.

*Schedule 3:* Day plan 15 with the month of September (SEP), days of the week Monday through Friday (MON – FRI) and days of the month 1 – 3 enabled.

MM-5-4 Parameter	Description	Range
SCHEDULE NUMBER	<p><b>Time Base Schedule Program Number</b></p> <p>Use the numeric (0-9) keys to enter number of the Time Base Schedule program to be viewed and/or edited.</p> <p><b>0</b> (zero): Selects the next open Time Base Schedule program.</p> <p><b>1-200:</b> Specifies the Time Base Schedule Program Number to be viewed or edited.</p>	0-200
DAY PLAN NO.	<p><b>Use the numeric (0-9) keys to enter the Day Plan Number</b></p> <p><b>0</b> (zero): Clears all programming of this Time Base Schedule Program.</p> <p><b>1-16:</b> Selects the Day Plan to be in effect when this Time Base Schedule program is in effect.</p>	0 clears schedule  1-16 selects Day Plan
CLEAR ALL FIELDS	<p><b>Clear All Fields</b></p> <p>ECPI Feature</p> <p>TOGGLE to select (X) or deselect (.) to clear all selections on schedule.</p> <p><b>X:</b> Clears all selections on the schedule when you press <b>ENTER</b>. The display will return to the default state (.) after selecting.</p> <p><b>“.”</b> : Does <i>not</i> clear all selections.</p>	X, “.”

**Time Base**

- Day Plan Schedule, MM-5-4

<b>MM-5-4 Parameter</b>	<b>Description</b>	<b>Range</b>
SELECT ALL MONTHS	<p><b>Select All Months</b> ECPI Feature</p> <p>TOGGLE to select (X) or deselect (.) selecting all months on the schedule.</p> <p>X: Selects all months of the schedule when you press <b>ENTER</b>. The display returns to the default state (.) after selecting.</p> <p>“.” : Does not select all months of the schedule.</p>	X, “.”
MONTH	<p><b>Month(s) This Schedule is in Effect</b></p> <p>Use Toggle, <b>0/YES</b>, to enable (X) or disable (“.”) the months that the Schedule program shall be allowed.</p> <p><b>Note</b> • <b>A Time Base Schedule program will be in effect, when it is allowed under the Month, DOW and DOM programming. HOLIDAY programming (MM-5-5) overrides this selection.</b></p>	X enables “.” disables
DAY (DOW)	<p><b>Days of Week (DOW) this Program is in Effect</b></p> <p>Use Toggle, <b>0/YES</b>, to enable (X) or disable (“.”) the day(s) of the week that the Time Base Schedule program shall be allowed.</p>	X enables “.” disables
DAY (DOM)	<p><b>Days of Month (DOM) this Program is in Effect</b></p> <p>Use Toggle, <b>0/YES</b>, to enable (X) or disable (“.”) the date(s) of the month that the Time Base Schedule program shall be allowed.</p>	X enables “.” disables

## Exception Days, MM-5-5

As shown below, scroll through this screen to view or edit the control parameters for up to 36 Exception Days or any day having special traffic demands.

EXCEPTION DAY PROGRAM					
EXCEPTION DAY	FLOAT/ FIXED	MON/ MON	DOW/ DOM	WOM/ YEAR	DAY PLAN
1	FIXED	0	0	0	0
2	FIXED	0	0	0	0
3	FIXED	0	0	0	0
4	FIXED	0	0	0	0
5	FIXED	0	0	0	0
6	FIXED	0	0	0	0
7	FIXED	0	0	0	0
8	FIXED	0	0	0	0
9	FIXED	0	0	0	0
10	FIXED	0	0	0	0
11	FIXED	0	0	0	0
12	FIXED	0	0	0	0
13	FIXED	0	0	0	0
//					
36	FIXED	0	0	0	0

### To program an Exception Day:

- 1** Create a Day Plan (1-16) to be used on an Exception Day.
- 2** Move the cursor up or down the Exception Day column or use the numeric (0-9) keys to select a specific Exception Day number (1-36) to program or edit.
- 3** In the FLOAT/FIXED column, use Toggle, **0/YES**, to select the FLOAT or FIXED parameter for the Exception Day. For more information, refer to *Floating or Fixed Exception Day* on page 10-21.
- 4** In the MON/MON column, enter the number of the month (0 disables or 1-12) in which the Exception Day occurs.
  - For a Floating Exception Day, enter the DOW (day of week, 1-7, Sunday = 1, or 0 disables) and WOM (week of month, 1-5 or 0 disables) on which the Exception Day occurs.
  - For a Fixed Exception Day, enter the DOM (day of month –1-31 or 0 disables) and the Year (1970-2105 or 0 for annually) on which the Exception Day occurs. Once active, the exception day programming will be cleared.
- 5** Enter the number of the Day Plan (1-16 or 0 disables) to be selected on Exception Day specified.

- Exception Days, MM-5-5

---

**Note •** Observe the programming notes listed below:

- The Exception Day program is effective only if Time Base is the command source.
  - DOW = 1 = Sunday.
  - DOW, DOM, WOM, or Day Plan = 0 disables the Exception Day.
  - YEAR = 0 = repeat Exception Day annually.
- 

**FLOAT/FIXED Examples**

**Thanksgiving** is a floating Exception Day. It always occurs on the fourth Thursday in November. It is programmed as follows: FLOAT/FIXED is set to FLOAT, MON/MON is set to 11 for the month of November, DOW/DOM is set to day of the week 5 for Thursday, and WOM/YEAR is set to 4 for the fourth week of the month.

**Independence Day** is a fixed Exception Day. It always occurs on July 4th regardless of the day of the week. It is programmed as follows: FLOAT/FIXED is set to FIXED, MON/MON is set to 7 for July, DOW/DOM is set to 4 for the 4th day of the month, and WOM/YEAR is set to 0 for annually.

MM-5-5 Parameter	Description	Range
EXCEPTION DAY	<p>Move the cursor up and down the Exception Day column to select a specific Exception Day (1-36) to view or edit.</p> <p><b>Note •</b> Observe the programming notes below:</p> <ul style="list-style-type: none"> <li>■ Up to 36 different Exception Days programs can be created.</li> <li>■ The Exception Day program is effective only if Time Base is the command source.</li> <li>■ An Exception Day program overrides the Day Plan program normally used on that specific day.</li> </ul>	1-36

MM-5-5 Parameter	Description	Range
FLOAT/FIXED	<p><b>Floating or Fixed Exception Day</b></p> <p>Use Toggle, <b>0/YES</b>, to select FIXED or FLOAT.</p> <p><b>FLOAT:</b> Occurs on an ordinal numbered (1<sup>st</sup>, 2<sup>nd</sup>, etc.) day-of-the-week (DOW) of a month.</p> <p><b>Note</b> • The WOM is counted from the first week of the month (MON) that contains the DOM. For example, Labor Day for 2006 was September 4. September 4 (1<sup>st</sup> Monday in September) is considered in the 1<sup>st</sup> WOM (even though there were 2 days of September in the previous week).</p> <p><b>FIXED:</b> Occurs on a specific <i>date</i> of the year.</p> <p><b>Note</b> • For the date to apply to all years, enter “0” in the WOM/YEAR field.</p> <p><b>Examples:</b></p> <p><b>FLOAT:</b> Thanksgiving is a floating Exception Day. It always occurs on the 4<sup>th</sup> Thursday in November. To program Thanksgiving (for all years):  “FLOAT”, MON/MON = 11, DOW/DOM = 5, and WOM/YEAR = 4</p> <p><b>FIXED:</b> July 4<sup>th</sup> is a fixed Exception Day. It always occurs on July 4, regardless of the day of the week. To program for year 2007:  “FIXED”, MON/MON = 7, DOW/DOM = 4, and WOM/YEAR = 2007</p> <p>To program for all years:  “FIXED”, MON/MON = 7, DOW/DOM = 4, and WOM/YEAR = 0</p> <p><b>Note</b> • When the current date matches the floating holiday (Month, DOW and WOM) or fixed holiday (Month, DOM and Year), the day plan assigned to the Exception Day plan replaces day plan selected by the Time Base Schedule.</p>	FLOAT or FIXED
MON/MON	<p><b>Month in which Exception Day occurs</b></p> <p><b>1-12:</b> Selects the month in which the Exception Day occurs.</p> <p><b>0 (zero):</b> Disables the Exception Day.</p>	1-12 = Jan-Dec  0 disables

**Time Base**

- *Exception Days, MM-5-5*

<b>MM-5-5 Parameter</b>	<b>Description</b>	<b>Range</b>
DOW/DOM	<p><b>Day of the Week or Day of the Month</b></p> <p><b>1-7:</b> Selects the day of the week (Sunday – Saturday, respectively) for a FLOAT Exception Day.</p> <p><b>1-31:</b> Selects the day of the month for a FIXED Exception Day.</p> <p><b>0 (zero):</b> Disables the Exception Day.</p>	<p>1-7 = Sun-Sat</p> <p>1-31 = DOM</p> <p>0 disables day</p>
WOM/YEAR	<p><b>Week of the Month or Year</b></p> <p><b>1-5:</b> Selects the week of the month for a FLOAT Exception Day.</p> <p><b>1970-2105:</b> Selects the year for the FIXED Exception day.</p> <p><b>0 (zero):</b> Repeats the Exception Day year after year.</p> <p><b>Note • Week of Month (WOM) greater than 5 or Years less than 1970 disable the Exception Day.</b></p> <p><b>Note • Observe the programming notes below:</b></p> <ul style="list-style-type: none"> <li>■ The WOM is counted from the first week of the month (MON) that contains the DOM. For example, Labor Day for 2006 was September 4. September 4 (1st Monday in September) is considered in the 1st WOM (even though there were 2 days of September in the previous week).</li> <li>■ When the current date matches the floating holiday (Month, DOW and WOM) or fixed holiday (Month, DOM and Year), the day plan assigned to the Exception Day plan replaces day plan selected by the Time Base Schedule.</li> </ul>	<p>1-5 = WOM</p> <p>1970-2105 = Year</p> <p>0 (zero) makes annual</p>
DAY PLAN	<p><b>Exception Day Plan</b></p> <p><b>1-16:</b> Selects Day Plan for this Exception Day.</p> <p><b>0 (zero):</b> Disables the Exception Day.</p>	<p>1-16</p> <p>0 disables</p>



## Detectors

### Detector Submenu, MM-6

DETECTOR SUBMENU
1. VEH DET PHASE ASSIGNMENT
2. VEHICLE DETECTOR SETUP
3. PED DETECTOR INPUT ASSIGNMENT
4. LOG INT / SPEED DETECTOR SETUP
5. VEHICLE DETECTOR DIAGNOSTICS
6. PEDESTRIAN DETECTOR DIAGNOSTICS

### Programming Summary

A brief description follows of the programming functions that can be viewed and/or changed at each of the menu options.

MM-6 Menu Option	Programming Summary
1. VEHICLE DETECTOR PHASE ASSIGNMENT	Accesses a data entry screen (MM-6-1) with which you can view or edit Detector Setup for all detectors (1-64). This menu enables NTCIP and ECPI Phase assignments.
2. VEHICLE DETECTOR SETUP	Accesses a data entry screen (MM-6-2) with which you can specify Vehicle Detector Type and TS2 Detector Select for all detectors (1-64).  <b>Assign</b> one of the detector types for each of the 64 detectors.  <b>Select</b> TS1 detectors installed in the detector rack.  <b>Select:</b> <ul style="list-style-type: none"> <li>■ TS 2 detector</li> <li>■ ECPI log</li> </ul>

▪ Programming Summary

MM-6 Menu Option	Programming Summary
3. PED DETECTOR INPUT ASSIGNMENT	Accesses a data entry screen (MM-6-3) with which you can assign Pedestrian Detectors to phases.
4. LOG INT/SPEED DETECTOR SETUP	<p>Accesses a data entry screen (MM-6-4) with which you can set NTCIP and ECPI log periods and set six different parameters related to speed detection:</p> <ul style="list-style-type: none"> <li>■ <b>Enter interval times</b> for NTCIP and ECPI detector logging.</li> <li>■ <b>Assign local detectors</b> to up to 16 speed detectors.</li> <li>■ <b>Select</b> one or two detector speed calculations.</li> <li>■ <b>Specify length</b> for Vehicle and Trap length.</li> <li>■ <b>Enable logging</b> of vehicle speeds.</li> <li>■ <b>Specify</b> English or Metric units.</li> </ul>
5. VEHICLE DETECTOR DIAGNOSTICS	<p>Accesses a data entry screen (MM-6-5) to view and edit the four Vehicle Detector Diagnostic Plans.</p> <p><b>Enter:</b></p> <ul style="list-style-type: none"> <li>■ Erratic count limit.</li> <li>■ No activity time</li> <li>■ Maximum presence time</li> <li>■ Multiplier for no-activity and max-presence time</li> <li>■ Fail extension</li> <li>■ Fail delay</li> </ul>
6. PEDESTRIAN DETECTOR DIAGNOSTICS	<p>Accesses a data entry screen (MM-6-6) to view and edit the four Pedestrian Detector Diagnostic Plans.</p> <p><b>Enter:</b></p> <ul style="list-style-type: none"> <li>■ Erratic count limit</li> <li>■ No activity time</li> <li>■ Maximum presence time</li> <li>■ Multiplier for no-activity and max-presence time</li> </ul>

## Vehicle Detector Phase Assignment, MM-6-1

```

VEH DET PH ASSIGN VEH DET PLAN [ 1] > v
[   ADDITIONAL PHASE CALLS   ]
DET PH 1 2 3 4 5 6 7 8 9 0 1 2 3 4 5 6 T
 1   1 . . . . . . . . . . . . . . . . . S
 2   2 . . . . . . . . . . . . . . . . . S
 3   3 . . . . . . . . . . . . . . . . . S
 4   4 . . . . . . . . . . . . . . . . . S
 5   5 . . . . . . . . . . . . . . . . . S
 6   6 . . . . . . . . . . . . . . . . . S
 7   7 . . . . . . . . . . . . . . . . . S
 8   8 . . . . . . . . . . . . . . . . . S
 9   9 . . . . . . . . . . . . . . . . . S
10  10 . . . . . . . . . . . . . . . . . S
11  11 . . . . . . . . . . . . . . . . . S
12  12 . . . . . . . . . . . . . . . . . S
13  13 . . . . . . . . . . . . . . . . . S
14  14 . . . . . . . . . . . . . . . . . S
15  15 . . . . . . . . . . . . . . . . . S
16  16 . . . . . . . . . . . . . . . . . S
//
64   0 . . . . . . . . . . . . . . . . . S
    
```

Scroll through this screen to view, inhibit (NTCIP) or assign Vehicle phases to Detectors for all detectors (1 thru 64). You can also assign Vehicle phases to Detectors in MM-6-2.

MM-6-1 Parameter	Description	Range
VEHICLE DET PH ASSIGN VEH DET PLAN	<b>Vehicle Detector Plan Number</b>  1 NTCIP 1202 2.3.2 2-4 ECPI (Econolite) Feature  Select the detector plan (1-4) to view or edit.	1 - 4
PH	<b>Assigned Phase</b>  NTCIP 1202 2.3.2.3  Select enable (1-16) or inhibit (0) the phase to which this detector is assigned.  0 (zero): Inhibits the detector from calling or extending any phase. This is used when the detector is an NTCIP system detector logging or ECPI system (MM-6-4) detector exclusively.  1-16: Enables the detector to call and extend that phase depending on programming.	0 - 16

**Detectors**

- *Vehicle Detector Phase Assignment, MM-6-1*

MM-6-1 Parameter	Description	Range
1 thru 16	<p><b>Phases Called By This Detector</b></p> <p>This is an ECPI Feature.</p> <p>TOGGLE to enable (X) or disable (.) this detector to call and extend phases in addition to the assigned phase.</p> <p><b>Note • This is displayed as READ-ONLY in status screen.</b></p> <p>Entries for each of 64 detectors:</p> <p>NEMA TS1 or TS2 Type controller detectors:</p> <ul style="list-style-type: none"> <li>1-8 are available on the A, B, C connectors.</li> <li>9-16 are available on the D connector.</li> <li>17 – 24 are available on the optional 25-pin telemetry module.</li> </ul> <p>NEMA TS2 Type 1 and 2 controller detectors:</p> <ul style="list-style-type: none"> <li>1-16 are available through DET BIU 1.</li> <li>17-32 are available through DET BIU 2.</li> <li>33-48 are available through DET BIU 3.</li> <li>49-64 are available through DET BIU 4.</li> </ul>	X, “.”

MM-6-1 Parameter	Description	Range
T Column	<p><b>Detector Type</b></p> <p><b>1</b> Move cursor to the T column.</p> <p>The full name of the selected detector type comes into view next to its letter abbreviation.</p> <p><b>2</b> Toggle to select detector type.</p> <p>Below are the available types. For detailed descriptions of each detector type, refer to <i>Vehicle Detector Setup, MM-6-2</i> on page 11-6.</p> <p><b>S-STANDARD (with EXTEND/DELAY)</b></p> <p>Type S, was <i>ASC/2</i> Type 1</p> <p><b>D-DISCONNECT TYPE QUEUE/STOP BAR</b></p> <p>Type D, was <i>ASC/2</i> Type 4</p> <p><b>P-PASSAGE TYPE QUEUE/STOP BAR</b></p> <p>Type P, was <i>ASC/3</i> Type 2, <i>ASC/2</i> Type 3 or 5</p> <p><b>C-CALLING</b></p> <p>Type C, was <i>ASC/2</i> Type 6</p> <p><b>R-RED EXTENSION</b></p> <p>Type R, was <i>ASC/3</i> Type 3</p> <p><b>G-GREEN EXTENSION/DELAY</b></p> <p>Type G, was <i>ASC/3</i> Type 1, <i>ASC/2</i> Type 2</p> <p><b>N-NTCIP</b></p> <p>Type N, was <i>ASC/3</i> Type 0</p> <p><b>B-BIKE</b></p> <p>Type B, was <i>ASC/2</i> Type 7</p>	S, D, P, C, R, G, N, B

- *Vehicle Detector Setup, MM-6-2*

## Vehicle Detector Setup, MM-6-2

Use this menu to select the correct detector type and the associated parameters for your needs. Except for Type G, Type P, and Type R, all detectors types are NTCIP 1202 compliant. The un-related NTCIP parameters for each NTCIP 1202 compliant detector type are hidden to reduce programming complexity. NTCIP detector type is retained for backward visual compatibility. For your convenience, you can also assign Vehicle phases (PH) to Detectors (DET) here in MM-6-2 as well as in MM-6-1.

Detector Type	Available Options
<p><b>S-STANDARD DETECTION with EXTEND/DELAY</b></p> <p>Type S, was <i>ASC/2</i> Type 1</p> <p>The detector output will call for the phase(s) and RESETS the phase green EXT TIME (MM-2-1).</p> <p>EXTEND TIME, if used: When there is a gap in the input to this detector this feature extends the output call to the phase(s) by the time that is programmed on the EXTEND TIME.</p>	<pre> VEH DETECTOR [ 1]   VEH DET PLAN [ 1] TYPE: S-STANDARD TS2 DETECTOR..... X ECPI LOG..... NO DET PH - 1 2 3 4 5 6 7 8 9 0 1 2 3 4 5 6 1 1 . . . . . EXTEND TIME... 0.0 DELAY TIME... 0.0 USE ADDED INITIAL . CROSS SWITCH PH.. 0 LOCK IN..... NONE NTCIP VOL . OR OCC . PMT QUEUE DELAY. NO                     </pre> <p>DELAY TIME, if used: Delays the call to the phase (when in yellow or red) until the delay timer times out. Then the detector will call the phase. If the detector call drops and another call is placed, the delay feature will start again.</p>
<p><b>D-DISCONNECT QUEUE/STOP BAR</b></p> <p>Type D, was <i>ASC/2</i> TYPE 4:</p> <p>This is a Stop Bar disconnect detector.</p> <p>The reasons this detector will disconnect are:</p> <ul style="list-style-type: none"> <li>■ There is a GAP to the detector input.</li> <li>■ The detector DISCONNECT TIME times out.</li> </ul>	<pre> VEH DETECTOR [ 1]   VEH DET PLAN [ 1] TYPE: D-DISCONNECT TYPE QUEUE/STOP BAR TS2 DETECTOR..... X ECPI LOG..... NO DET PH - 1 2 3 4 5 6 7 8 9 0 1 2 3 4 5 6 1 1 . . . . . DISCONNECT TIME..... 0 USE ADDED INITIAL . CROSS SWITCH PH.. 0 LOCK IN..... NONE NTCIP VOL . OR OCC . PMT QUEUE DELAY. NO                     </pre> <p><b>Note</b> • The DISCONNECT TIME should be greater than ZERO.</p> <p><b>Note</b> • For this detector to operate, there must be a call on this detector's input before the phase goes green.</p>

Detector Type	Available Options
<p><b>P-PASSAGE QUEUE/STOP BAR</b></p> <p>Type P, was <i>ASC/3</i> Type 2, <i>ASC/2</i> Type 3/5:</p> <p>This is a Stop Bar disconnect detector.</p> <p>This detector will disconnect when there is a gap in the detector input that is greater than the <i>PASSAGE</i> timer.</p>	<pre> VEH DETECTOR [ 1]   VEH DET PLAN [ 1] TYPE: P-PASSAGE TYPE QUEUE/STOP BAR TS2 DETECTOR..... X ECPI LOG..... NO DET PH - 1 2 3 4 5 6 7 8 9 0 1 2 3 4 5 6 1 1 . . . . . PASSAGE TIME..... 0.0 USE ADDED INITIAL . CROSS SWITCH PH.. 0 LOCK IN..... NONE NTCIP VOL . OR OCC . PMT QUEUE DELAY. NO                     </pre> <p><b>Note</b> • For this detector to operate, there must be a call on this detector input before the phase goes green.</p>
<p><b>C-CALLING DETECTOR</b></p> <p>Type C, was <i>ASC/2</i> Type 6:</p> <p>Places a call on the phase(s) only when the phase is NOT Green.</p>	<pre> VEH DETECTOR [ 1]   VEH DET PLAN [ 1] TYPE: C-CALLING TS2 DETECTOR..... X ECPI LOG..... NO DET PH - 1 2 3 4 5 6 7 8 9 0 1 2 3 4 5 6 1 1 . . . . . USE ADDED INITIAL . CROSS SWITCH PH.. 0 LOCK IN..... NONE NTCIP VOL . OR OCC . PMT QUEUE DELAY. NO                     </pre>
<p><b>R-RED EXTENSION</b></p> <p>Type R, was <i>ASC/3</i> Type 3:</p> <p>When you enable this feature, the phase RED CLEAR interval can be EXTENDED to time up to the RED MAX interval programmed in MM-2-1.</p>	<pre> VEH DETECTOR [ 1]   VEH DET PLAN [ 1] TYPE: R-RED EXTENSION TS2 DETECTOR..... X ECPI LOG..... NO DET PH - 1 2 3 4 5 6 7 8 9 0 1 2 3 4 5 6 1 1 . . . . .                     </pre>
<p><b>G-GREEN EXTENSION/DELAY</b></p> <p>Type G, was <i>ASC/3</i> Type 1, <i>ASC/2</i> Type 2:</p> <p>Using this detector type enables the delay timer and extension timer to function during the green time of all assigned phases.</p> <p>The detector extension timer works normally. The first call received when the phase goes green, whether present when green starts or received later, is recognized immediately. Calls received before the extension time gaps out will reset the EXTENSION TIME timer. When the extension timer times out, all further calls are delayed by the DELAY TIMER.</p>	<pre> VEH DETECTOR [ 1]   VEH DET PLAN [ 1] TYPE: G-GREEN EXTENSION/DELAY TS2 DETECTOR..... X ECPI LOG..... NO DET PH - 1 2 3 4 5 6 7 8 9 0 1 2 3 4 5 6 1 1 . . . . . EXTEND TIME... 0.0 DELAY TIME... 0.0 USE ADDED INITIAL . CROSS SWITCH PH.. 0 LOCK IN..... NONE NTCIP VOL . OR OCC . PMT QUEUE DELAY. NO                     </pre> <p>The delay timer of this detector does not function during the NOT GREEN time of the assigned phase(s).</p> <p>Delay only works if the assigned phase is green and the extension time is set to zero.</p>

**Detectors**

- *Vehicle Detector Setup, MM-6-2*

Detector Type	Available Options
<p><b>N-NTCIP</b></p> <p>Type N, was <i>ASC/3</i> Type 0: NTCIP defined detector.</p> <p>Supports all NTCIP functionality.</p> <p><b>Note • Passage/Queue and Yellow/Red locks have been combined for ease of programming.</b></p>	<pre> VEH DETECTOR [ 1]   VEH DET PLAN [ 1] TYPE: N-NTCIP TS2 DETECTOR..... X ECPI LOG..... NO DET PH - 1 2 3 4 5 6 7 8 9 0 1 2 3 4 5 6 1 1 . . . . . CALL OPTION.... YES DELAY TIME... 0.0 EXT OPTION. PASSAGE EXTENSION TIME. 0.0 USE ADDED INITIAL . CROSS SWITCH PH.. 0 LOCK IN..... NONE NTCIP VOL . OR OCC . PMT QUEUE DELAY. NO                     </pre>
<p><b>B-BIKE</b></p> <p>Type B, was <i>ASC/2</i> Type 7:</p> <p>Operates like the standard detector but enables the bike minimum green interval when the phase is served. Bike minimum green times concurrently with phase minimum green. During phase green the detector operates in extend mode and phase green is extended by the detector extend time.</p>	<pre> VEH DETECTOR [ 1]   VEH DET PLAN [ 1] TYPE: B-BIKE TS2 DETECTOR..... X ECPI LOG..... NO DET PH - 1 2 3 4 5 6 7 8 9 0 1 2 3 4 5 6 1 1 . . . . . EXTEND TIME... 0.0 NTCIP VOL . OR OCC .                     </pre>

Use this display to view or edit all of the parameters listed for four Vehicle Plans. It is repeated for plans 2-4 and detectors 2-64.

Detectors are identified by numbers 1 through 64. These are assigned various functions, times, and phases. Detectors must be defined at this data entry page to use for phases and/or logging.

**To assign vehicle detectors 1-64 to any of the 16 system detector phases:**

- 1** Select the vehicle plan number (VEH DET PLAN).
- 2** Select the detector number (VEH DETECTOR).
- 3** Assign the type of detector (TYPE).
- 4** Enter other options as necessary.



MM-6-2 Parameter	Description	Range
VEH DETECTOR	<p><b>Vehicle Detector Number</b></p> <p>Use the numeric (0-9) keys to specify the detector (1-64) to view or edit or specify 0 (zero) to select the next non-programmed detector.</p> <p><b>1-64:</b> Selects the detector to view or edit.</p>	1-64
VEH DET PLAN	<p><b>Vehicle Detector Plan Number</b></p> <p>Use the numeric keys to specify the detector plan (1-4) to view or edit.</p> <p><b>1</b> = NTCIP 1202 2.3.2</p> <p><b>2-4</b> = Econolite feature</p>	1-4
TYPE	<p><b>Detector Type</b></p> <p>Refer to detailed Detector Type descriptions in the previous table in <i>Vehicle Detector Setup, MM-6-2</i> on page 11-6.</p>	S, D, P, C, R, G, B, N
TS2 DETECTOR	<p><b>NEMA TS2 Rack Detector Enable</b></p> <p>Allows a NEMA TS1 detector to be installed in the TS2 detector rack without failing because of a failed detector processor. The TS1 rack detector did not have this signal.</p> <p>“.”: The installed detector is not a TS2 detector. The enabled detector and its companion output will not be forced TRUE when a detector process monitor failure is reported. This allows the use of non-NEMA TS2 detectors, such as TS1 detector, in the NEMA TS2 detector rack.</p> <p><b>X:</b> The installed detector is a TS2 detector. This and its companion output must comply with the NEMA TS2 specification.</p> <p><b>Note • Detectors are companions (occupy the same detector rack slot) if they are odd-even pair (for example, 5-6 are companions).</b></p> <p>Non-NEMA TS2 detectors do NOT supply Processor Monitor, Shorted Loop, Open Loop or Excessive Inductance change information.</p>	X enables “.” disables

## Detectors

- *Vehicle Detector Setup, MM-6-2*

MM-6-2 Parameter	Description	Range
ECPI LOG	<p><b>Log of Detector Activity</b></p> <p><b>YES:</b> Enables the local logging of this detector's volume and occupancy activity.</p> <p><b>NO:</b> Disables.</p> <p><b>Note</b> • The period of the log is ECPI LOG PERIOD (MM-6-4) and DET LOG (MM-5-2) in the Action Plan in effect.</p>	<p>YES enable</p> <p>NO disable</p>
<p>EXTEND TIME</p> <p><b>Or</b></p> <p>PASSAGE TIME</p> <p><b>Or</b></p> <p>EXTENSION TIME</p>	<p><b>Detector Extend/Passage Time</b></p> <p>Use the numeric (0-9) keys to specify the extend time (0.0 to 25.5 seconds) that a passage detector extends the assigned phase after termination of the input.</p> <p><b>Note</b> • The assigned phase may also be extended additionally by the phase extension time (MM-2-1).</p>	0.0 – 25.5 sec
DELAY TIME	<p><b>Detector Delay Time</b></p> <p>Use the numeric (0-9) keys to define the time (0.0 – 255.0 seconds) that the raw detector input is ignored or delayed when the assigned or called phase(s) is not green.</p> <p><b>Note</b> • The controller does not skip a phase that has an active but delayed detector. A delayed detector (that has a delay time in this field) is serviced when DUAL ENTRY (MM-2-6-1) is enabled.</p>	0.0 – 255.0 seconds
USE ADDED INITIAL	<p><b>Use Added Initial</b></p> <p>Toggle to enable (YES) or disable (NO) this detector to accumulate counts used in the added initial calculation by the assigned or called phase(s). Counts are accumulated for a phase from the beginning of the yellow interval, through red, the beginning of the next green interval.</p> <p><b>Note</b> • The phase uses the most active detector unless the Added Initial Calculation by Phase option (AI CALC MM-2-8) is enabled for the phase. It allows this detection to extend a concurrent timing phase.</p>	<p>YES enable</p> <p>NO disable</p>

MM-6-2 Parameter	Description	Range
CROSS SWITCH PH	<p><b>Vehicle Detector Switch Phase</b></p> <p>Use the numeric (0-9) keys to enable (1-16) or disable (0) switching of this detector output.</p> <p><b>1-16:</b> Switches the detector call and vehicle extension time to this phase when the assigned phase is not green and the switch phase is green.</p> <p><b>Note • When you assign cross switching to a detector, the cross switching is functional for multiple phases assigned to that detector.</b></p> <p><b>0 (zero):</b> Disables any switching of the detector output.</p> <p><b>Note • This is suggested for a permissive movement that is allowed to extend with calls from a concurrent phase. The cross-switched Gap Time will never override a greater active vehicle extension timer. If the switch phase reaches a Gap Out state, it can no longer be extended and you should use Simultaneous Gap (MM-1-1-4) programming.</b></p> <p>When there is a phase switch, the extension timer is included with the call. The timer used for the gap time will always be the greater of the active vehicle extension time and the gap time.</p>	<p>1-16 enable</p> <p>0 disable</p>
LOCK IN	<p><b>Lock Detector During Phase Yellow or Red</b></p> <p><b>NONE:</b> Disables—no lock on the detector.</p> <p><b>RED:</b> Start locking detector on RED when not timing.</p> <p><b>Note • When set to RED, this sets a “Red Smart Lock” state in which the detector only locks on RED after the phase stops timing. The red clear interval is <i>not</i> included so an unnecessary call will <i>not</i> remain for a left turn vehicle that is in the intersection during a red clear.</b></p> <p><b>YELLOW:</b> Start locking detector on YELLOW.</p>	<p>NONE</p> <p>RED</p> <p>YELLOW</p>
NTCIP VOL	<p><b>NTCIP Volume Detector</b></p> <p>Toggle to enable (YES) or disable (NO) this detector.</p> <p><b>YES:</b> Enables this detector to accumulate volume counts according to NTCIP.</p> <p><b>Note • This is the volume count over the NTCIP LOG PERIOD (MM-6-4).</b></p>	<p>YES enable</p> <p>NO disable</p>

## Detectors

- *Vehicle Detector Setup, MM-6-2*

MM-6-2 Parameter	Description	Range
NTCIP OCC	<p><b>NTCIP Occupancy Detector</b></p> <p>Toggle to enable (YES) or disable (NO) this detector.</p> <p><b>YES:</b> Enables this detector to accumulate occupancy data according to NTCIP.</p> <p><b>Note</b> • The occupancy count is in .05% counts over the NTCIP LOG PERIOD (MM-6-4).</p>	<p>YES enable</p> <p>NO disable</p>
PMT QUEUE DELAY	<p><b>Preempt Queue Delay Detector Select</b></p> <p>When selected, this detector is used to calculate the wait time of its assigned phase since last demand and the number of actuations (cars waiting) of that phase.</p> <p><b>Note</b> • To use wait times and cars waiting values in preempt, you must set PMT QUEUE DELAY to YES here in MM-6-2 and also set QUEUE DELAY to YES in MM-4-1.</p>	<p>YES enable</p> <p>NO disable</p>
DISCONNECT TIME	<p><b>Disconnect or Queue Detector Limit Time</b></p> <p>Use the numeric (0-9) keys to define the time (0 – 255 seconds) after the phase becomes green that “Q” detection can continue to extend the assigned green phase.</p> <p><b>Note</b> • “Q” detector operation allows the extension of the green interval on the assigned phase until the input is removed or the phase has been green for a period equal to the Queue Limit time, whichever occurs first. Phase green may be shorter due to other overriding parameters (i.e., Maximum time, Force Offs, etc.). Once disconnected, the assigned phase must terminate green to reset the “Q” detector operation.</p>	<p>0 – 255 seconds</p>

MM-6-2 Parameter	Description	Range
CALL OPTION	<p><b>Detector Phase Call Option</b></p> <p>Toggle to enable (YES) or disable (NO) this detector to call the assigned phase when it is not green.</p> <p><b>YES:</b> Enables detector to place a call to the assigned and called phase(s) while they are not green.</p> <p><b>NO:</b> Disables the detector from calling.</p>	<p>YES enable</p> <p>NO disable</p>
EXT OPTION	<p><b>Extension Mode Options</b></p> <p>This parameter is the combination of the 2 NTCIP parameters QUEUE option and PASSAGE option.</p> <p><b>PASSAGE:</b> extend the assigned phase during green up to the EXTENSION TIME (parameter to the right—range 0-25.5 sec.).</p> <p><b>QUEUE: “Q”</b> detector operation allows the extension of the green interval on the assigned phase until the input is removed or the phase has been green for a period equal to the QUEUE LIMIT time (parameter to the right— range 0-255 sec.), whichever occurs first. Once disconnected, the assigned phase must terminate green to reset the “Q” detector operation.</p>	<p>NONE, PASSAGE, QUEUE</p>

- Pedestrian and System Detector Options, MM-6-3

## Pedestrian and System Detector Options, MM-6-3

You can select from two modes of operation, as shown below:

MM-6-3 Parameter	Description	Range
MODE	<p><b>NTCIP:</b> Use this mode to assign multiple phases to a single detector.</p> <p><b>ECONOLITE:</b> This mode gives you more flexibility because you can use it to assign multiple phases to multiple detectors.</p> <p>The data assignment is not interchangeable between these 2 modes.</p> <p>When you select a new mode, it is necessary for the system to go through Transaction Mode before it enables the new mode.</p>	NTCIP, ECONOLITE

### NTCIP Mode with MM-6-3

PED DET PHASE ASSIGNMENT MODE: NTCIP								
PHASE	1	2	3	4	5	6	7	8
DETECTOR	1	2	3	.	.	.	5	.
PHASE	9	10	11	12	13	14	15	16
DETECTOR	10	.	.	.	.	.	.	.

Assign pedestrian detectors 1-16 to any of the 16 phases.

MM-6-3 Parameter	Description	Range
DETECTOR	<p><b>Phase For Pedestrian Detector</b></p> <p><b>1-16:</b> Move the cursor under a phase number (PHASE #), 1-16, and then enter the pedestrian detector input number (1-16) for that phase.</p> <p><b>0 (zero):</b> Disables any pedestrian detector input to that phase.</p> <p><b>Note</b> • The same pedestrian detector can be assigned to multiple phases.</p>	1-16 0 disables

Econolite Mode with MM-6-3

PED DET	PHASE	ASSIGNMENT	MODE:ECONOLITEV
PHASE	1	2	3 4 5 6 7 8 9 0 1 2 3 4 5 6
D	1	X	. . . . .
E	2	.	X . . . . .
T	3	.	. . . . .
E	4	.	. . . . B . . . . .
C	5	.	. . . . .
T	6	.	. . . . . 2 . . . . .
O	7	.	. . . . .
R	8	.	. . . . .
	9	.	. . . . .
	10	.	. . . . . X . . . . .
	11	.	. . . . .
	12	.	. . . . .
	13	.	. . . . .
	14	.	. . . . .
	15	.	. . . . .
	16	.	. . . . .

Assign pedestrian detectors 1-16 to any of the 16 phases.

MM-6-3 Parameter	Description	Range
DETECTOR	<p><b>Phase For Pedestrian Detector</b></p> <p>Toggle to enable/disable the pedestrian detector to call the assigned phase(s).</p> <p>“.” = No assignment, disabled</p> <p><b>X</b> = Assigns Pedestrian Push Button (PPB) to call the phase or phases</p> <p><b>2</b> = Call for Ped timing 2</p> <p><b>B</b> = Allows for the PPB to call for Min Green 2 (BIKE GREEN)</p>	<p>“.”</p> <p>X</p> <p>2</p> <p>B</p>

- Log Interval - Speed Detector Setup, MM-6-4

## Log Interval - Speed Detector Setup, MM-6-4

```

LOG - SPEED DETECTOR SETUP
NTCIP LOG.  0 ECPI LOG.  TBAP LENGTH. INCH
      SPEED DET  1  2  3  4  5  6  7  8
LOCAL DET.....  0  0  0  0  0  0  0  0
ONE/TWO DET.....  1  1  1  1  1  1  1  1
VEH LENGTH.....  0  0  0  0  0  0  0  0
TRAP LENGTH.....  0  0  0  0  0  0  0  0
ENABLE LOG.....  .  .  .  .  .  .  .  .

      SPEED DET  9 10 11 12 13 14 15 16
LOCAL DET.....  0  0  0  0  0  0  0  0
ONE/TWO DET.....  1  1  1  1  1  1  1  1
VEH LENGTH.....  0  0  0  0  0  0  0  0
TRAP LENGTH.....  0  0  0  0  0  0  0  0
ENABLE LOG.....  .  .  .  .  .  .  .  .
    
```

Use this display to view or edit the NTCIP and ECPI Log Period settings and, with horizontal scrolling, view or edit the settings for five different parameters on 16 Speed Detectors.

MM-6-4 Parameter	Description	Range
NTCIP LOG PERIOD	<p><b>Period for Logging of NTCIP Detectors</b></p> <p>Use the numeric (0-9) keys to select the number of seconds in each period of volume and occupancy data collection.</p> <p><b>Note • Observe the programming notes below:</b></p> <ul style="list-style-type: none"> <li>▪ Changing this entry resets the data collection period and deletes any accumulated data.</li> <li>▪ Only NTCIP Volume or Occupancy enabled detectors (MM-6-2) will be logged.</li> <li>▪ Only the last complete sample is maintained in memory.</li> </ul>	0-255 seconds



MM-6-4 Parameter	Description	Range
ECPI LOG PERIOD	<p><b>Period for Logging of ECPI Log Detectors</b></p> <p>Toggle to select the number of minutes (5, 15, 30, or 60) for local logging of detector data or select TBAP to allow the Time Base Action Plan (TBAP) to select the log interval.</p> <p><b>Note • Observe the programming notes below:</b></p> <ul style="list-style-type: none"> <li>■ Changing of this entry will take place when the present log interval is complete.</li> <li>■ Only ECPI LOG enabled detectors (MM-6-2) will have volume and occupancy logged.</li> <li>■ Only enabled speed detectors will have their speed logged.</li> <li>■ The logs are maintained until the log buffer is full. When full, the log buffer deletes the oldest entry to make space for the newest.</li> </ul>	TBAP = Time Base Action Plan or 5, 15, 30, 60 minutes
LENGTH	<p>Selects units of inches or centimeters for all parameters related to distance. This affects the calculations display and logging of speed.</p> <p>Toggle to select INCH or CM (centimeter), as appropriate.</p> <p><b>Note • Inches calculates speed in miles per hour. Centimeters calculates speed in kilometers per hour.</b></p>	INCH, CM
SPEED DETECTOR NUMBER	Sixteen (1-16) detectors can be used for vehicle speed.	1-16
LOCAL DET	<p><b>Speed Detector Local Detector Number</b></p> <p>Position the cursor beneath the number (0-16) of the Speed Detector to be edited, then use the numeric (0-9) keys to enter the number (1-64) of the Vehicle Detector to be assigned or enter 0 to disable that Speed Detector.</p> <p><b>Note • Observe the programming notes listed below:</b></p> <ul style="list-style-type: none"> <li>■ Detectors assigned to a phase may be used as a speed detector.</li> <li>■ One-detector speed calculation can use even or odd-numbered detectors.</li> <li>■ Two-detector speed calculation requires an odd-numbered detector to be assigned. The next even-numbered detector is the second detector for the speed calculations.</li> </ul>	1-64 0 = not active

## Detectors

- *Log Interval - Speed Detector Setup, MM-6-4*

MM-6-4 Parameter	Description	Range
ONE/TWO DET	<p>Use Toggle, <b>0/YES</b>, to enable one (1) or two (2) speed calculations for Speed Detectors 1-16.</p> <p><b>1: One-detector Speed.</b> The detector encountering a passing vehicle starts a counter by an actuation and stops the counter when it is deactivated. Speed is calculated using the vehicle travel time over the detection zone and the vehicle length.</p> <p><b>2: Two-detector speed calculation.</b> The first detector encountered by a passing vehicle is the Start Detector and the second is the End Detector. A travel time counter is started by an actuation of the Start Detector and stopped by an actuation of the End Detector. Speed is calculated using the vehicle travel time and distance between detectors.</p> <p><b>Note • Observe the programming notes below:</b></p> <ul style="list-style-type: none"> <li>■ The LENGTH UNIT entry INCH calculates speed in miles per hour. CM (centimeter) calculates speed in kilometers per hour.</li> <li>■ Speed that reads back to the arterial master is used to generate a log of speed readings in low, nominal, and high speed bands.</li> </ul>	1 or 2
VEH LENGTH	<p><b>Average Vehicle Length</b></p> <p><b>0-999:</b> Enter the average vehicle length in centimeters or inches encountered in the traffic lane for one-detector speed calculations.</p> <p><b>Note • This length is used in conjunction with the effective length of the detection zone (TRAP LENGTH) and the time that the detector is occupied to determine the one-detector speed.</b></p>	0-999 in. 0-999 cm.
TRAP LENGTH	<p><b>0-999:</b> The effective Trap Length distance.</p> <p>For one-detector speed trap calculation, it is the effective detection distance from start edge to stop edge of detection.</p> <p>For two-detector speed trap calculation it is the effective detection distance between two detectors from start edge to start edge of detection.</p> <p><b>Note • The effective detection zone will differ from physical length due to a variety of electrical and magnetic factors. Enter the length that produces the most representative speeds.</b></p>	0-999 in. 0-999 cm.
ENABLE LOG	<p><b>Enable Speed Trap Log</b></p> <p><b>X:</b> Enables local logging of speed data.</p> <p><b>“.” :</b> Disables logging.</p>	X enables “.” disables

## Vehicle Detector Diagnostics, MM-6-5

VEH	DIAG	PLAN	NUMBER [ 1 ]	FAILED			V
DET	COUNT	ACT	PRES	X'S	TIME	CL	DELAY
1	255	255	255	60	255		0
2	0	0	0	1	255		0
3	0	0	0	1	255		0
4	0	0	0	1	255		0
5	0	0	0	1	255		0
6	0	0	0	1	255		0
7	0	0	0	1	255		0
8	0	0	0	1	255		0
9	0	0	0	1	255		0
10	0	0	0	1	255		0
11	0	0	0	1	255		0
12	0	0	0	1	255		0
13	0	0	0	1	255		0
//							
64	0	0	0	1	255		0

Screen above is repeated for plans 2-4.

### For this screen:

- 1 Enter Vehicle Diagnostic Plan Number to be viewed or edited.
- 2 For each of 64 detectors (DET column) enter desired diagnostic parameters in the COUNT, ACT, PRES, X'S, FAILED TIME and FAILED CL DELAY columns.

**Note** • The Detector Diagnostic Plans are enabled by the Time Base Action Plan.

MM-6-5 Parameter	Description	Range
VEH DIAG PLAN NUMBER	Use the numeric (0-9) keys to enter the number (1-4) of the Vehicle Diagnostics Plan that you wish to view or edit.	1-4
DET column	<b>Vehicle Detector Number</b> Go to the desired detector number by using the cursor or enter the desired detector number (1-64) and press <b>ENTER</b> .	1-64
COUNT column	<b>Vehicle Erratic Counts</b> <b>1-255:</b> Specifies the vehicle detector Counts Per Minute (CPM) that, when exceeded, logs a failed vehicle detector if logging is enabled. <b>0 (zero):</b> Disables this diagnostic calculation for that vehicle detector.	1-255 CPM 0 disables

## Detectors

- *Vehicle Detector Diagnostics, MM-6-5*

MM-6-5 Parameter	Description	Range
ACT column	<p><b>Vehicle No-Activity</b></p> <p><b>1-255 minutes:</b> Time interval between vehicle detections that, when exceeded, logs a failed vehicle detector if logging is enabled.</p> <p><b>0 (zero):</b> Disables the No Activity diagnostic.</p>	1-255 min.
PRES column	<p><b>Vehicle Maximum Presence</b></p> <p><b>1-255 minutes:</b> Time for continuous vehicle detection that when exceeded, logs a failed vehicle detector if logging is enabled.</p> <p><b>0 (zero):</b> Disables Maximum Presence diagnostic.</p>	0-255 min.
X'S column	<p><b>Multiplier (Scaling Factor)</b></p> <p>Determines length of the No-Activity and Maximum Presence periods.</p> <p><b>1, 2, 15, 60:</b> No-Activity and Maximum Presence periods that have values between 1 and 255 minutes will be multiplied by these values resulting in desired period length.</p> <p><b>Examples:</b></p> <p>No Activity period = 60 min, Multiplier = 2. Result: No Activity is reported if detector is inactive for (60 x 2) or 120 minutes.</p> <p>Maximum Presence period = 50 sec, Multiplier = 15. Result: Max presence failure is reported if detector is active for (50 x 15) or 750 minutes.</p>	1, 2, 10, 15, 60

MM-6-5 Parameter	Description	Range
FAILED TIME column	<p><b>Failed Detector Extend Time</b></p> <p>Use the numeric (0-9) keys to specify the time (0-255 seconds) the failed detector can extend the assigned phase.</p> <p><b>1-254:</b> Allows the failed detector to call and extend the assigned phase for the programmed time.</p> <p><b>255:</b> Places a max recall on the phase.</p> <p><b>0 (zero):</b> Disables the failed detector from calling or extending the assigned phase.</p> <p><b>Note</b> • NTCIP 1202 2.3.2.12 Bits 0-3 defines an NTCIP failed detector. Bit 7 defines a detector that failed the internal detector diagnostics (MM-7-6).</p>	0-255 seconds
FAILED CL DELAY column	<p><b>Failed Detector Delay Time</b></p> <p>Use the numeric (0-9) keys to specify the time (0-255 seconds) that a failed detector will be delayed.</p> <p><b>1-255:</b> Defines the time that a failed detector will not put a call on the assigned phase after it terminated green.</p> <p><b>0 (zero):</b> Disables the delay.</p>	0-255 seconds

## Pedestrian Detector Diagnostics, MM-6-6

PED DETECTOR DIAG PLAN[1]				
DET	COUNTS	ACT	PRES	MULTIPLIER
1	0	0	0	1
2	0	0	0	1
3	0	0	0	1
4	0	0	0	1
5	0	0	0	1
6	0	0	0	1
7	0	0	0	1
8	0	0	0	1
9	0	0	0	1
10	0	0	0	1
11	0	0	0	1
12	0	0	0	1
13	0	0	0	1
14	0	0	0	1
15	0	0	0	1
16	0	0	0	1

Screen above is repeated for plans 2-4.

## Detectors

- *Pedestrian Detector Diagnostics, MM-6-6*

### For this screen:

- 1 Enter the Pedestrian Diagnostic Plan Number (1-4) to view or edit.
- 2 For each of 16 detectors (DET column) enter desired diagnostic parameters in the Counts, Act, Pres, and Multiplier columns.

---

**Note** • The Detector Diagnostic Plans are enabled by the Time Base Action Plan.

---

MM-6-6 Parameter	Description	Range
PED DETECTOR DIAGNOSTIC PLAN NUMBER	Use the numeric (0-9) keys to enter the number (1-4) of the Pedestrian Diagnostic Plan that you wish to view or edit.	1-4
DET column	<b>Pedestrian Detector Number</b> Go to the desired detector number by using the cursor or enter the desired detector number (1-16) and press the ENTER key.	1-16
COUNTS column	<b>Pedestrian Erratic Counts</b> <b>1-255:</b> Specifies the pedestrian detector Counts Per Minute (CPM) that, when exceeded, logs a failed pedestrian detector if log is enabled. <b>0 (zero):</b> Disables this diagnostic calculation for the pedestrian detector.	0-255 CPM
ACT column	<b>Pedestrian No-Activity</b> <b>1-255 minutes:</b> Time interval between pedestrian detections that, when exceeded, logs a failed pedestrian detector if logging is enabled. <b>0 (zero):</b> Disables the No Activity diagnostic.	0-255 min.

MM-6-6 Parameter	Description	Range
PRES column	<p><b>Pedestrian Maximum Presence</b></p> <p><b>1-255 minutes:</b> Time for continuous pedestrian detection, that when exceeded, logs a failed pedestrian detector if logging is enabled.</p> <p><b>0 (zero):</b> Disables Maximum Presence diagnostic.</p>	0-255 min.
MULTIPLIER column	<p><b>Multiplier (Scaling Factor)</b></p> <p>Determines the length of the No-Activity and Maximum Presence periods.</p> <p><b>1, 2, 10, 15, 60:</b> No-Activity and Maximum Presence periods that have values between 1 and 255 minutes are multiplied by these values resulting in period length.</p> <p><b>Examples:</b></p> <ul style="list-style-type: none"> <li>■ No Activity period = 60 min, Multiplier = 2. Result: No Activity is reported if detector is inactive for (60 x 2) or 120 minutes.</li> <li>■ Maximum Presence period = 50 min, Multiplier = 15. Result: Max presence failure is reported if detector is active for (50 x 15) or 750 minutes.</li> </ul>	1, 2, 10, 15, and 60

---

**For your notes:**



## Status Displays

### Introduction

The *ASC/3* Main Status Display (to access, press **STATUS DISPLAY**), is designed to show an overall status at a glance, with more detailed status screens available for each function. The layout of each status display is carefully designed to fit the compact display area and also give as much information as possible. The status displays are designed as 16-line displays. For *2070*, press **NEXT** to toggle the status display to see the full view.

The displays are grouped into one Main Status Display and eight functional categories, listed below in the order they are given in this chapter.

Status Display	Navigation
The Main Status Display, a summary of important status information. The full display for this is 16-lines.	Press <b>STATUS DISPLAY</b> (for <i>2070</i> , press <b>E</b> )
Controller	MM-7-1
Coordinator	MM-7-2
Preemption/Transit Signal Priority (TSP)	MM-7-3
Time Base: Time of Day (TBC)/Action Plan	MM-7-4
Communications	MM-7-5
Detectors	MM-7-6
Flash/ Synchronous Data Link Control (SDLC)/ Malfunction Management Unit (MMU)	MM-7-7
Inputs/Outputs	MM-7-8

### ▪ Main Status Displays

In all the status displays, there are a number of procedures with which you can get more information or make calls. These procedures are listed below:

#### **From a black hyperlink field, to go the related data entry screen:**

- ▶ For *ASC/3*, press **SPEC FUNC** then **NEXT DATA**.  
To return to this display, press **SUB MENU**.
- ▶ For *2070*, press **\*** then **D**. To return to this display, press **ESC**.

#### **To get context-sensitive Help for a status field:**

- ▶ Move the cursor to that field, and press **HELP** (for *2070*, press **F**).

#### **To make a Call on a Display Row:**

- 1** Use number keys to make a call on Vehicle, Pedestrian, or Preemptor.
- 2** Move the cursor to the related display row and press a related key(s), **0** thru **9**, to enter a number from 1 thru 10. This is an *internal* call. If the cursor is in the first row of the status display, pressing a numeric key causes a call on the corresponding Vehicle phase.

#### **To make a Call on a Cursor Field (Vehicle, Pedestrian, Preemptor, or TSP):**

- 1** Move the cursor to the related field.
- 2** Press **ENTER**. This is an *internal* call.

#### **To hear a beeper sound when there is a data change:**

- 1** Move the cursor to the status field.
- 2** When a change occurs in the field, you hear a beep.

## Main Status Displays

There are two Main Status Displays—Basic and Advanced. These are shown below, followed by definitions of their entries.

#### **To select the type of Main Status Display for the default:**

- 1** Go to MM-1-7-2.
- 2** Cursor to MAIN STATUS DISPLAY MODE.
- 3** Toggle to BASIC or ADVANCED.

#### **To view the Main Status Display:**

- 1** Press **STATUS DISPLAY** (for *2070*, press **E**).
- 2** From the Main Status Display, to toggle between the Advanced and Basic Main Status Display, press **NEXT SCREEN** (for *2070*, press **NEXT**).



## Status Displays

### ▪ Main Status Displays

Parameter	Definition	Parameter	Definition
[FAULT - PMT / LCK]	Preempt, Interlock fail for 3 possible causes: <ul style="list-style-type: none"> <li>• Preemptor and Interlock inputs both are ACTIVE simultaneously, even after Input Delay Time.</li> <li>• Interlock input is TRUE before 1 second was up.</li> <li>• Both Preemptor and Interlock inputs are INACTIVE simultaneously.</li> </ul>	[FAULT - PMT / CRC]	Preempt DB CRC not matched (MM-1-7-1). Need to change DB or rewire hardware CRC inputs.
[FLSH - LOCAL FL]	Local Flash detected [FLSH-ST MMU] MMU detected error. Stop time applied with Flash. Check MMU for error information.	[FLSH - ST MMU]	MMU detected error. Stop Time applied with Flash. Check MMU for error information.
[FLSH - CTR CVM]	Controller caused Flash. Verify that the database matches the controller type. For example, the 2070 A3000.db requires the 2070-2A module.	[FLSH - CTR TBC]	Flash by Time Base Control. Check active Action Plan.
[FLSH - CTR SYS]	Flash by Coord Pattern. Check active Coordination Pattern.	[FLSH MMU INPT]	MMU detects AUTO/FLASH input active.
[PMTxx DLY yyy]	Preemptor xx is timing down its Delay Timer yyy. When it reaches ZERO, the preempt will start.	[PMTxx INH yyy]	Preemptor xx is in its INHIBIT interval yyy. VEH/PED calls received during this interval will not be serviced until after the preemptor exits.
[PMTxx TCK yyy]	Track Clear Timing: Preemptor xx is timing its Track Clear Grn, Yel or Red.	[XXX DOWNLOAD]	Data is in the process of download.
[PMTxx DWL yyy]	Preemptor xx is timing down its Minimum Dwell time. Preempt may not exit until this timer reaches ZERO.	[XXX UPLOAD]	Data is in the process of upload.
[PMTxx FLSHyyy]	Preemptor xx is timing down its Minimum Dwell Flash time. Preempt cannot exit until this timer reaches ZERO.	[PMTxx EXT2CRD]	Preemptor xx is timing down its Minimum Dwell Time. Preempt cannot exit until this timer reaches ZERO.
[PMTxx EXT2PHS]	Pmt xx is attempting to exit to phases as directed by the coordinator.	[PMTxx EXTNONE]	Preemptor xx is exiting with no exit phases selected.
[MNL CT ENA IA]	Manual Control Enable, Interval Advance	[STOP TIME ]	Stop Time input is applied.
[xxx UPLOAD]	Port xxx is uploading.	[xxx DOWNLOAD]	Port xxx is downloading.

Parameter	Definition	Parameter	Definition
[CRD SYS Pyyy]	In Coordination, pattern yyy is active and is commanded by system software.	[CRD TBC Pyyy]	In Coordination, pattern yyy is active and is commanded by Time Base Control (TBC).
[CRD MAN Pyyy]	In coordination, manual pattern yyy is active.	[CRD FREE ALM]	In Coordination, incorrect parameter found in the commanding pattern.
[CRD yyFO ERR]	In Coordination, phase yy failed to be Forced-Off.	[CRD LZ ERR]	In Coordination, coordinated phase is not active at local zero.
[FREE MAN]	In free, manual free pattern is in effect.	[FREE INPUT]	In Free, commanded by hardware input.
[FREE SYS]	In Free, commanded by System source.	[FREE TBC]	In Free, commanded by Time Base Control (TBC).
[CRD TSPxSyyy]	In Coordination, TSP call x and split pattern yyy are active.	[FREE TSPxSyyy]	In Free, TSP call x and split pattern yyy are active.
[PMTxx GATEyyy]	Gate Down timer: Preemptor xx is timing down its Extend Track Green Timer yyy. <b>Note</b> • The timer will not start to time down until after the GATE DOWN input has occurred.	[FREE-DEFAULT ]	Free by Default
[ADAPTIVE-SYS]	Adaptive Mode	[ADAPTIVE P%3d]	Adaptive Pnnn
[FAULT-HRI/SO ]	Railway Non Operational	[FAULT-HRI/RX ]	No Railway Communication
[FAULT-HRI/GDN]	Preemptor Gate Down Err	[FAULT-CC_PUP ]	Consistency error detected at power up
[FLT-HRI/RHBA ]	Railway Equipment is not receiving CU transmissions.	[FLSH- ST CFM]	Flash Stop Time Conflict Monitor
[FLSH CROS-PMT]	Flash crossing number not assigned to preempt.	[FLSH RR NOPMT]	Flash RR preempt not enable
[FLSH RRLWPMT]	Flash RR preemptor is not set to high priority.	[PENDING ADAPT]	Pending Adaptive Pattern
[DET BIU ERROR]	DET BIU 1-8 Problem		

### Other Entries on Main Status Display, Line 1

- Current Controller *Date* in MM/DD/YY format
- Current Controller *Time* in HH:MM:SS format

- Main Status Displays

**Phase Status, in Order of Precedence, Main Status Display, Line 3**

PH STAT	Definition
—	Phase is NOT enabled
N	Phase in Next
R	Phase is Red
Y	Phase is timing Yellow
y (lower case y) special	Protected Permitted Left Turn (PPLT) — Flashing Yellow
D	Phase is timing delay green
G	Phase is Green
.	Phase is Red and not timing
X	Exclusive Pedestrian
f	Flashing Green

**Vehicle Call Information, Main Status Display, Line 4**

VEH CALL	Definition
Blank	Phase not enabled
O	Phase Omitted
E	Red extension call
C	Active vehicle detector call
B	Bike call
N	Phase is non-actuated (CNA1, CNA2, Pre-timed)
F	Call placed by detector diagnostic (Failed Detector)
M	Max recall programmed for phase
R	Vehicle recall programmed for phase
X	Call placed by Max out
I	Call placed by internal application (Power Up, Preemptor, Keypad input)
L	Locked vehicle detector call

VEH CALL	Definition
S	Call placed by Soft recall or do not rest here
.	No phase demand

**Pedestrian Call Information, Main Status Display, Line 5**

PED CALL	Definition
Blank	Ped not enabled
O	Ped Omitted
C	Active Pedestrian Detector Call
2	Active Pedestrian 2 Detector Call
N	Pedestrian Phase is non-actuated (CNA1, CNA2, Pre-timed)
F	Call placed by detector diagnostic (Failed Detector)
R	Pedestrian Recall
I	Call placed by internal application (Power Up, Keypad input, Logic)
L	Locked pedestrian call on the phase
.	No Pedestrian demand

**Ring and Active Phase for the Ring, Main Status Display, Line 6**

If a Ring is NOT active, the phase is a “.”

Parameter	Definition	Ranges	
RX/PH YY	Ring Number/Active Phase	X = 1 thru 4	YY = 01 thru 16

For example, R1/PH 04 | R2/PH 08 | R3/PH . . | R4/PH . .

shows that Ring 1 has active phase 4 | Ring 2 has active phase 8 | Ring 3 is not active | Ring 4 is not active.

**Active Phase Timing and Intervals, Main Status Display, Line 7**

Up to two active timers or intervals are shown simultaneously for the related ring.

▪ Main Status Displays

**Note** • For a timer, the timer value is shown to its right.

Parameter	Definition
EXT1	Green vehicle extension
EXT2	Green vehicle extension 2
GAPr	Gap reduction is in effect
GRNp	Preemptor minimum green override
GRN HOLD	Phase in HOLD interval
GRN REST	Phase rests in absence of calls
GRN XFER	Phase awaits timeout of another phase
INACTIVE	Phase is inactive
MGRN1	Minimum Green
MGRN2	Bike minimum green
MGRa	Additional Initial Green
MGRNd	Delay green for early walk
MGRNc	Conditional Service minimum green
MGRNg	Guaranteed minimum green
PED ONLY	Phase is timing pedestrian timing only
RED-	Vehicle red clearance
RED REST	Red rest
REDg	Guaranteed red clearance
REDp	Preemptor red override
RED EXTEND	Phase is timing red extension
RED XFER	Phase is in red transfer
RRVT	Phase is next but its red revert is timing
YEL-	Vehicle yellow change



Parameter	Definition
YELg	Guaranteed yellow change
YELp	Preemptor yellow override

### Active Phase Maximum Timing Control and Reason for Phase Termination, Main Status Display, Line 8

When a phase is actively timing, the parameter for the phase maximum is shown.

When the phase is terminated, it shows the reason for the termination (during the clearance interval of the phase — usually during yellow/red clearance).

Parameter	Definition
FORCE OFF	Terminated by command or force-off signal
GAP OUT	Gap between vehicles exceeded gap-out limit in effect in volume density operation
GUAR PASS	Full vehicle extension timed after time out of reduced gap
MAN ADV	Terminated by manual advance
MAX1	Max 1 is timing
MAX2	Max 2 is timing
MAX3	Max 3 is timing
MAXD	Max Dynamic is timing
MAX OUT	Green ext time reached its maximum limit
MAX GAP	Minimum gap was in effect when gap-out occurred
PC-1	Ped Clear 1 is timing
PC-2	Ped Clear 2 is timing
PC-G	Guarantee Ped Clear is timing
PC-M	Ped Clear Max is timing
PC-P	Preemptor is timing Ped Clear
PREEMPT	Terminated by preemption
REDm	Vehicle red clearance maximum
SPLT	Coordinator or TSP/SCP split timing is being used for the phase MAX time

**Status Displays**

▪ *Main Status Displays*

Parameter	Definition
TSP	TSP Split is timing
WK-1	Walk 1 is timing
WK-G	Guarantee Walk is timing
WALK HOLD	The phase is in Walk Hold
WALK REST	The Phase is in Walk Rest
WK-2	Walk 2 is timing
WLFT	Pre Time Walk (FT) is timing
WL-P	Preemptor is timing walk
WK-M	Walk max is timing

**Current Controller Configuration, Main Status Display, Line 9**

Parameter	Definition	Range
PLAN SPLT:XXX	Plan Split Pattern Number	XXX = 001 thru 120
TP:XX	Timing Plan Number	XX = 01 thru 04
SEQ:XX	Sequence Page Number	XX = 01 thru 16
ACT:XXX	Action Plan Number	XXX = 001 thru 100
DP:X	Detector Plan Number	X = 1 thru 4

**Coordination-Specific Timing Information, Main Status Display, Line 10**

These are in four separate areas, as show below: Local Cycle Counter, System Cycle Counter, Interconnect Format Cross Reference, and Current Coordination Status.

Parameter	Definition	Ranges		
LC:XXX+/YYY	Local Cycle Counter	XXX = counter	+ = s for seconds or % for percent	YYY = actual cycle length programmed
SYS CYC:XXX+	System Cycle Counter (Master Clock)	XXX = counter	+ = s for seconds or % for percent	

Parameter	Definition	Ranges
<b>Interconnect Format Cross Reference</b>		
PLN XXX	Interconnect Format = PLN	XXX = Plan Number
TS2 XX-X	Interconnect Format = TS2	XX-X = Cycle / Split Combination
COS XXX	Interconnect Format = STD	XXX = Cycle / Offset / Split Combination
<b>Current Coordination Status</b>		
FREE	Free	N/A
SYNC	Sync Pulse	
PICKUP	In pickup mode	
COORD	Coordinated (in step)	
DWELL	Dwelling / transition	
ADDONLY	Add Only Transition	
DEDUCT	Subtracting in Smooth Transition	
ADDING	Adding in Smooth Transition	

**Preempt (PMT) & Transit Signal Priority (TSP) Input Status, Main Status Display, Line 12**

10 possible Preempts (1 thru 10) are on the left, and 6 possible TSPs (1 thru 6) are on the right.

Parameter	Definition
<b>PMT Status (left 1 thru 10)</b>	
-	Not programmed
R	Re-service period
I	Preemptor is Inhibited
D	Delay timer is running for that preempt
A	Preempt run is active
C	Call, but that preempt is not yet active
.	Preempt is programmed/enabled, but there is no activity on it

- Main Status Displays

Parameter	Definition
<b>TSP Input Status (right 1 thru 6)</b>	
X	TSP is not programmed correctly (omits on TSP phases, no TSP pattern, no TSP phases)
R	Re-service period
I	Inhibited
A	Call is being/about-to-be served
N	NTCIP Commanded
C	Call pending from inputs
.	Enabled and Idle

**Logic Processor Flag Status, Main Status Display, Line 13**

16 possible Logic Processor Flags, 1 thru 16

LP FLAG	Definition
A	Active
.	Inactive
-	Not used

**Example for lines 14 thru 16**

```

14 COMMUNICATIONS PORT STATUS|TLM ADD:      1
15 ETH RX TX|P2  RX TX|P3A RX TX|P3B RX TX
16 2- ID . 1- OK OK|3  ID . 0  -  -
    
```

The communications subsection of the Main Status Display provides an overview of the communications status of the CU with a remote system (e.g. ASC/2 master controller or *icons* or Centracs central system). The active address the controller is accepting commands from is indicated by the “TLM ADD” field. The transmit and receive status for each port is also monitored and can be used by an operator to diagnose and troubleshoot basic communications issues. Further information can be gathered from the respective port or protocol status screens if necessary. The following example describes how one would interpret the example Main Status Display subsection illustrated above.

In the example above, “TLM ADD” indicates that the controller is configured to accept messages addressed to controller “1”. Further inspection of the port priorities, reveals that PORT 2 is configured with the highest priority, therefore it can be inferred that PORT 2 is configured with address “1”. The reception and transmission status of PORT 2 is “OK”, which indicates that communications is active valid, where validity of messages are determined by the controller traffic application software and therefore provide the best indication of the controller’s communications status. If communications is intermittent or with a delay longer than 50 ms, the appropriate port status field will indicate such a condition by changing from an “OK” to a “.”. Further lack of communications beyond the ports drop-out timer will be indicated with an “ID”. This state is important to the communications of controller because only at this time will it consider the port to be non-active and allow other remote systems communication over ports of lower-priority to begin commanding the controller. Keep in mind, polling messages/status requests are always accepted and replied to, regardless of port priority settings.

### Highest Priority Telemetry Address (TLM ADD), Main Status Display, Line 14

The range is 0 thru 65535.

In the example above, this address is 0.

### Communication Port Status, Main Status Display, Lines 15 and 16

Lines 15 and 16 show the status of four communication ports. For each port, you see:

The *name* of the port and its *priority* — Receive (RX) *status* — Transmit (TX) *status*

### Status of the Communications Ports in the EXAMPLE above

Name of the Port		Priority	Receive RX Status*	Transmit TX Status*
Parameter	Full Name			
ETH	Ethernet port	2	ID	.
P2	Port 2	1	OK	OK
P3A	RS232, Port 3A	3	ID	.
P3B	FSK/RS232, Port 3B	0/Disabled	-	-

\* Refer to the table below for the meanings of the RX and TX status entries.

- Main Status Displays

**Communication Ports Status, Main Status Display, Lines 15 and 16**

Parameter	Definition
ETH	Ethernet port
<b>NEMA Ports</b>	
P2	Port 2 (terminal port)
P3A	Port 3A (RS232 port)
P3B	Port 3B (FSK/RS232 port)
<b>2070 Ports</b>	
C50	C50S (front port on 2070)
C21	C21S (Optional module, either FSK or RS232; one module includes C21 & C22)
C22	C22S
<b>Receive Status, RX</b>	
-	Port disabled
OK	Reception in progress and with valid message
.	Port NOT Receiving (port Drop Timer still running)
ID	Port IDle (Drop Time expired)
<b>Transmit Status, TX</b>	
-	Port disabled
OK	Transmission in Progress, and the message is valid
.	Port NOT Receiving (port Drop Timer still running)

## Status Display Submenu, MM-7

STATUS DISPLAY SUBMENU	
1. CONTROLLER	6. DETECTORS
2. COORDINATOR	7. FLASH/SDLC/MMU
3. PREEMPTION/TSP	8. INPUTS / OUTPUTS
4. TBC/ACTION PLAN	
5. COMMUNICATIONS	

Brief descriptions follow of the contents of the *ASC/3* Status Displays.

### Main Status Screen

Press **STATUS DISPLAY** to see these Status Display parameters:

MM-7 Menu Option	Controller Status Display
1. CONTROLLER	<ul style="list-style-type: none"> <li>■ Current controller status including coordination source and pattern in effect or preemption status</li> <li>■ Current date and time</li> <li>■ Current phase status including Red, Yellow, Red and Phase Next for active phases</li> <li>■ Current overlap status including Red, Yellow, and Red for active phases</li> <li>■ Current pedestrian status including Walk, Pedestrian Clearance and Don't Walk</li> <li>■ Current vehicle and pedestrian demand for active phases</li> <li>■ Current split plan, timing plan, sequence, action plan and detector plan</li> <li>■ Current phase and interval currently timing and time remaining by ring</li> <li>■ Current density and maximum timers</li> <li>■ Current overlap signal timing and time remaining</li> <li>■ Current logic processor flag status</li> </ul>

## Status Displays

- *Status Display Submenu, MM-7*

MM-7 Menu Option	Controller Status Display
2. COORDINATOR	<ul style="list-style-type: none"><li>■ Current coordination status including coordination source and pattern in effect or preemption status.</li><li>■ Current date and time</li><li>■ Current phase status including Red, Yellow, Red and Phase Next for active phases</li><li>■ Current vehicle and pedestrian demand for active phases</li><li>■ Current vehicle and pedestrian permissive</li><li>■ Current phase and interval currently timing and time remaining by ring</li><li>■ Current split plan, timing plan, sequence, action plan and detector plan</li><li>■ Current local cycle timing and value, system cycle timing, COS received and coordination status</li><li>■ Indicates the next plan and the time of change</li><li>■ Indicated the split demand pattern and number of cycles remaining</li><li>■ Indicates per ring, hold, force off, split count down, split extension and the ring offset.</li></ul>



MM-7 Menu Option	Controller Status Display
<p>3. PREEMPTION/TSP</p>	<p><b>From MM-7-3-1 you can see these Preemptor Status Display parameters:</b></p> <ul style="list-style-type: none"> <li>■ Current controller status including coordination source and pattern in effect or preemption status.</li> <li>■ Current date and time</li> <li>■ Current phase status including Red, Yellow, Red and Phase Next for active phases</li> <li>■ Current pedestrian overlap status including Walk, Pedestrian Clearance and Don't Walk</li> <li>■ Current vehicle and pedestrian demand for active phases</li> <li>■ Current local cycle timing and value, system cycle timing, COS received and coordination status</li> <li>■ Current preempt timing by ring</li> <li>■ Current phase and interval currently timing and time remaining by ring</li> <li>■ Current preempt and TSP input status</li> <li>■ Current logic processor flag status</li> </ul> <p><b>From MM-7-3-2 you can see these TSP Status Display parameters:</b></p> <ul style="list-style-type: none"> <li>■ Current controller status including coordination source and pattern in effect or preemption status.</li> <li>■ Current date and time</li> <li>■ Current phase status including Red, Yellow, Red and Phase Next for active phases</li> <li>■ Current vehicle and pedestrian demand for active phases</li> <li>■ TSP or SCP plan in effect and status</li> <li>■ Current split plan, timing plan, sequence, action plan and detector plan</li> <li>■ Current local cycle timing and value, system cycle timing, COS received and coordination status</li> <li>■ Current phase and interval currently timing and time remaining by ring</li> <li>■ Current preempt and TSP input status</li> <li>■ Current logic processor flag status</li> </ul>

- Status Display Submenu, MM-7

MM-7 Menu Option	Controller Status Display
4. TBC/ACTION PLAN	<p><b>Note • TBC = Time Base Control</b></p> <p>From MM-7-4 you can see these Time Base Status Display parameters:</p> <ul style="list-style-type: none"> <li>■ Current date and time</li> <li>■ Command source</li> <li>■ The day plan that will be in effect next</li> <li>■ Indicates program step number in effect</li> <li>■ Indicates current day plan event start time and action plan number</li> <li>■ Indicates next twenty nine events, start time and action plan number</li> </ul>
5. COMMUNICATIONS	<ul style="list-style-type: none"> <li>■ Ethernet, MM-7-5-1</li> <li>■ Port 2/C50S, MM-7-5-2</li> <li>■ Port 3A/C21S, MM-7-5-3</li> <li>■ Port 3B/C22S, MM-7-5-4</li> <li>■ NTCIP, MM-7-5-5</li> <li>■ ECPIP, MM-7-5-6</li> <li>■ IEEE 1570, MM-7-5-7 (for details, refer to the <i>ASC/3 IEEE 1570 User Guide</i>, P/N 100-0903-008)</li> </ul>
6. DETECTORS	<ul style="list-style-type: none"> <li>■ Current date and time</li> <li>■ Detector selected, detector timing, delay and extend values</li> <li>■ Controller detector diagnostics</li> <li>■ TS-2 Detector diagnostics</li> <li>■ Detector status: <ul style="list-style-type: none"> <li>F: Failed diagnostics</li> <li>D: Delay is timing</li> <li>E: Extend is timing</li> <li>C: Active with no delay or extend</li> <li>S: Speed detector(s)</li> <li>“.”: No activity</li> <li>“-”: Not programmed, assigned or enabled</li> </ul> </li> </ul>

MM-7 Menu Option	Controller Status Display
<p>7. FLASH/SDLC/MMU</p>	<p>From MM-7-7 you can see the Flash/MMU Status Display parameters. This display shows the cause of a cabinet Flash condition. The various MM-7-7-1 Flash displays are:</p> <ul style="list-style-type: none"> <li>■ If there is no flash, it shows a NO FLASH CONDITION indicator</li> <li>■ Emergency Flash Conditions</li> <li>■ Both Emergency and MMU Flash Conditions</li> <li>■ Controller Flash Conditions including Automatic Flash Conditions</li> </ul> <p>From MM-7-7-2 you can see the Port 1 status messages from the BIUs and the MMU</p> <p>From MM-7-7-3 you can see the MMU compatibility programming in the controller and the MMU.</p>
<p>8. INPUTS / OUTPUTS</p>	<p>From MM-7-8 you can see the real time status of the inputs and outputs. The inputs and outputs can be viewed as:</p> <ul style="list-style-type: none"> <li>■ Functions – menu selections 1 &amp; 2</li> <li>■ Hardware – menu selections 3 &amp; 4</li> <li>■ Aux hardware – D and Telemetry – menu selection 5</li> <li>■ BIUs – selections 6 &amp; 7</li> <li>■ Logic Processor– menu selection 8</li> <li>■ I/O Differences– menu selection 9</li> </ul>

- Controller Status Display, MM-7-1

## Controller Status Display, MM-7-1

```

1 CONTROL[CORD SYS P120] MM/DD/YY|HH:MM:SS
2 PHASE 1 2 3 4 5 6 7 8 9 0 1 2 3 4 5 6
3 PH STAT . G R R G R R R - - - - -
4 VEH OVL R G R - - - - -
5 PED STAT - D - C - D - D - - - - -
6 VEH CALL . I I . . . . .
7 PED CALL . . . . .
8 PLAN SPLT: 12|TP: 4|SEQ: 1|ACT: 100|DP: 4
9 R1/PH 04|R2/PH 08|R3/PH ..|R4/PH ..
10 MGR1 0.0|YEL 0.0|INACTIVE |INACTIVE
11 PDCL 12.0|FORCE OFF| |
12 DEN00/000|DEN00/000|DEN00/000|DEN00/000
13 MAX 00.0|MAX 00.0|MAX 00.0|MAX 00.0
14 OLA G . |OLB Y 2.9|OLC R . |OLD R .
15 FUNCTION 1 2 3 4 5 6 7 8 9 0 1 2 3 4 5 6
16 LP FLAG . A . . . A . . . . .
    
```

When in a **hyperlink** field:

To follow the hyperlink:

For ASC/3, press **SPEC FUNC**, then **NEXT DATA**.

For 2070, press **B**.

To go back:

For ASC/3, press **SUB MENU**.

For 2070, press **ESC**.

### Active Plan or State – Controller Status, MM-7-1, Line 1

For this information (same as in the Main Status Display), refer to the table *Active Plan or State—Controller Status (MM-7-1, MM-7-2, MM-7-3-1/2), Line 1* on page 12-3.

### Other Entries on Controller Status, Line 1

Current Controller *Date* in MM/DD/YY format

Current Controller *Time* in HH:MM:SS format

### Phase Status, in Order of Precedence – Controller Status, MM-7-1, Line 3

PH STAT	Definition
–	Phase is NOT enabled
N	Phase in Next
R	Phase is timing Red
Y	Phase is timing Yellow
y (lower case y) special	Protected Permitted Left Turn (PPLT) yellow
D	Phase is timing delay green
.	Phase is Red and not timing
G	Phase is Green

PH STAT	Definition
X	Simultaneous Red/Yellow (orange)
F# (special)	Canadian FF (future native feature) F1, F2, F3

#### Vehicle Overlaps – Controller Status, MM-7-1, Line 4

VEH OVL	Definition
=	Overlap is not programmed (omitted)
A	Overlap is timing Advance green
N	Overlap is next
Y	Overlap is timing Yellow
y (special)	Protected Permitted Left Turn (PPLT)
G	Overlap is green
F#	Flashing Green Overlap
L	Overlap is Timing Lagging green
R	Overlap is Red

#### Pedestrian Overlap Status (order of precedence) – Controller Status, MM-7-1, Line 5

PED OVL	Definition
-	PED is not enabled
N	PED is next
W	PED is timing/in WALK
C	PED is timing PED CLEAR
O	PED is Omitted
D	PED is in DON'T WALK

- Controller Status Display, MM-7-1

**Vehicle Call Information – Controller Status, MM-7-1, Line 6**

VEH CALL	Definition
O	Phase Omitted
E	Red extension call
C	Active vehicle detector call
B	Bike call
I	Call placed by internal application (Power Up, Preemptor, Keypad input)
N	Phase is non-actuated (CNA1, CNA2, Pre-timed)
F	Call placed by detector diagnostic (Failed Detector)
M	Max recall programmed for phase
R	Vehicle recall programmed for phase
X	Call placed by Max out
L	Locked vehicle detector call
S	Call placed by Soft recall or do not rest here
.	No phase demand

**To make a Vehicle Call:**

- 1 Go to MM-7-1, Line 6, VEH CALL.
- 2 Obey the applicable procedure, below.

To Make a Vehicle Call on:	Procedure
All Phases	<ol style="list-style-type: none"> <li>1 Move the cursor to the second L of VEH CALL</li> <li>2 Press <b>ENTER</b>.</li> </ol>
One Phase (range 1 thru 16)	<ol style="list-style-type: none"> <li>1 Move the cursor to the applicable phase, 1 thru 16.</li> <li>2 Press <b>ENTER</b>.</li> </ol>
One Phase (range 1 thru 10)	<ol style="list-style-type: none"> <li>1 Move the cursor to anywhere in the VEH CALL line.</li> <li>2 Press the applicable number key <b>1</b> thru <b>0</b>.</li> </ol>

**Note** • You can use the same procedure, above, to make a Vehicle Call from any status display that has the VEH CALL parameter.

**Pedestrian Call Information – Controller Status, MM-7-1, Line 7**

PED CALL	Definition
O	Ped Omitted
C	Active Pedestrian Detector Call
2	Active Pedestrian 2 Detector Call
I	Call placed by internal application (Power Up, Keypad input, Logic)
N	Pedestrian Phase is non-actuated (CNA1, CNA2, Pre-timed)
F	Call placed by detector diagnostic (Failed Detector)
R	Pedestrian Recall
L	Locked pedestrian call on the phase
.	No Pedestrian demand

**To make a Pedestrian Call:**

- 1** Go to MM-7-1, Line 7, PED CALL.
- 2** Obey the applicable procedure, below.

To Make a Pedestrian Call on:	Procedure
All Phases	<ol style="list-style-type: none"> <li><b>1</b> Move the cursor to the second L of PED CALL</li> <li><b>2</b> Press <b>ENTER</b>.</li> </ol>
One Phase (range 1 thru 16)	<ol style="list-style-type: none"> <li><b>1</b> Move the cursor to the applicable phase, 1 thru 16.</li> <li><b>2</b> Press <b>ENTER</b>.</li> </ol>
One Phase (range 1 thru 10)	<ol style="list-style-type: none"> <li><b>1</b> Move the cursor to anywhere in the PED CALL line.</li> <li><b>2</b> Press the applicable number key <b>1</b> thru <b>0</b>.</li> </ol>

**Note** • You can use the same procedure, above, to make a Pedestrian Call from any status display that has the PED CALL parameter.

- Controller Status Display, MM-7-1

**Current Controller Configuration – Controller Status, MM-7-1, Line 8**

**Hyperlink Fields**

Parameter	Definition	Range
PLAN SPLT:XXX	Plan Split Pattern Number	XXX = 001 thru 120
TP:XX	Timing Plan Number	XX = 01 thru 04
SEQ:XX	Sequence Page Number	XX = 01 thru 16
ACT:XXX	Action Plan Number	XXX = 001 thru 100
DP:X	Detector Plan Number	X = 1 thru 4

**Ring and Active Phase for the Ring – Controller Status, MM-7-1, Line 9**

If a Ring is *not* active, the phase is a “.”

Parameter	Definition	Ranges	
RX/PH YY	Ring Number/Active Phase	X = 1 thru 4	YY = 1 thru 16

For example, R1/PH 4 | R2/PH 8 | R3/PH . | R4/PH .

shows that Ring 1 has active phase 4 | Ring 2 has active phase 8 | Ring 3 is not active | Ring 4 is not active

**Active Phase Timing and Intervals – Controller Status, MM-7-1, Lines 10 and 11**

Up to two active timers or intervals are shown simultaneously for the related ring.

**Note** • For a timer, the timer value is shown to its right.

Parameter	Definition
EXT1	Green vehicle extension
EXT2	Green vehicle extension 2
GAPr	Gap reduction is in effect
GRNp	Preemptor minimum green override
GRN HOLD	Phase in HOLD interval



Parameter	Definition
GRN REST	Phase rests in absence of calls
GRN XFER	Phase awaits timeout of another phase
INACTIVE	Ring is inactive
MGRN1	Minimum Green
MGRN2	Bike minimum green
MGRa	Additional Initial Green
MGRNd	Delay green for early walk
MGRNc	Conditional Service minimum green
MGRNg	Guaranteed minimum green
PED ONLY	Phase is timing pedestrian timing only
RED-	Vehicle red clearance
RED REST	Red rest
REDg	Guaranteed red clearance
REDp	Preemptor red override
RED EXTEND	Phase is timing red extension
RED XFER	Phase is in red transfer
RRVT	Phase is next but its red revert is timing
YEL-	Vehicle yellow change
YELg	Guaranteed yellow change
YELp	Preemptor yellow override

### Car/Time before Reduction – Controller Status, MM-7-1, Line 12

This is the count-down timer for time before reduction for each ring for the active phase operating under volume density (DEN).

DEN00/000

00/ = Cars waiting

/000 = Time before Reduction

- Controller Status Display, MM-7-1

**Maximum Time in Effect – Controller Status, MM-7-1, Line 13**

Maximum Time in Effect (Max 1, 2, 3 or current Dynamic Max value)

**Overlay Display (A, B, C, D), Color and Timing – Controller Status, MM-7-1, Line 14**

For the general expression, OL? C##.# , the key:

OL = Overlap

? = A, B, C or D (the identifier of the overlay display)

C = G, Y, R (the color)

##.# = Overlap Timing

**Logic Processor Flag Status – Controller Status, MM-7-1, Line 16**

16 possible Logic Processor Flags, 1 thru 16

LP FLAG	Definition
A	Active
.	Inactive
-	Not used

**To make a Vehicle Call:**

- 1 Go to Line 6, VEH CALL.
- 2 Obey the applicable procedure, below.

To Make a Vehicle Call on:	Procedure
All Phases	<ol style="list-style-type: none"> <li>1 Move the cursor to the second L of VEH CALL</li> <li>2 Press ENTER.</li> </ol>
One Phase	<ol style="list-style-type: none"> <li>1 Move the cursor to the applicable phase, 1 thru 16.</li> <li>2 Press ENTER.</li> </ol>
One Phase, 1 thru 10	<ol style="list-style-type: none"> <li>1 Move the cursor to anywhere in Line 6, VEH CALL.</li> <li>2 Press the applicable number key 1 thru 0.</li> </ol>

## Coordinator Status Display, MM-7-2

<pre> 1 COORD [CORD SYS P120] MM/DD/YY HH:MM:SS 2 PHASE 1 2 3 4 5 6 7 8 9 0 1 2 3 4 5 6 3 PH STAT R G R R G R R R - - - - - 4 VEH CALL . I I . . . . . 5 PED CALL . . . . . 6 PERMISVE . P . . V P . . . . . 7 PLAN SPLT: 12 TP: 4 SEQ: 1 ACT:100 DP:4 8 LC:115s/120 SYS CYL:110s COS 111  COORD 9 LOCAL OFFSET... 0s ACTUAL OFFSET.. 0s 10 NEXT PLAN.....XXXX NEXT TIME...xx:xx:xx 11 SPLIT DEMAND..XXX/00 RING 1 2 3 4 12 HOLD APPLIED TO PHASE 2 6 . . 13 FORCE OFF RING . . . . 14 SPLIT TIMING 0s 0s 0s 0s 15 SPLIT EXTENSION TIME 0s 0s 0s 0s 16 RING OFFSETS 0s 0s 0s 0s                 </pre>	<p><b>When in a <span style="background-color: black; color: white;">hyperlink</span> field:</b></p> <p><b>To follow the hyperlink:</b></p> <p>For ASC/3, press <b>SPEC FUNC</b>, then <b>NEXT DATA</b>.</p> <p>For 2070, press <b>B</b>.</p> <p><b>To go back:</b></p> <p>For ASC/3, press <b>SUB MENU</b>.</p> <p>For 2070, press <b>ESC</b>.</p>
--	---

### Active Plan or State – Controller Status, MM-7-2, Line 1

For this information (same as in the Main Status Display), refer to the table *Active Plan or State—Controller Status (MM-7-1, MM-7-2, MM-7-3-1/2), Line 1* on page 12-3.

### Other Entries on Controller Status, Line 1

Current Controller *Date* in MM/DD/YY format

Current Controller *Time* in HH:MM:SS format

### Phase Status, in Order of Precedence – Coordinator Status, MM-7-2, Line 3

PH STAT	Definition
-	Phase is NOT enabled
N	Phase in Next
R	Phase is timing Red
Y	Phase is timing Yellow
y (lower case y) special	Protected Permitted Left Turn (PPLT) yellow
D	Phase is timing delay green
.	Phase is Red and not timing
G	Phase is Green

## Status Displays

- Coordinator Status Display, MM-7-2

PH STAT	Definition
X	Simultaneous Red/Yellow (orange)
F# (special)	Canadian FF (future native feature) F1, F2, F3

### Vehicle Call Information – Coordinator Status, MM-7-2, Line 4

VEH CALL	Definition
O	Phase Omitted
E	Red extension call
C	Active vehicle detector call
B	Bike call
I	Call placed by internal application (Power Up, Preemptor, Keypad input)
N	Phase is non-actuated (CNA1, CNA2, Pre-timed)
F	Call placed by detector diagnostic (Failed Detector)
M	Max recall programmed for phase
R	Vehicle recall programmed for phase
X	Call placed by Max out
L	Locked vehicle detector call
S	Call placed by Soft recall or do not rest here
.	No phase demand

**To make a Vehicle Call:**

- 1** Go to MM-7-2, Line 4, VEH CALL.
- 2** Obey the applicable procedure, below.

To Make a Vehicle Call on:	Procedure
All Phases	<ol style="list-style-type: none"> <li><b>1</b> Move the cursor to the second L of VEH CALL</li> <li><b>2</b> Press <b>ENTER</b>.</li> </ol>
One Phase (range 1 thru 16)	<ol style="list-style-type: none"> <li><b>1</b> Move the cursor to the applicable phase, 1 thru 16.</li> <li><b>2</b> Press <b>ENTER</b>.</li> </ol>
One Phase (range 1 thru 10)	<ol style="list-style-type: none"> <li><b>1</b> Move the cursor to anywhere in the VEH CALL line.</li> <li><b>2</b> Press the applicable number key <b>1</b> thru <b>0</b>.</li> </ol>

**Note** • You can use the same procedure, above, to make a Vehicle Call from any status display that has the VEH CALL parameter.

**Pedestrian Call Information – Coordinator Status, MM-7-2, Line 5**

PED CALL	Definition
0	Ped Omitted
C	Active Pedestrian Detector Call
2	Active Pedestrian 2 Detector Call
I	Call placed by internal application (Power Up, Keypad input, Logic)
N	Pedestrian Phase is non-actuated (CNA1, CNA2, Pre-timed)
F	Call placed by detector diagnostic (Failed Detector)
R	Pedestrian Recall
L	Locked pedestrian call on the phase
.	No Pedestrian demand

## Status Displays

- Coordinator Status Display, MM-7-2

### To make a Pedestrian Call:

- 1 Go to MM-7-2, Line 5, PED CALL.
- 2 Obey the applicable procedure, below.

To Make a Pedestrian Call on:	Procedure
All Phases	<ol style="list-style-type: none"> <li>1 Move the cursor to the second L of PED CALL</li> <li>2 Press <b>ENTER</b>.</li> </ol>
One Phase (range 1 thru 16)	<ol style="list-style-type: none"> <li>1 Move the cursor to the applicable phase, 1 thru 16.</li> <li>2 Press <b>ENTER</b>.</li> </ol>
One Phase (range 1 thru 10)	<ol style="list-style-type: none"> <li>1 Move the cursor to anywhere in the PED CALL line.</li> <li>2 Press the applicable number key <b>1</b> thru <b>0</b>.</li> </ol>

**Note** • You can use the same procedure, above, to make a Pedestrian Call from any status display that has the PED CALL parameter.

### Permissive Windows – Coordinator Status, MM-7-2, Line 6

PERMISVE	Definition
V	Vehicle Permissive window is open for this phase
P	Pedestrian Permissive window is open for this phase. Pedestrian permissive “P” overwrites Vehicle permissive “V” display.

### Current Controller Configuration – Coordinator Status, MM-7-2, Line 7

#### Hyperlink Fields

Parameter	Definition	Range
PLAN SPLT:XXX	Plan Split Pattern Number	XXX = 001 thru 120
TP:XX	Timing Plan Number	XX = 01 thru 04
SEQ:XX	Sequence Page Number	XX = 01 thru 16
ACT:XXX	Action Plan Number	XXX = 001 thru 100
DP:X	Detector Plan Number	X = 1 thru 4

### Coordination-Specific Timing Information, Coordinator Status, MM-7-2, Line 8

These are in four separate areas, as shown below: Local Cycle Counter, System Cycle Counter, Interconnect Format Cross Reference, and Current Coordination Status

Parameter	Definition	Ranges		
LC:XXX+/YYY	Local Cycle Counter	XXX = counter	+ = s for seconds or % for percent	YYY = actual cycle length programmed
SYS CYC:XXX+	System Cycle Counter (Master Clock)	XXX = counter	+ = s for seconds or % for percent	
<b>Interconnect Format Cross Reference</b>				
PLN XXX	Interconnect Format = PLN	XXX = Plan Number		
TS2 XX-X	Interconnect Format = TS2	XX-X = Cycle / Split Combination		
COS XXX	Interconnect Format = STD	XXX = Cycle / Offset / Split Combination		
<b>Current Coordination Status</b>				
FREE	Free	N/A		
SYNC	Sync Pulse			
PICKUP	In pickup mode			
COORD	Coordinated (in step)			
DWELL	Dwelling / Transition			
ADDONLY	Add Only Transition			
DEDUCT	Subtracting in Smooth Transition			
ADDING	Adding in Smooth Transition			

### Local Offset, Coordinator Status, MM-7-2, Line 9 (left side)

Parameter	Definition	Range
LOCAL OFFSET.....XXs	This is the programmed offset time of the running coordinated pattern.	Seconds or %, set in MM-3-1

- Coordinator Status Display, MM-7-2

**Actual Offset, Coordinator Status, MM-7-2, Line 9 (right side)**

Parameter	Definition	Range
ACTUAL OFFSET . . . . .XXs	This is the current offset time of the running coordinated pattern. In transition, this value is different from the local offset and will keep changing until it reaches the local offset value.	Seconds or %, set in MM-3-1

**Next Plan, Coordinator Status, MM-7-2, Line 10 (left side)**

Parameter	Definition	Range
NEXT PLAN . . . . .XXX	Next Plan Number	XXX = 1 thru 100

**Next Time, Coordinator Status, MM-7-2, Line 10 (right side)**

Parameter	Definition	Range
NEXT TIME . . . XX:XX:XX	Next Scheduled Plan Time	hh:mm:ss (time of day)

**Split Demand, Coordinator Status, MM-7-2, Line 11**

Parameter	Definition	Range
SPLIT DEMAND . . .XXX/YYY	XXX = Split Pattern Number YYY = Remaining number of cycles for the selected pattern	XXX = 001 thru 120 YYY = 01 thru 255

**Hold Applied to Phase, Coordinator Status, MM-7-2, Line 12**

Parameter	Definition	Range
HOLD APPLIED TO PHASE	Identifies which phases have a hold applied. The phase number is shown under the ring number in which it is currently timing.	Phases 1 thru 16



**Force-Off Ring, Coordinator Status, MM-7-2, Line 13**

Parameter	Definition	Range
FORCE OFF RING	Identifies which rings have a force-off applied to the phase timing.	X = Force-off on the ring . = No force-off on the ring

**Split Timing, Coordinator Status, MM-7-2, Line 14**

Parameter	Definition	Range
SPLIT TIMING	Shows the remaining available split time (in seconds) for each active phase in each ring. If a phase has “redirected split” time allocated to it from another phase, the SPLIT TIMING timer shall show the calculated split time.	0 thru 999

**Split Extension Time, Coordinator Status, MM-7-2, Line 15**

Parameter	Definition	Range
SPLIT EXTENSION TIME	Shows any split extension time (in seconds or percent of cycle, determined from coordination options) for actuated coordinated phases in each ring, if actuated coordination is used.	Cycle length -1 in seconds or 0 thru 99 in percent



### Phase Status, in Order of Precedence – Preemptor Status, MM-7-3-1, Line 3

PH STAT	Definition
–	Phase is NOT enabled
N	Phase in Next
R	Phase is timing Red
Y	Phase is timing Yellow
y (lower case y) special	Protected Permitted Left Turn (PPLT) yellow
D	Phase is timing delay green
.	Phase is Red and not timing
G	Phase is Green
X	Simultaneous Red/Yellow (orange)
F# (special)	Canadian FF (future native feature) F1, F2, F3

### Vehicle Overlaps – Preemptor Status, MM-7-3-1, Line 4

VEH OVL	Definition
–	Overlap is not programmed (omitted)
A	Overlap is timing Advance green
N	Overlap is next
Y	Overlap is timing Yellow
y (special)	Protected Permitted Left Turn (PPLT)
G	Overlap is green
F#	Flashing Green Overlap
L	Overlap is Timing Lagging green
R	Overlap is Red

- *Preemptor Status Display, MM-7-3-1*

**Pedestrian Status Overlap (order of precedence) – Preemptor Status, MM-7-3-1, Line 5**

PED OVL	Definition
–	PED is not enabled
N	PED is next
W	PED is timing/in WALK
C	PED is timing PED CLEAR
O	PED is Omitted
D	PED is in DON'T WALK

**Vehicle Call Information – Preemptor Status, MM-7-3-1, Line 6**

VEH CALL	Definition
O	Phase Omitted
E	Red extension call
C	Active vehicle detector call
B	Bike call
I	Call placed by internal application (Power Up, Preemptor, Keypad input)
N	Phase is non-actuated (CNA1, CNA2, Pre-timed)
F	Call placed by detector diagnostic (Failed Detector)
M	Max recall programmed for phase
R	Vehicle recall programmed for phase
X	Call placed by Max out
L	Locked vehicle detector call
S	Call placed by Soft recall or do not rest here
.	No phase demand

**To make a Vehicle Call:**

- 1** Go to MM-7-3-1, Line 6, VEH CALL.
- 2** Obey the applicable procedure, below.

To Make a Vehicle Call on:	Procedure
All Phases	<ol style="list-style-type: none"> <li><b>1</b> Move the cursor to the second L of VEH CALL</li> <li><b>2</b> Press <b>ENTER</b>.</li> </ol>
One Phase (range 1 thru 16)	<ol style="list-style-type: none"> <li><b>1</b> Move the cursor to the applicable phase, 1 thru 16.</li> <li><b>2</b> Press <b>ENTER</b>.</li> </ol>
One Phase (range 1 thru 10)	<ol style="list-style-type: none"> <li><b>1</b> Move the cursor to anywhere in the VEH CALL line.</li> <li><b>2</b> Press the applicable number key <b>1</b> thru <b>0</b>.</li> </ol>

**Note** • You can use the same procedure, above, to make a Vehicle Call from any status display that has the VEH CALL parameter.

**Pedestrian Call Information – Preemptor Status, MM-7-3-1, Line 7**

PED CALL	Definition
O	Ped Omitted
C	Active Pedestrian Detector Call
2	Active Pedestrian 2 Detector Call
I	Call placed by internal application (Power Up, Keypad input, Logic)
N	Pedestrian Phase is non-actuated (CNA1, CNA2, Pre-timed)
F	Call placed by detector diagnostic (Failed Detector)
R	Pedestrian Recall
L	Locked pedestrian call on the phase
.	No Pedestrian demand

- Preemptor Status Display, MM-7-3-1

**To make a Pedestrian Call:**

- 1 Go to MM-7-3-1, Line 7, PED CALL.
- 2 Obey the applicable procedure, below.

To Make a Pedestrian Call on:	Procedure
All Phases	<ol style="list-style-type: none"> <li>1 Move the cursor to the second L of PED CALL</li> <li>2 Press <b>ENTER</b>.</li> </ol>
One Phase (range 1 thru 16)	<ol style="list-style-type: none"> <li>1 Move the cursor to the applicable phase, 1 thru 16.</li> <li>2 Press <b>ENTER</b>.</li> </ol>
One Phase (range 1 thru 10)	<ol style="list-style-type: none"> <li>1 Move the cursor to anywhere in the PED CALL line.</li> <li>2 Press the applicable number key <b>1</b> thru <b>0</b>.</li> </ol>

**Note** • You can use the same procedure, above, to make a Pedestrian Call from any status display that has the PED CALL parameter.

**Coordination-Specific Timing Information, Preemptor Status, MM-7-3-1, Line 8**

These are in four separate areas, as show below: Local Cycle Counter, System Cycle Counter, Interconnect Format Cross Reference, and Current Coordination Status

Parameter	Definition	Ranges		
LC:XXX+/YYY	Local Cycle Counter	XXX = counter	+ = s for seconds or % for percent	YYY = actual cycle length programmed
SYS CYC:XXX+	System Cycle Counter (Master Clock)	XXX = counter	+ = s for seconds or % for percent	
<b>Interconnect Format Cross Reference</b>				
PLN XXX	Interconnect Format = PLN	XXX = Plan Number		
TS2 XX-X	Interconnect Format = TS2	XX-X = Cycle / Split Combination		
COS XXX	Interconnect Format = STD	XXX = Cycle / Offset / Split Combination		

Parameter	Definition	Ranges
<b>Current Coordination Status</b>		
FREE	Free	N/A
SYNC	Sync Pulse	
PICKUP	In pickup mode	
COORD	Coordinated (in step)	
DWELL	Dwelling / Transition	
ADDONLY	Add Only Transition	
DEDUCT	Subtracting in Smooth Transition	
ADDING	Adding in Smooth Transition	

### Ring and Active Phase for the Ring – Preemptor Status, MM-7-3-1, Line 9

If a Ring is *not* active, the phase is a “.”

Parameter	Definition	Ranges	
RX/PH YY	Ring Number/Active Phase	X = 1 thru 4	YY = 1 thru 16

For example, R1/PH 4 | R2/PH 8 | R3/PH . | R4/PH .

shows that Ring 1 has active phase 4 | Ring 2 has active phase 8 | Ring 3 is not active | Ring 4 is not active

### Preemptor Interval Status – Preemptor Status, MM-7-3-1, Line 10

Parameter	Definition
NOT PMT	Not in Preemption
PMT STRT	Preemptor going to Entrance phases
CLR TRK	Preemptor going to Track Clear phases and functions
DWL/CYCL	Preemptor is in the dwell cycle movement
EXITING	Preemptor Exit

- Preemptor Status Display, MM-7-3-1

**Active Phase Timing and Intervals – Preemptor Status, MM-7-3-1, Line 11**

Up to two active timers or intervals are shown simultaneously for the related ring.

**Note** • For a timer, the timer value is shown to its right.

Parameter	Definition
EXT1	Green vehicle extension
EXT2	Green vehicle extension 2
GAPr	Gap reduction is in effect
GRNp	Preemptor minimum green override
GRN HOLD	Phase in HOLD interval
GRN REST	Phase rests in absence of calls
GRN XFER	Phase awaits timeout of another phase
INACTIVE	Ring is inactive
MGRN1	Minimum Green
MGRN2	Bike minimum green
MGRa	Additional Initial Green
MGRNd	Delay green for early walk
MGRNc	Conditional Service minimum green
MGRNg	Guaranteed minimum green
PED ONLY	Phase is timing pedestrian timing only
RED-	Vehicle red clearance
RED REST	Red rest
REDg	Guaranteed red clearance
REDp	Preemptor red override
RED EXTEND	Phase is timing red extension
RED XFER	Phase is in red transfer
RRVT	Phase is next but its red revert is timing



Parameter	Definition
YEL-	Vehicle yellow change
YELg	Guaranteed yellow change
YELp	Preemptor yellow override

### Phase Termination Timing, Preemptor Status, MM-7-3-1, Line 12

When a phase is terminated (during yellow change and red clearance), the reason for the termination is shown here.

Parameter	Definition
FORCE OFF	Terminated by command or force-off signal
GAP OUT	Gap between vehicles exceeded gap-out limit in effect in volume density operation
GUAR PASS	Full vehicle extension timed after time out of reduced gap
MAN ADV	Terminated by manual advance
MAX1	Max 1 is timing
MAX2	Max 2 is timing
MAX3	Max 3 is timing
MAXD	Max Dynamic is timing
MAX OUT	Green ext time reached its maximum limit
MAX GAP	Minimum gap was in effect when gap-out occurred
PDCL	Ped Clearance
PC-1	Ped Clear 1 is timing
PC-2	Ped Clear 2 is timing
PC-G	Guarantee Ped Clear is timing
PC-M	Ped Clear Max is timing
PC-P	Preemptor is timing Ped Clear
PREEMPT	Terminated by preemption
REDm	Vehicle red clearance maximum

**Status Displays**

- *Preemptor Status Display, MM-7-3-1*

Parameter	Definition
SPLT	SPLT: Coordinator or TSP/SCP split timing is being used for the phase MAX time.
TSP	TSP Split is timing
WK-1	Walk 1 is timing
WK-G	Guarantee Walk is timing
WALK HOLD	The phase is in Walk Hold
WALK REST	The Phase is in Walk Rest
WK-2	Walk 2 is timing
WLFT	Pre Time Walk (FT) is timing
WL-P	Preemptor is timing walk
WK-M	Walk max is timing

**Preemptor (PMT) & Transit Signal Priority (TSP) Input Status  
Preemptor Status, MM-7-3-1, Line 15**

10 possible Preempts (1 thru 10) are on the left, and 6 possible TSPs (1 thru 6) are on the right

Parameter	Definition
<b>PMT Status (left 1 thru 10)</b>	
–	Not Programmed
R	Re-service period
I	Preemptor is Inhibited
D	Delay timer is running for that preempt
A	Preempt run is active
C	Call, but that preempt is not yet active
.	Preempt is programmed/enabled, but there is no activity on it

Parameter	Definition
<b>TSP Input Status (right 1 thru 6)</b>	
X	TSP is not programmed correctly (omits on TSP phases, no TSP pattern, no TSP phases)
R	Re-service period
I	Inhibited
A	Call is being served
N	NTCIP Commanded
C	Call from inputs
.	Enabled and Idle

### Logic Processor Flag Status, Preemptor Status, MM-7-3-1, Line 16

16 possible Logic Processor Flags, 1 thru 16

LP FLAG	Definition
A	Active
.	Inactive
—	Not used

- TSP/SCP Status Display, MM-7-3-2

## TSP/SCP Status Display, MM-7-3-2

For more information about Transit Signal Priority (TSP) and Signal Control and Prioritization (SCP), refer to the *TSP User Guide, ASC/3*, P/N 100-0903-003.

<pre> 1  TSP/SCP[FREE-TBC      ]02/12/08 07:09:40 2  PHASE 1 2 3 4 5 6 7 8 9 0 1 2 3 4 5 6 3  PH STAT R G R R G R R R - - - - - 4  VEH OVL - - - - - 5  PED OVL W W W W W W W W W W W W W 6  VEH CALL . I I . . . . . 7  PED CALL . . . . . 8  ACT TSP/SCP[0]  STATUS 1H 2H 3H 4H 5H 6H 9  PLAN SPLIT: 12 TP: 4 SEQ: 1 ACT:100 DP:4 10 LC: 6s/ 0 SC: 0s[ FREE]TLM ADD: 0 11 R1/PH 4 R2/PH 8 R3/PH . R4/PH . 12 MGR1 0.0 YEL 0.0 RED REST  RED REST 13 PDCL 12.0 FORCE OFF    14 FUNCTION 1 2 3 4 5 6 7 8 9 0 1 2 3 4 5 6 15 PMT/TSP  .  .  .  .  .  .  .  .  .  .  .  .  .  .  .  . 16 LP FLAG . A . . . A . . . . .                 </pre>	<p><b>When in a <span style="background-color: black; color: white;">hyperlink</span> field:</b></p> <p><b>To follow the hyperlink:</b></p> <p>For ASC/3, press <b>SPEC FUNC</b>, then <b>NEXT DATA</b>.</p> <p>For 2070, press <b>B</b>.</p> <p><b>To go back:</b></p> <p>For ASC/3, press <b>SUB MENU</b>.</p> <p>For 2070, press <b>ESC</b>.</p>
---	---

### Active Plan or State – Controller Status, MM-7-3-2, Line 1

For this information (same as in the Main Status Display), refer to the table *Active Plan or State—Controller Status (MM-7-1, MM-7-2, MM-7-3-1/2), Line 1* on page 12-3.

### Other Entries on Controller Status, Line 1

Current Controller *Date* in MM/DD/YY format

Current Controller *Time* in HH:MM:SS format

### Phase Status, in Order of Precedence – TSP/SCP Status, MM-7-3-2, Line 3

PH STAT	Definition
-	Phase is <i>not</i> enabled
N	Phase in Next
R	Phase is timing Red
Y	Phase is timing Yellow
y (lower case y) special	Protected Permitted Left Turn (PPLT) yellow
D	Phase is timing delay green
.	Phase is Red and not timing
G	Phase is Green

PH STAT	Definition
X	Simultaneous Red/Yellow (orange)
F# (special)	Canadian FF (future native feature) F1, F2, F3

#### Vehicle Overlaps – TSP/SCP Status, MM-7-3-2, Line 4

VEH OVL	Definition
-	Overlap is not programmed (omitted)
A	Overlap is timing Advance green
N	Overlap is next
Y	Overlap is timing Yellow
y (special)	Protected Permitted Left Turn (PPLT)
G	Overlap is green
F#	Flashing Green Overlap
L	Overlap is Timing Lagging green
R	Overlap is Red

#### Pedestrian Overlap Status (order of precedence) – TSP/SCP Status, MM-7-3-2, Line 5

PED OVL	Definition
-	PED is <i>not</i> enabled
N	PED is next
W	PED is timing/in WALK
C	PED is timing PED CLEAR
O	PED is Omitted
D	PED is in DON'T WALK

**Vehicle Call Information – TSP/SCP Status, MM-7-3-2, Line 6**

VEH CALL	Definition
O	Phase Omitted
E	Red extension call
C	Active vehicle detector call
B	Bike call
I	Call placed by internal application (Power Up, Preemptor, Keypad input)
N	Phase is non-actuated (CNA1, CNA2, Pre-timed)
F	Call placed by detector diagnostic (Failed Detector)
M	Max recall programmed for phase
R	Vehicle recall programmed for phase
X	Call placed by Max out
L	Locked vehicle detector call
S	Call placed by Soft recall or do not rest here
.	No phase demand

**To make a Vehicle Call:**

- 1** Go to MM-7-3-2, Line 4, VEH CALL.
- 2** Obey the applicable procedure, below.

To Make a Vehicle Call on:	Procedure
All Phases	<ol style="list-style-type: none"> <li><b>1</b> Move the cursor to the second L of VEH CALL</li> <li><b>2</b> Press <b>ENTER</b>.</li> </ol>
One Phase (range 1 thru 16)	<ol style="list-style-type: none"> <li><b>1</b> Move the cursor to the applicable phase, 1 thru 16.</li> <li><b>2</b> Press <b>ENTER</b>.</li> </ol>
One Phase (range 1 thru 10)	<ol style="list-style-type: none"> <li><b>1</b> Move the cursor to anywhere in the VEH CALL line.</li> <li><b>2</b> Press the applicable number key <b>1</b> thru <b>0</b>.</li> </ol>

**Note** • You can use the same procedure, above, to make a Vehicle Call from any status display that has the VEH CALL parameter.

**Pedestrian Call Information – TSP/SCP Status, MM-7-3-2, Line 7**

PED CALL	Definition
O	Ped Omitted
C	Active Pedestrian Detector Call
2	Active Pedestrian 2 Detector Call
I	Call placed by internal application (Power Up, Keypad input, Logic)
N	Pedestrian Phase is non-actuated (CNA1, CNA2, Pre-timed)
F	Call placed by detector diagnostic (Failed Detector)
R	Pedestrian Recall
L	Locked pedestrian call on the phase
.	No Pedestrian demand

**To make a Pedestrian Call:**

- 1** Go to MM-7-3-2, Line 5, PED CALL.
- 2** Obey the applicable procedure, below.

To Make a Pedestrian Call on:	Procedure
All Phases	<ol style="list-style-type: none"> <li><b>1</b> Move the cursor to the second L of PED CALL</li> <li><b>2</b> Press <b>ENTER</b>.</li> </ol>
One Phase (range 1 thru 16)	<ol style="list-style-type: none"> <li><b>1</b> Move the cursor to the applicable phase, 1 thru 16.</li> <li><b>2</b> Press <b>ENTER</b>.</li> </ol>
One Phase (range 1 thru 10)	<ol style="list-style-type: none"> <li><b>1</b> Move the cursor to anywhere in the PED CALL line.</li> <li><b>2</b> Press the applicable number key <b>1</b> thru <b>0</b>.</li> </ol>

**Note** • You can use the same procedure, above, to make a Pedestrian Call from any status display that has the PED CALL parameter.

Status Displays

- TSP/SCP Status Display, MM-7-3-2

**Active TSP/SCP Plan – TSP/SCP Status, MM-7-3-2, Line 8 (left side)**

Parameter	Definition	Range
ACT TSP/SCP	Number of the active TSP/SCP plan	1 thru 6

**TSP/SCP Plan Status – TSP/SCP Status, MM-7-3-2, Line 8 (right side)**

Parameter	Definition	Range
STATUS	<b>TSP Status for the TSP plans</b>	X = D, P, I, O, H, or E
1X	D = TSP/SCP Disabled	
2X	P = No valid TSP/SCP Pattern	
3X	I = TSP Phase inhibited	
4X	O = Omits on TSP/SCP phases	
5X	H = No TSP/SCP phases	
6X	E = Enabled and Idle	

**Current Controller Configuration – TSP/SCP Status, MM-7-3-2, Line 9**

**Hyperlink Fields**

Parameter	Definition	Range
PLAN SPLT:XXX	Plan Split Pattern Number	XXX = 001 thru 120
TP:XX	Timing Plan Number	XX = 01 thru 04
SEQ:XX	Sequence Page Number	XX = 01 thru 16
ACT:XXX	Action Plan Number	XXX = 001 thru 100
DP:X	Detector Plan Number	X = 1 thru 4



**Coordination-Specific Timing Information, TSP/SCP Status, MM-7-3-2, Line 10**

These are in four separate areas, as show below: Local Cycle Counter, System Cycle Counter, Current Coordination Status, and Highest Priority Telemetry Address

Parameter		Definition		Ranges	
LC:XXX+/YYY	Local Cycle Counter	XXX = counter	+ = s for seconds or % for percent	YYY = actual cycle length programmed	
SC:XXX+	System Cycle Counter (Master Clock)	XXX = counter	+ = s for seconds or % for percent		
<b>Current Coordination Status</b>					
FREE	Free	N/A			
SYNC	Sync Pulse				
PICKUP	In pickup mode				
COORD	Coordinated (in step)				
DWELL	Dwelling / Transition				
ADDONLY	Add Only Transition				
DEDUCT	Subtracting in Smooth Transition				
ADDING	Adding in Smooth Transition				
<b>Highest Priority Telemetry Address</b>					
TLM ADD XXXXX	Highest Priority Telemetry Address	XXXXX = 0 thru 65535			

**Ring and Active Phase for the Ring – TSP/SCP Status, MM-7-3-2, Line 11**

If a Ring is NOT active, the phase is a “.”

Parameter		Definition		Ranges	
RX/PH	YY	Ring Number/Active Phase	X = 1 thru 4	YY = 1 thru 16	

For example, R1/PH 4 | R2/PH 8 | R3/PH . | R4/PH .

shows that Ring 1 has active phase 4 | Ring 2 has active phase 8 | Ring 3 is not active | Ring 4 is not active

- TSP/SCP Status Display, MM-7-3-2

**Active Phase Timing and Intervals – TSP/SCP Status, MM-7-3-2, Line 12**

**Note** • For a timer, the timer value is shown to its right.

Parameter	Definition
EXT1	Green vehicle extension
EXT2	Green vehicle extension 2
GAPr	Gap reduction is in effect
GRNp	Preemptor minimum green override
GRN HOLD	Phase in HOLD interval
GRN REST	Phase rests in absence of calls
GRN XFER	Phase awaits timeout of another phase
INACTIVE	Ring is inactive
MGRN1	Minimum Green
MGRN2	Bike minimum green
MGRa	Additional Initial Green
MGRNd	Delay green for early walk
MGRNc	Conditional Service minimum green
MGRNg	Guaranteed minimum green
PED ONLY	Phase is timing pedestrian timing only
RED-	Vehicle red clearance
RED REST	Red rest
REDg	Guaranteed red clearance
REDp	Preemptor red override
RED EXTEND	Phase is timing red extension
RED XFER	Phase is in red transfer
RRVT	Phase is next but its red revert is timing
YEL-	Vehicle yellow change

Parameter	Definition
YELg	Guaranteed yellow change
YELp	Preemptor yellow override

### Phase Termination Timing, TSP/SCP Status, MM-7-3-2, Line 13

When a phase is terminated (during yellow change and red clearance), the reason for the termination is shown here.

Parameter	Definition
FORCE OFF	Terminated by command or force-off signal
GAP OUT	Gap between vehicles exceeded gap-out limit in effect in volume density operation
GUAR PASS	Full vehicle extension timed after time out of reduced gap
MAN ADV	Terminated by manual advance
MAX1	Max 1 is timing
MAX2	Max 2 is timing
MAX3	Max 3 is timing
MAXD	Max Dynamic is timing
MAX OUT	Green ext time reached its maximum limit
MAX GAP	Minimum gap was in effect when gap-out occurred
PC-1	Ped Clear 1 is timing
PC-2	Ped Clear 2 is timing
PC-G	Guarantee Ped Clear is timing
PC-M	Ped Clear Max is timing
PC-P	Preemptor is timing Ped Clear
PREEMPT	Terminated by preemption
REDm	Vehicle red clearance maximum
SPLT	SPLT: Coordinator or TSP/SCP split timing is being used for the phase MAX time.
TSP	TSP Split is timing

**Status Displays**

- *TSP/SCP Status Display, MM-7-3-2*

Parameter	Definition
WK-1	Walk 1 is timing
WK-G	Guarantee Walk is timing
WALK HOLD	The phase is in Walk Hold
WALK REST	The Phase is in Green Reset
WK-2	Walk 2 is timing
WLFT	Pre Time Walk (FT) is timing
WL-P	Preemptor is timing walk
WK-M	Walk max is timing

**Preemptor (PMT) & Transit Signal Priority (TSP) Input Status  
TSP/SCP Status, MM-7-3-2, Line 15**

10 possible Preempts (1 thru 10) are on the left, and 6 possible TSPs (1 thru 6) are on the right

PMT/TSP	Definition
<b>PMT Status (left 1 thru 10)</b>	
-	Not Programmed
R	Re-service period
I	Preemptor is Inhibited
D	Delay timer is running for that preempt
A	Preempt run is active
C	Call, but that preempt is not yet active
.	Preempt is programmed/enabled, but there is no activity on it

PMT/TSP	Definition
<b>TSP Input Status (right 1 thru 6)</b>	
-	Disabled
X	TSP is not programmed correctly (omits on TSP phases, no TSP pattern, no TSP phases)
R	Re-service period
I	Inhibited
A	Call is being served
N	NTCIP Commanded
C	Call from inputs
.	Enabled, but there is no activity on it
G	A TSP phase is timing in early or Extended Green

### TSP/SCP Field Testing

#### To test operation and place a manual TSP/SCP call:

- 1** Go to MM-7-3-2.
- 2** Move the cursor to the applicable TSP input field on the PMT/TSP row, Line 15.
- 3** Press **ENTER** and hold the key down. This will apply a continuous pulsing signal to the designated TSP input, simulating a TSP call.

### Logic Processor Flag Status, TSP/SCP Status, MM-7-3-2, Line 16

16 possible Logic Processor Flags, 1 thru 16

LP FLAG	Definition
A	Active
.	Inactive
-	Not used

## Time Base Status Display, MM-7-4

Shows the current schedule, day plan, event and the corresponding start time and action plan if a Time Base Control (TBC) day plan is in effect. The next 9 events and their corresponding schedule, day plan, event start time and action plan are also shown.

1	TIME BASE STATUS WED 2-28-07 10:44:00 ▼						
2	SOURCE...TIME BASE			NEXT DAY PLAN:FRI			
3	#	SCHDL	DAY	PLN DP	EVENT	ACT	PLN START
4	1	1	WED	1	5	4	109:10
5	2	1	WED	1	6	5	111:45
6	3	1	WED	1	7	10	114:20
7	4	1	WED	1	12	2	115:45
8	5	1	WED	1	2	4	119:15
9	6	1	WED	1	1	1	121:00
10	7	1	THU	1	5	4	109:00
11	8	1	THU	1	6	5	111:45
12	9	1	THU	1	7	10	114:20
13	10	1	THU	1	12	2	115:45
14	11	1	THU	1	2	4	119:15
15	12	1	THU	1	1	1	121:00
16	13	0	----	0	0	0	100:00
17	14	0	----	0	0	0	100:00
18	15	0	----	0	0	0	100:00
19	16	0	----	0	0	0	100:00
20	17	0	----	0	0	0	100:00
21	18	0	----	0	0	0	100:00
22	19	0	----	0	0	0	100:00
23	20	0	----	0	0	0	100:00
24	21	0	----	0	0	0	100:00
25	22	0	----	0	0	0	100:00
26	23	0	----	0	0	0	100:00
27	24	0	----	0	0	0	100:00
28	25	0	----	0	0	0	100:00
29	26	0	----	0	0	0	100:00
30	27	0	----	0	0	0	100:00
31	28	0	----	0	0	0	100:00
32	29	0	----	0	0	0	100:00
33	30	0	----	0	0	0	100:00

When in a **hyperlink** field:

To follow the hyperlink:

For ASC/3, press **SPEC FUNC**, then **NEXT DATA**.

For 2070, press **B**.

To go back:

For ASC/3, press **SUB MENU**.

For 2070, press **ESC**.

### Time Base Status, MM-7-4, Line 1

Current Controller *Date* in MM/DD/YY format

Current Controller *Time* in HH:MM:SS format

**Source of Command, Time Base Status, MM-7-4, Line 2 (left side)**

SOURCE	Definition
MANUAL	Source of Command is Manual
HOLIDAY	Source of Command is based on Holiday schedule
TIMEBASE	Source of Command is based on Timebase schedule
TELEMETRY	Source of Command is based on Telemetry

**Next Day Plan, Time Base Status, MM-7-4, Line 2 (right side)**

Parameter	Definition	Range
NEXT DAY PLAN	The next scheduled day plan	Day of the Week, SUN thru SAT

**Entries on Time Base Status, MM-7-4, Line 2 (right side)**

Current Controller *Date* in MM/DD/YY format

Current Controller *Time* in HH:MM:SS format

**Schedule Commands 1 thru 30, Time Base Status, MM-7-4, Lines 4 thru 33 (column 1)**

Parameter	Definition	Range
SCHDL	<p><b>Schedule</b></p> <p>When this Schedule is programmed, it overrides the schedule selected from the schedule plan in MM-5-2. When the Schedule command is in effect, the screen only shows the events, start times and action plans of the day plan in effect.</p>	0 thru 200

**Day Plan, Time Base Status, MM-7-4, Lines 4 thru 33 (column 2)**

Parameter	Definition	Range
DAY PLN	<p><b>Day Plan</b></p> <p>When this Day Plan is programmed, it overrides the other day plan commands. When the Day Plan command is in effect, the screen only shows the events, start times and action plans of the day plan in effect.</p>	0 thru 16

- Time Base Status Display, MM-7-4

**Day Plan Event Command, Time Base Status, MM-7-4, Lines 4 thru 33 (column 3)**

Parameter	Definition	Range
DP EVENT	<p><b>Day Plan Event Command</b></p> <p>This must be an event in the day plan in effect. When programmed, it overrides the current event selected by the time-of-day.</p>	0 thru 16

**Action Plan, Time Base Status, MM-7-4, Lines 4 thru 33 (column 4)**

Parameter	Definition	Range
ACT PLN	<p><b>Action Plan Command</b></p> <p>This overrides any other action plan commands.</p>	0 thru 100

**Day Plan Event Start Time, Time Base Status, MM-7-4, Lines 4 thru 33 (column 5)**

Parameter	Definition	Range
START	<p><b>Day Plan event start time</b></p> <p>This is the start time of the Day Plan, scheduled in MM-5-3. Once selected, the day plan will stay in effect until another Day Plan Event is selected. Refer to NTCIP 1201 2.4.4.3.</p>	<p>Time</p> <p>00:00 thru 23:59 (hour and minute)</p>



## Communications Submenu, MM-7-5

COMMUNICATIONS SUBMENU	
1. ETHERNET	5. NTCIP
2. PORT 2/C50S	6. ECPIP
3. PORT 3A/C21S	7. IEEE 1570
4. PORT 3B/C22S	

This display lists seven communications status data display groups that are briefly described below. This menu and the displays for Serial Ports are applicable to *ASC/3* and *2070* controllers, unless otherwise indicated.

For your convenience, all Communications Status displays are hyperlinked to their related Configuration displays.

### *Ethernet Communication Status, MM-7-5-1*

ETHERNET	THU 02/07/12   17:48:30
MAC ADDRESS.....	
00:00:00:00:00:00	
LINK SPEED/DUPLEX.....	100/FULL
RX PACKET COUNT.....	65535
TX PACKET COUNT.....	65535
RX PACKET ERROR COUNT.....	65535
TX PACKET ERROR COUNT.....	65535
DEFAULT GATEWAY REACHABLE.....	YES
SERVER REACHABLE.....	
YES	

#### To reset some parameters:

- ▶ Press **CLEAR** — for *2070*, press **C**

- Ports 2/C50S, 3A/C21S, 3B/C22S Status

MM-7-5-1 Parameter	Description
MAC ADDRESS	The Media Access Control (MAC) address uniquely identifies the Controller Unit on Ethernet networks. It is factory-programmed and can NOT be changed.
LINK SPEED/DUPLEX	Interface bandwidth in bits per second. The link speed and duplex setting is auto-negotiated when the controller is connected to an Ethernet network in the order that follows:  100/FULL  100/HALF  10/FULL  10/HALF
RX PACKET COUNT	Total packets Received on the interface
TX PACKET COUNT	Total packets Transmitted on the interface
RX PACKET ERROR COUNT	The number of Inbound packets that contained errors
TX PACKET ERROR COUNT	The number of Outbound packets that could NOT be transmitted
DEFAULT GATEWAY REACHABLE	The default gateway (configured in MM-1-5-1) has received and responded to an ICMP ping packet
SERVER REACHABLE	The server (configured in MM-1-5-1) has received and responded to an ICMP ping packet

### Ports 2/C50S, 3A/C21S, 3B/C22S Status

Serial Ports generally have similar functions, but their front-panel connectors are different. ASC/3 serial ports:

- Can operate in the same four Protocols (ECP/IP, TERMINAL, NTCIP and AB3418) and
- The information is in the same format in each status display, with Port status on the left and Protocol status on the right.

---

**Note** • The 2070 serial ports have Protocol limitations, which are shown at the bottom of the display, when applicable.

---

**To select the Protocol:**

- 1 Go to the configuration display for the communication port — for example, MM-1-5-2 for Port 2/C50S or MM-1-5-3 for Port 3A/C21S.
- 2 Toggle the PROTOCOL parameter to the applicable Protocol (ECPIP, TERMINAL, NTCIP or AB3418).

The status display then uses the Protocol selected during controller configuration to adjust the status display to show the relevant and/or supported fields. Each display has its status in a 2-column format: the left column shows Port status and the right column shows Protocol status.

The sections that follow give:

- The Port fields for each platform
- A description of the common Protocol variations
- A description of the global NTCIP and ECPIP Protocol status displays. This is because they contain communications status information that is not port-specific.

**Serial Ports with Terminal Protocol, Status Displays**

ASC/3 Ports	2070 Ports
MM-7-5-2, Port 2	MM-7-5-2, Port C50S
<pre> COMM PORT 2      NNN DD/MM/YY HH:MM:SS RECEIVE..... X PROTOCOL..... TERM TRANSMIT..... X RX BYTE COUNT. 65535 READY TO SEND... X TX BYTE COUNT. 65535 CLEAR TO SEND... X DATA TERM READY.. X DATA SET READY... X CARRIER DETECT... X                     </pre>	<pre> COMM PORT C50S   NNN DD/MM/YY HH:MM:SS RECEIVE..... X PROTOCOL..... TERM TRANSMIT..... X                     </pre>

## Status Displays

- Ports 2/C50S, 3A/C21S, 3B/C22S Status

ASC/3 Ports	2070 Ports
MM 7-5-3, Port 3A	MM 7-5-3, Port C21S
<pre> COMM PORT 3A      NNN DD/MM/YY HH:MM:SS RECEIVE..... X PROTOCOL..... TERM TRANSMIT..... X RX BYTE COUNT. 65535 READY TO SEND... X TX BYTE COUNT. 65535 CARRIER DETECT... X           </pre>	<pre> COMM PORT C21S   NNN DD/MM/YY HH:MM:SS RECEIVE..... X PROTOCOL..... TERM TRANSMIT..... X RX BYTE COUNT. 65535 READY TO SEND... X TX BYTE COUNT. 65535 CLEAR TO SEND... X DATA TERM READY.. X DATA SET READY... X CARRIER DETECT... X           </pre>
<p><b>Note</b> • Port 3A does NOT have the RS-232 flow control lines listed below. Thus, these status fields are not shown:</p> <p style="padding-left: 40px;">CLEAR TO SEND DATA TERM READY DATA SET READY</p>	
MM 7-5-4 Port 3B	MM 7-5-4 Port C22S
<pre> COMM PORT 3B      NNN DD/MM/YY HH:MM:SS RECEIVE..... X PROTOCOL..... TERM TRANSMIT..... X RX BYTE COUNT. 65535 READY TO SEND... X TX BYTE COUNT. 65535 CLEAR TO SEND... X DATA TERM READY.. X DATA SET READY... X CARRIER DETECT... X           </pre>	<pre> COMM PORT C22S   NNN DD/MM/YY HH:MM:SS RECEIVE..... X PROTOCOL..... TERM TRANSMIT..... X RX BYTE COUNT. 65535 READY TO SEND... X TX BYTE COUNT. 65535 CLEAR TO SEND... X DATA TERM READY.. X DATA SET READY... X CARRIER DETECT... X           </pre>

## Parameters for Serial Port Status Displays

Parameter	Definition
<b>Port Status</b>	
RECEIVE	The state of the RXD input signal
TRANSMIT	The state of the TXD output signal
READY TO SEND	The state of the RTS output signal
CLEAR TO SEND	The state of the CTS input signal
DATA TERM READY	The state of the DTR output signal
DATA SET READY	The state of the DSR input signal
CARRIER DETECT	The state of the CD input signal

Parameter	Definition
<b>Protocol Status</b>	
RX BYTE COUNT	Number of characters received
TX BYTE COUNT	Number of characters transmitted

### Serial Port Status Displays with Other Protocols

The protocol variations that follow are shown with Port 2/C50S and Port 3A/C21S. However, the protocol-specific fields in the right column are applicable to all serial port status displays, if they are supported by that port and platform. Refer to Appendix B, *ASC/3 Screens*, for other combinations.

ASC/3 Ports	2070 Ports
<b>MM-7-5-2 Port 2 (NTCIP with ASC/3-IM)</b>	<b>MM 7-5-2 Port C50S (NTCIP)</b>
<p><b>Note</b> • Port 2 is the only port that supports the ASC/3 Intersection Monitor (ASC/3-IM) feature.</p> <pre> COMM PORT 2      NNN DD/MM/YY HH:MM:SS RECEIVE..... X PROTOCOL..... NTCIP TRANSMIT..... X RX BYTE COUNT. 65535 READY TO SEND... X TX BYTE COUNT. 65535 CLEAR TO SEND... X DROP-OUT TIMER 65535 DATA TERM READY.. X DATA SET READY... X CARRIER DETECT... X  INTERSECTION MONITOR: COMMAND MODEM ANSWER..... X                     </pre>	
<b>MM-7-5-3 Port 3A (ECPIP)</b>	<b>MM-7-5-3 Port C21S (ECPIP)</b>
<pre> COMM PORT 3A      NNN DD/MM/YY HH:MM:SS RECEIVE..... X PROTOCOL..... ECPIP TRANSMIT..... X RX BYTE COUNT. 65535 READY TO SEND... X TX BYTE COUNT. 65536 CARRIER DETECT... X DROP-OUT TIMER 65535                     </pre>	This is <i>not</i> supported.
<b>MM-7-5-2 Port 2 (AB3418)</b>	<b>MM-7-5-2 Port C50S (AB3418)</b>
<pre> COMM PORT 2      NNN DD/MM/YY HH:MM:SS RECEIVE..... X PROTOCOL..... AB3418 TRANSMIT..... X RX BYTE COUNT. 65535 READY TO SEND... X TX BYTE COUNT. 65535 CLEAR TO SEND... X DROP-OUT TIMER 65535 DATA TERM READY.. X DATA SET READY... X CARRIER DETECT... X                     </pre>	<pre> COMM PORT C50S    NNN DD/MM/YY HH:MM:SS RECEIVE..... X PROTOCOL..... AB3418 TRANSMIT..... X RX BYTE COUNT. 65535                     X TX BYTE COUNT. 65535                     </pre>

## Status Displays

- Ports 2/C50S, 3A/C21S, 3B/C22S Status

Parameter	Definition
<b>MM-7-5-2, Port 2 (NTCIP with ASC/3-IM)</b>	
COMMAND MODEM ANSWER	Manually command the <i>ASC/3</i> to answer an incoming <i>ASC/3</i> Intersection Monitor ( <i>ASC/3-IM</i> ) phone call. Press <b>ENTER</b> to take the phone off-hook. The 'X' will clear when the request is processed. If you do NOT have the <i>ASC/3-IM</i> feature enabled, the request will remain pending.
<b>MM-7-5-2, Port C50S (NTCIP)</b>	
PROTOCOL	Provides an NTCIP-compatible connection between computers and modems. This protocol is designed to function in an NTCIP System.
DROP-OUT TIMER	The time from the last valid command before the port goes back to local control
<b>MM-7-5-3, Port 3A (ECPIP)</b>	
PROTOCOL	Provides an ECPIP-compatible connection between computers, modems and Zone Masters. This protocol is designed to function in an Econolite Aries or Zone Master System
<b>MM-7-5-2, Port 2/C50S (AB3418)</b>	
PROTOCOL	Supplies an AB4318-compatible connection between computers and modems. This protocol is designed to comply with the California AB3418 specification.

### NTCIP Status Screen, MM-7-5-5

```

NTCIP                NNN MM/DD/YY|HH:MM:SS
                   1 2 3 4 5 6 7 8 9 0 1 2 3
DYNAMIC OBJ        X X X X X X X X X X X X X
SPECIAL FUNC       X X X X X X X X X
RX SNMP MESSAGE COUNT..... 65535
TX SNMP MESSAGE COUNT..... 65535
RX STMP MESSAGE COUNT..... 65535
TX STMP MESSAGE COUNT..... 65535
ACTIVE CONTROL PORT..... C50S
LAST TIME SYNC..... 65535
DATABASE STATE..... ALL SAVED
CONFIGURATION TRANSFER IN PROGRESS. NO
    
```

The Communications Status displays for the NTCIP and AB3418 protocols are identical, except for the PROTOCOL value shown. The NTCIP version is shown above. The AB3418 version is the same except that AB3418 is shown as the PROTOCOL value. For definitions of the parameters in this display, refer to the table that follows.

MM-7-5-5 Parameter	Description
DYNAMIC OBJ	Status fields representing which dynamic objects are valid (X) or invalid (.) (“under creation” is not shown because it is a transient state).  There are 13 total dynamic objects.
SPECIAL FUNC	The current status of the special function output (logical or physical) in the device.  X = ON “.” = OFF
RX SNMP MESSAGE COUNT	The total number of Messages delivered to the SNMP entity from the transport service.
TX SNMP MESSAGE COUNT	The total number of SNMP Messages that were passed from the SNMP protocol entity to the transport service.
RX STMP MESSAGE COUNT	The total number of Messages delivered to the STMP entity from the transport service.
TX STMP MESSAGE COUNT	The total number of STMP Messages that were passed from the SNMP protocol entity to the transport service.
ACTIVE CONTORL PORT	This field identifies which hardware port is currently in control of the Command Objects.
LAST TIME SYNC	Seconds since last time sync was received.

- *ECPIP Status Screen, MM-7-5-6*

MM-7-5-5 Parameter	Description
DATABASE STATE	<p><b>ALL SAVED:</b> Database changes have been saved to the NVRAM and files.</p> <p><b>SAVED TO NVRAM:</b> Database changes have been saved to the NVRAM and are being saved to the files.</p> <p><b>SAVING - WAIT:</b> Database changes are pending to be saved to NVRAM and files.</p> <p><b>ACQUIRED BY NTCIP:</b> Database has been acquired by NTCIP command.</p> <p><b>ACQUIRED BY USER:</b> Database has been acquired by user - using key sequences or making changes from the keyboard.</p> <p><b>ACQUIRED BY ECPIP:</b> Database has been acquired by ECPIP command.</p>
CONFIGURATION TRANSFER IN PROGRESS	Indicates if a configuration transfer is in progress (no, up, or down). Controller configuration transfers are done over ECPIP or NTCIP or AB3418 (e.g. <i>Aries</i> or <i>icons</i> or <i>Centrac</i> s).

*ECPIP Status Screen, MM-7-5-6*

```

ECPIP                NNN DD/MM/YY|HH:MM:SS
                   1 2 3 4 5 6 7
TELEMETRY MODE      X X X X X X X
SPECIAL FUNCTION    X X X X
RX MESSAGE COUNT..... 65535
TX MESSAGE COUNT..... 65535
RX MESSAGE ERROR COUNT..... 65535
TX MESSAGE ERROR COUNT..... 65535
LAST VALID COMMAND..... 65535

LAST TIME SYNC..... 65535
CONFIGURATION TRANSFER IN PROGRESS.  NO
    
```

**To reset some parameters:**

- ▶ Press **CLEAR** — for 2070, press **C**.



The Communications Status display for the ECPIP protocol gives Activity, Timing, Mode, and Special Functions information. For definitions of the parameters in this display, refer to the table that follows.

MM-7-5-6 Parameter	Description
TELEMETRY MODE	<p><b>X:</b> Indicates these Telemetry Modes have been downloaded to this controller:</p> <p><b>1</b> = Dual Coordination  <b>2</b> = Flash  <b>3</b> = Free  <b>4</b> = Max Recall  <b>5, 6, and 7</b> = Spare</p>
SPECIAL FUNCTIONS	<p><b>X:</b> Indicates these Special Functions have been downloaded to all addresses:</p> <p><b>1</b> = System Flash  <b>2, 3, and 4</b> = Spare</p>
RX MESSAGE COUNT	Number of valid ECPIP messages received
TX MESSAGE COUNT	Number of valid ECPIP messages transmitted
RX MESSAGE ERROR COUNT	Number of invalid ECPIP messages received
TX MESSAGE ERROR COUNT	Number of invalid ECPIP messages transmitted
LAST VALID COMMAND	Seconds since last valid command was received
LAST TIME SYNC	Seconds since last time sync was received
CONFIGURATION TRANSFER IN PROGRESS	Indicates if a configuration transfer is in progress (up or down). Controller configuration transfers are done over ECPIP or NTCIP or AB3418 (e.g. <i>Aries</i> or <i>icons</i> or <i>Centracs</i> ).

### IEEE 1570 Status, MM-7-5-7

Refer to the *IEEE 1570 User Guide*, P/N 100-0903-008, for complete a description of the Status screen.

## Detector Status Display, MM-7-6

This display has status display positions for all detectors (01-64).

```

DETECTOR STATUS          02/12/08|07:09:40
DET [ 5]TIME  0.0   DELAY 0.0 EXTEND 0.0
DET DIAG|CTR:MAX PRES |TS2:Excess Change
DET PH   1  2  3  4  5  6  7  8  9  0  1  2  3  4  5  6
 1   1   . . . . . C . . C 01-08
    01-08 . . . . . . . . . 09-16
    09-16 . . . . . . . . . 17-24
    17-24 . . . . . . . . . 25-32
    25-32 . . . . . . . . . 33-40
    33-40 - - - - - - - - - 41-48
    41-48 - - - - - - - - - 49-56
    49-56 - - - - - - - - - 57-64
    57-64 - - - - - - - - -
    
```

When in a **hyperlink** field:

**To follow the hyperlink:**

For ASC/3, press **SPEC FUNC**, then **NEXT DATA**.

For 2070, press **B**.

**To go back:**

For ASC/3, press **SUB MENU**.

For 2070, press **ESC**.

**To know the status of a detector:**

- 1 Move the cursor to a programmed detector.
- 2 To simulate the detector call, press **ENTER**.

Beep sound: Indicates when the raw detector is active.

MM-7-6 Parameter	Description	Range
DET	<p><b>Vehicle Detector Number (NTCIP 1202 2.3.2.1)</b></p> <p>To view its status or edit, enter the number of a detector.</p> <p><b>Note</b> • This is a hyperlink field, linked to MM-6-2, the Vehicle Detector Setup for this Detector.</p>	1-64
TIME	<p>When the detector is being delayed, extending, or is a speed detector, the value is displayed:</p> <p>0.0-255.0: DELAY countdown, in sec.</p> <p>0.0-25.5: EXTEND countdown, in sec.</p> <p>0-99: The last speed recorded, in MPH</p>	Refer to the ranges given in the column to the left.
DELAY	<p><b>Detector Delay Time (NTCIP 1202 2.3.2.5)</b></p> <p>Defines the time that the raw detector input is ignored or delayed when the assigned phase is not green.</p>	0.0-255.0 sec.

MM-7-6 Parameter	Description	Range
EXTEND	<p><b>Detector Extend Time (NTCIP 1202 2.3.2.6)</b></p> <p>Defines the time that a passage detector extends the assigned phase after termination of the input.</p> <p><b>Note</b> • The assigned phase may also be extended additionally by the phase extension time (MM-2-1).</p>	0.0-255.0 sec.
DET PH	<p><b>Phases Called by this Detector</b></p> <p>Range: X, “.”</p> <p>Read only configuration status of this detector that calls and extends phases in addition to the assigned phase.</p>	X “.”
01 thru 64	<p>The indications below are in order of precedence.</p> <p>Detector 01-64:</p> <p><b>F:</b> Failed diagnostics</p> <p><b>D:</b> Delay is timing</p> <p><b>E:</b> Extend is timing</p> <p><b>C:</b> Active call with no delay or extend</p> <p><b>L:</b> Locked call on the detector input</p> <p><b>S:</b> Speed detector</p> <p>“.”: No activity</p> <p>“-”: Not programmed, assigned or enabled</p>	F D E C L S “.” “-”

- *Flash/SDLC/MMU Status Display, MM-7-7*

## Flash/SDLC/MMU Status Display, MM-7-7

```
FLASH/SDLC/MMU STATUS

1. FLASH STATUS

2. SDLC STATUS

3. MMU STATUS

4. MMU EXTENDED STATUS

5. MMU AC STATUS

6. MMU COMPATIBILITY STATUS
```

### *Flash Status Display, MM-7-7-1*

```
FLASH STATUS:
AUTOMATIC FLASH

AUTO FLASH REMOTE INPUT

RING 1
RING 2
```

MM-7-7-1 shows the cause of a cabinet Flash condition. The example above is for an Automatic Flash condition. If there is no flash condition, MM-7-7-1 shows NO FLASH ACTIVE.

**Note** • There may be many flash conditions that are true at the same time.

15 Flash Categories	Abbreviations in Flash Status Messages
0 = No Flash Active	CFM: Controller Fault Monitor
1 = Power-ON Flash	CMU: Conflict Monitor Unit
2 = MMU-initiated flash	CRC: Cyclical Redundancy Check
3 = CMU-initiated flash	CVM: Controller Voltage Monitor
4 = Controller-initiated CVM flash	FIO: Field Input and Output
5 = External Start during Preemption	IDOT: Illinois Department of Transportation
6 = Fault flash	MIN: Minimum
7 = 3 Critical Errors in 24 hours	MON: Monitor
8 = Preemption programmed CVM flash	MMU: Malfunction Management Unit
9 = Cabinet Local Flash	NEMA: National Electrical Manufacturers Association
10 = Preemption-programmed flash	PGM'D: Programmed
11 = Automatic/Remote flash	RFE: Response Frame Error
12 = FIO card failed or missing (2070)	SDLC: Synchronous Data Link Control
13 = Database FIO type mismatch (2070)	TF: Terminal and Facilities
14 = Unknown flash source	TLM: Telemetry

The information in the 15 categories of flash displays is described in the table below.

### Flash Display Information, MM-7-7-1

MM-7-7-1 Parameter	Description
<b>Category 0, No Flash Active</b>	
<b>NO FLASH ACTIVE</b>	
<b>Category 1, Power-ON Flash</b>	
<b>POWER ON FLASH</b>	
TIMING POWER-ON FLASH	The controller is timing Power-ON Flash that was previously programmed. Refer to <i>Start/Flash Data, MM-2-5</i> on page 7-20.

## Status Displays

- Flash Status Display, MM-7-7-1

MM-7-7-1 Parameter	Description
TIMING POWER-ON ALL RED (NO FLASH)	This was programmed in MM-2-5.  Although POWER-ON ALL RED is NOT a flash Condition, it is shown because the controller is still in the Power-On interval.
EXTERNAL START	Flash caused by External Start Input. At power ON to the Controller, the External Start Input is TRUE and preempt is active. External Start Input is programmed in the controller submenu, Start/Flash Data (MM-2-5).
PREEMPTOR CALL INPUT	Flash caused by Active Preempt Input. This indicates the conditions were TRUE when the Controller started.
PREEMPTOR CALL INPUT FROM KEYBOARD	Flash caused by Active Preempt Input, activated from the keypads. This indicates the conditions were TRUE when the Controller started.
MMU OUTPUT RELAY TRANSFERED	MMU is in the flash state
<b>Category 2, MMU-Initiated Flash</b> These error conditions are as reported by the MMU.	
<b>MMU CRITICAL ERROR FLASH - FROM RF129</b>	
CONTROLLER VOLTAGE MONITOR	The MMU detected a Controller Voltage Monitor/ Controller Fault Monitor failure.
+24 VOLTAGE MONITOR I	The MMU detected a +24 Volt Monitor I failure.
+24 VOLTAGE MONITOR II	The MMU detected a +24 Volt Monitor II failure.
COLOR CONFLICT	Indicates that a color conflict at an intersection caused the flash condition. The flash status display indicates, with X, the status of all channels by phase color (red, yellow, green) at the time the conflict occurred.  An X is shown under each active channel and next to the corresponding color.  Conflicts can be observed by comparing the phases and colors. Channel and phase relationships are determined by the phase-to-load-switch assignment programmed at the controller.

MM-7-7-1 Parameter	Description
RED FAILURE	A red indication was not given when it should have been. The flash status display shows an X under each channel and next to the phase color. To identify red failure, check for X on red on all movements that should indicate red.
MMU DIAGNOSTIC FAILURE	The MMU has detected that it has a diagnostic failure. The Controller is alerted.
MINIMUM CLEARANCE FAILURE	The minimum clearance time (yellow) was not long enough.
PORT 1 TIME OUT	The MMU detected a failure from the controller. Possible causes for this failure include: interrupted communications between controller and MMU.
<b>Category 3, CMU-INITIATED FLASH</b>	
<b>CMU CRITICAL ERROR FLASH</b>	
<b>Category 4, CONTROLLER-INITIATED CVM FLASH</b> Controller Voltage Monitor (CVM)/Controller Fault Monitor (CFM) failure has caused the flash condition	
<b>CRITICAL ERROR FLASH — ASC/3-GENERATED</b>	
MEMORY ERROR	Memory diagnostics have detected a hardware memory failure or loss of critical information related to critical stored data.
CRITICAL PREEMPT ERROR	The Preemptor detected a critical preemption-related error condition (Interlock Fail, Gate Down, etc.)
CYCLE FAILURE ERROR	A cycle failure occurs when there are calls present on a phase that has not been serviced for 2 cycles. Keyboard reset clears the flash condition.
IDOT CRC CHECK FAILURE	IDOT CRC is enabled and one of these two possible failures occurred: <ul style="list-style-type: none"> <li>■ An intersection failed the IDOT CRC test at power-ON.</li> <li style="text-align: center;"><b>Or</b></li> <li>■ The CRC of data entered in Supervisor mode did NOT match the IDOT hardwired CRC inputs.</li> </ul>

- Flash Status Display, MM-7-7-1

MM-7-7-1 Parameter	Description
COMPATIBILITY ERROR	<p>The program on the MMU program card and the MMU program entered at the controller do not match. The fault status display shows the channel number(s) where there is a mismatch, the controller state (0,1), and MMU state (0 or 1).</p> <p>The MMU program card should be pulled from the cabinet to verify (using the Software Modules display, MM-8-7) whether the controller program or the MMU program must be corrected, as applicable.</p> <p>If COMPATIBILITY ERROR is indicated, MM-7-7-6 shows which bits within SDLC response frame 131 (refer to NEMA TS2-2003, - 3.3.1.4.2.3) are in conflict with programming on MM-1-4-2.</p>
COLOR MISMATCH	<p>A color difference was detected between the colors generated by the controller and the channel colors returned by the MMU. The flash status display shows the controller read-back of the MMU channels and phase colors. An X appears below each channel and next to its associated phase color. The conflict is summarized at the bottom of the display where the channel numbers, mismatched output and MMU colors are indicated. Each color mismatch will show a two-digit channel number (01-16) followed by two letters (G for green, Y for yellow, R for red and N for no color). The first letter represents the channel color sent by the controller and the second the channel color seen by the MMU.</p> <p><b>Example:</b> 13GN indicates channel 13, output color = Green, MMU color = No color).</p> <p>There is a display similar to that shown below.</p> <p>Color mismatch is by channel, by color. So it is possible to see a display for Channel 01 as shown below:</p> <p>COLOR MISMATCH</p> <p>01GN 01NY 01NR 12GY, etc.</p> <p>Channel and phase relationships are determined by the phase-to-load-switch assignment programmed at the controller. Keyboard reset clears flash condition.</p>



MM-7-7-1 Parameter	Description
<b>Category 5, External Start During Preemption</b>	
<b>EXTERNAL START DURING PREEMPT</b>	
PREEMPT CALL INPUT	Can <i>not</i> exit flash state because a Preemption Call input is active.
PREEMPT CALL INPUT FROM KEYBOARD	Can <i>not</i> exit flash state because a Keyboard-entered Preemption Call is active.
<b>Category 6, Fault Flash</b>	
<b>FAULT FLASH</b>	
RFE 128	Flagged if 6 or more out of the last 10 frames (in a second) are not correctly received
RFE 129	Flagged if 6 or more out of the last 10 frames (in a second) are not correctly received
RFE 131	Flagged if 6 or more out of the last 10 frames (in a second) are not correctly received
RFE 138	Flagged if 6 or more out of the last 10 frames (in a second) are not correctly received
RFE 139	Flagged if 6 or more out of the last 10 frames (in a second) are not correctly received
RFE 140	Flagged if 6 or more out of the last 10 frames (in a second) are not correctly received
RFE 141	Flagged if 6 or more out of the last 10 frames (in a second) are not correctly received
3 CRITICAL ERRORS IN 24 HOURS	Flagged if 3 critical RFE errors happened in 24 hours.
<b>Category 7, 3 Critical Errors in 24 Hours</b>	
<b>3 CRITICAL ERRORS IN 24 HOURS</b>	
<b>Category 8, Preemption Programmed Controller Voltage Monitor (CVM) Flash</b>	
<b>PREEMPT PGM'D CVM FLASH</b>	

Status Displays

- Flash Status Display, MM-7-7-1

MM-7-7-1 Parameter	Description
<b>Category 9, Cabinet Local Flash</b>	
LOCAL FLASH INPUT	The local flash input from the cabinet is active. <b>Example:</b> Police switch at the cabinet.
<b>Category 10, Preemption-Programmed Flash</b>	
PREEMPT PGM'D FLASH	Preemptor program is calling for flash as part of the preemption sequence.
RING 1 RING 2 RING 3 RING 4	Ring commanded to flash
<b>Category 11, Automatic/Remote Flash</b>	
<b>AUTOMATIC FLASH</b>	
AUTO FLASH LOCAL INPUT	If IDOT CRC is indicated on the same line, then the automatic flash is caused by a detected IDOT CRC error. Ring 1-4 flash is shown for the Preemptor.
AUTO FLASH REMOTE INPUT	Flash triggered by Flash Remote input
PREEMPTOR COMMANDED FLASH	Flash triggered by the Preemptor input programmed in MM-4-1.
COORDINATOR PATTERN FLASH	Coordinator Pattern 255 commanded flash.
TIME BASE COMMANDED FLASH	A time-of-day program step is calling for flash. To disable flash, modify the time-of-day program step.
RING 1 RING 2 RING 3 RING 4	Ring commanded to flash by the coordinator pattern 255
<b>Category 12, FIO Card Failed Or Missing (2070)</b>	
<b>FIO CARD FAILED OR MISSING</b>	
<b>Category 13, DATABASE FIO TYPE MISMATCH (2070)</b>	
<b>DATABASE FIO TYPE MISMATCH</b>	

MM-7-7-1 Parameter	Description
Category 14, Unknown Flash Source	
<b>UNDEFINED FLASH SOURCE REPORTED</b>	

SDLC (Port 1) Status, MM-7-7-2

```

SDLC STATUS
MMU 128  DISABLED  TF  138  DISABLED
      129  DISABLED  TF  139  DISABLED
      131  DISABLED  TF  140  DISABLED
      141  DISABLED  TF  141  DISABLED
MMU STATUS:MMU DISABLED

DET 148  DISABLED  DET 152  DISABLED
      149  DISABLED  DET 153  DISABLED
      150  DISABLED  DET 154  DISABLED
      151  DISABLED  DET 155  DISABLED

TEST 158  DISABLED
    
```

**When in a hyperlink field:**

**To follow the hyperlink:**

For ASC/3, press **SPEC FUNC**, then **NEXT DATA**.

For 2070, press **B**.

**To go back:**

For ASC/3, press **SUB MENU**.

For 2070, press **ESC**.

MM-7-7-2 Parameter	Description
SDLC STATUS	<b>Note</b> • This is a hyperlink field, linked to MM-1-4-1, which configures Port 1 (SDLC).
MMU TF MMU STATUS DET TEST	<p>MMU = Malfunction Management Unit                      TF = Terminal and Facilities                      MMU STATUS = Shows what was programmed in MM-1-4-1, for ENABLE MMU EXTENDED STATUS.                      DET = Detector                      TEST = Diagnostics Frame</p> <p>The real-time status for each SDLC response frame:</p> <p><b>0-5:</b> There has been the indicated number of Response Frame Errors in the past 10 transmissions.</p> <p><b>6-10:</b> There has been the indicated number of Response Frame Errors in the past 10 transmissions. The SDLC command response is failed.</p> <p><b>DISABLED:</b> The Command is not enabled.</p>

- MMU Status, MM-7-7-3

### MMU Status, MM-7-7-3

EDI or RENO MMU														Other MMUs																			
MMU STATUS														MMU STATUS																			
MFG: EDI														MFG: .....																			
CHANNEL	1	2	3	4	5	6	7	8	9	0	1	2	3	4	5	6	CHANNEL	1	2	3	4	5	6	7	8	9	0	1	2	3	4	5	6
RED.....	.	.	.	.	.	.	.	.	.	.	.	.	.	.	.	.	RED.....	.	.	.	.	.	.	.	.	.	.	.	.	.	.	.	.
YELLOW..	.	.	.	.	.	.	.	.	.	.	.	.	.	.	.	.	YELLOW..	.	.	.	.	.	.	.	.	.	.	.	.	.	.	.	.
GREEN...	.	.	.	.	.	.	.	.	.	.	.	.	.	.	.	.	GREEN...	.	.	.	.	.	.	.	.	.	.	.	.	.	.	.	.
FAULT...	.	.	.	.	.	.	.	.	.	.	.	.	.	.	.	.	FAULT...	.	.	.	.	.	.	.	.	.	.	.	.	.	.	.	.
ENA-Y-CK	.	.	.	.	.	.	.	.	.	.	.	.	.	.	.	.	ENA-Y-CK	.	.	.	.	.	.	.	.	.	.	.	.	.	.	.	.
FAIL STATS	X	RLY	TRANFR	X	CONFLICT...	X	FAIL STATS	.	RLY	TRANFR	.	CONFLICT...	.																				
FIELD CHK	X	DUAL	IND	.	X	SPARE BIT 3	X	SPARE 1...	.	SPARE 2...	.	SPARE 3...	.																				
EXT WDOG..	X	Y+R	CLR...	X	SPARE BIT 6	X	SPARE 4...	.	SPARE 5...	.	SPARE 6...	.																					
PORT 1 FL.	X	RED	FAIL..	X	MIN CL	FAIL	X	PORT 1 FL.	.	RED	FAIL..	.	MIN CL	FAIL	.																		
CVM.....	X	MMU	DIAG..	X	STRUP	FL	CL	X	CVM.....	.	MMU	DIAG..	.	STRUP	FL	CL	.																
24V MON 1.	X	24V	MON 2.	X	24V	MON	INH	X	24V MON 1.	.	24V	MON 2.	.	24V	MON	INH	.																
MMU RESET.	X	RED	ENABLE	X	LOCAL	AU/FL	X	MMU RESET.	.	RED	ENABLE	.	LOCAL	AU/FL	.																		
FL TIME.	s	24V	LATCH.	X	CVM	LATCH..	X	FL TIME.	5s	24V	LATCH.	X	CVM	LATCH..	X																		

MM-7-7-3 Line(s)	Parameter—MMU Status	Description
1	MFG	Name of the manufacturer of the MMU.
3 thru 5	RED YELLOW GREEN	<p>This data shows a comparison of channel colors sent by the <i>ASC/3</i> controller (CU) and channel colors reported by the MMU. Each channel color may have one the following four values:</p> <p>“.” : The CU did not set a channel color and none was reported by the MMU.</p> <p><b>C</b>: The CU set this channel color, but it was not reported by the MMU.</p> <p><b>M</b>: The MMU reported this channel color, but it was <i>not</i> set by the CU.</p> <p><b>X</b>: The CU channel color matches the channel color reported by the MMU.</p>
6	FAULT	These are MMU detected-and-reported channel (not phase) faults. This information is a summary of all channel faults. The user must examine other information returned by the MMU to determine the exact fault source.

MM-7-7-3 Line(s)	Parameter—MMU Status	Description
7	ENA-Y-CK	<p><b>Enabled Yellow Check</b></p> <p>SDLC Response Frame 131, bits 129-144, returns an exact image of the Minimum Yellow Change Disable status programmed in the MMU. We have chosen to show the inversion of this channel data:</p> <p><b>X:</b> The feature is enabled.</p> <p><b>“.”</b> : The feature is disabled.</p>
8	FAIL STATS	<p>Type 129 Response Frame</p> <p>Immediate Response to Failure detected.</p>
8	RLY TRANFR	<p><b>X:</b> The Fail Output Relay of the MMU is closed.</p>
8	CONFLICT	<p><b>X:</b> The MMU senses two or more signals in conflict. Refer to more help on FIELD CHK bit (MM-7-7-3).</p>
9	SPARE 1 FIELD CHECK STATUS or FIELD CHECK FAULT	<p><b>X:</b> indicates the EDI or Reno A&amp;E MMU is reporting a Field Check Fault or Field Check Status.</p> <p>The MMU continuously checks to see if the colors received on its channel inputs match the colors in SDLC Command sent by the Controller Unit. These are Field Check Status bits that show the channel(s) on which the faulty colors were detected.</p> <p>The Field Check Status is reported with the Conflict, Red Fail, Clearance Fail, or Dual Indication monitoring functions of the MMU to produce additional diagnostic information about the detected fault. If a Conflict, Red Fail, Clearance Fail, or Dual Indication Fail occurs, the MMU will also identify the field inputs that did not match the Controller Unit output data (Spare Bit #1/FLDCHK FLT is set). This indicates that the cause of the Conflict, Red Fail, Clearance Fail, or Dual Indication malfunction was due to a problem in the load bay or field wiring or field loads on the reported channel(s).</p> <p>Note that if a Conflict, Red Fail, Clearance Fail, or Dual Indication fault is reported with NO Field Check Status (Spare Bit #1/FLDCHK FLT is clear), then the cause of the malfunction could be related to the Controller or MMU programming or both.</p>

## Status Displays

▪ MMU Status, MM-7-7-3

MM-7-7-3 Line(s)	Parameter—MMU Status	Description
9 <i>(cont.)</i>	SPARE 1 FIELD CHECK STATUS or FIELD CHECK FAULT	When a Field Check Fault occurs (Spare Bit #1/FLDCHK FLT is set, and no other fault bits are set) then the colors failed to match 10 consecutive times without causing a Conflict, Red Fail, Clearance Fail, or Dual Indication Fail. This is typically related to a Controller/MMU programming error or cabinet miswiring issue.  Refer to help text for FC/RED, FC/YELLOW, and FC/GREEN in MM-7-7-4. This information is returned in SDLC Response Frame 129, bit 67.
9	SPARE 2 DUAL INDICATOR	<b>X:</b> The EDI or Reno A&E MMU is reporting a Dual Indication Fault (multiple colors on the same channel).  This information is returned in SDLC Response Frame 129, bit 68. Refer to more help on FIELD CHK bit (MM-7-7-3).
9	SPARE 3 RECURRENT PULSE DETECTION	<b>X:</b> The EDI MMU is reporting a Recurrent Pulse Detection Status.  Refer to the help text for RP/RED, RP/YELLOW and RP/GREEN in MM-7-7-4. This information is returned in SDLC Response Frame 129, bit 69.
10	SPARE 4 EXTERNAL WATCHDOG FAULT.	<b>X:</b> The EDI or Reno A&E MMU is reporting the External Watchdog Fault.  This information is returned in SDLC Response Frame 129, bit 70.
10	SPARE 5 YELLOW/RED CLEARANCE FAULT	<b>X:</b> The EDI or Reno A&E MMU is reporting a Yellow/Red Clearance Fault (short yellow or short yellow/red).  This information is returned in SDLC Response Frame 129, bit 71. Refer to more help on FIELD CHK bit (MM-7-7-3).
10	SPARE 6	Currently not used. This information is returned in SDLC Response Frame 129, bit 72.
11	PORT 1 FL	Type 129 Response Frame. Port 1 Timeout Failure detected.
11	RED FAIL	<b>X:</b> One or more channels do not display a green or yellow or red as sensed by the MMU. Refer to more help on FIELD CHK bit (MM-7-7-3).
11	MIN CL FAIL	<b>X:</b> The minimum clearance between greens was less than 2.6 seconds, as sensed by the MMU.

MM-7-7-3 Line(s)	Parameter—MMU Status	Description
12	CVM	<b>X:</b> The MMU is reporting a Controller Voltage Monitor/Fault Monitor condition. This information is returned in SDLC Response Frame 129, bit 57.
12	MMU DIAG	<b>X:</b> The MMU is reporting an internal diagnostic failure. This information is returned in SDLC Response Frame 129, bit 73.
12	STRUP FL CL	<b>X:</b> The MMU is about to transfer the Output relay to the NO FAULT state. To allow the CU to revert to its out-of-flash state, the signal is generated for ½ second before the Output relay changes state. This information is returned in SDLC Response Frame 129, bit 80.
13	24V MON 1	<b>X:</b> +24 VDC Monitor Input 1 is less than +18 VDC, as measured by the MMU.
13	24V MON 2	<b>X:</b> The +24 VDC Monitor Input 2 is less than +18 VDC, as measured by the MMU.
13	24V MON INH	<b>X:</b> The +24 VDC Monitor Inhibit input to the MMU is active.
14	MMU RESET	<b>X:</b> The reset input to the MMU is active.
14	RED ENABLE	<b>X:</b> The red enable input to the MMU is active.
14	LOCAL AU/FL	<b>X:</b> The MMU's local/cabinet flash input is TRUE. This information is returned in SDLC Response Frame 129, bit 79.  <b>Note • This NEMA label is misleading because the status has nothing to do with Automatic Flash.</b>
15	FL TIME	<b>X:</b> The value, in seconds, of the MMU Flash Time (6-16 seconds) programmed in the MMU. This information is returned in SDLC Response Frame 131, bits 145-148.
15	24V LATCH	<b>X:</b> This row shows +24 Volt Latch programming in the MMU.
15	CVM LATCH	This is the status of the CVM/Fault Monitor latch option that is programmed in the MMU.  <b>X:</b> The MMU is programmed to latch these failure conditions. This information is returned in SDLC Response Frame 131, bit 150.

## Status Displays

- MMU Extended Status, MM-7-7-4

### MMU Extended Status, MM-7-7-4

```

MMU EXT STATUS          MFG: ...
CHANNEL  1 2 3 4 5 6 7 8 9 0 1 2 3 4 5 6
FC/RED.. . . . . . . . . . . . . . . . .
FC/YEL.. . . . . . . . . . . . . . . . .
FC/GREEN . . . . . . . . . . . . . . . .
RP/RED.. . . . . . . . . . . . . . . . .
RP/YEL.. . . . . . . . . . . . . . . . .
RP/GREEN . . . . . . . . . . . . . . . .
RY GON.. . . . . . . . . . . . . . . . .
FAULT... . . . . . . . . . . . . . . . .
LAST FAULT REPORT: 00:00:00 00/00/00
NO FAULT
  
```

If this feature is disabled, the display below will come into view.

```

MMU EXT STATUS
EXTENDED MMU STATUS DISPLAY IS DISABLED.
AND/OR MMU IS DISABLED.
GO TO MM-1-4-1 TO ENABLE IF MMU IS
COMPATIBLE WITH THIS FEATURE.

SUPPORTED MMU FOR EXTENDED MMU STATUS:

                ECONOLITE
                EDI
                RENO A&E
  
```

MM-7-7-4 Parameter	Description
MFG	Name of the manufacturer of the MMU.
FC/RED FC/YEL FC/GREEN	These are Field Check Faults. The MMU continuously checks to see if the colors received on its channel inputs match the colors in SDLC Command Frame 0 (the commanded CU channel colors). If the colors fail to match 10 consecutive times, the MMU generates a Field Check Fault and transfers the Output relay to the fault position. This data shows the channel(s) on which the fault was detected.
RP/RED RP/YEL RP/GREEN	This is a proprietary feature of the EDI MMU. These are <b>Recurrent Pulse</b> Faults reported only by the EDI MMU. There are cases where signals monitored for faults are pulsing or of an intermittent nature and are short enough not to meet the triggering timing condition defined by the NEMA TS2 standard. Basically, this feature generates a fault if these recurring fault conditions are detected over a longer time interval, but are too short to meet NEMA timing requirements.  For more information, refer to the EDI MMU operations manual.



MM-7-7-4 Parameter	Description
RY GON	<p>These faults are reported only by the EDI MMUs. The Red + Yellow Gon Status indicates the channel(s) that caused the MMU to detect a Minimum Yellow Plus Red Clearance fault (TS2 clause 4.4.5.1). Fault Status will report the channels that the Yellow Plus Red Clearance fault occurred on (channel terminating). The Red + Yellow Gon Status report the channels that caused the clearance fault (channel going active/Green).</p> <p>For all other fault types the Red + Yellow Gon Status is not relevant and will be zero.</p> <p><b>Example:</b> If phase 2 Walk (channel 13) terminates, and phase 8 Green (channel 8) goes active in less than 2.8 seconds, the fault status bytes for this Minimum Yellow Plus Red Clearance fault will indicate channel 13, and the Red + Yellow Gon Status will indicate channel 8.</p>
FAULT	<p>These are MMU detected and reported channel (not phase) faults. This information is a summary of all channel faults. The user must examine other information returned by the MMU to determine the exact fault source.</p>
LAST FAULT REPORT	<p>There are two items associated with this input::</p> <ul style="list-style-type: none"> <li>■ Time-of-day and date. This value shows current time and date as long as there is no MMU detected fault. If the MMU is reporting a fault, the time and date will report the exact time and date the fault occurred.</li> <li>■ There is a message below the time and date line that describes the fault. Possible messages:</li> </ul> <p>NO FAULT, CVM, 24V MON 1, 24VMON 2, CVM AND 24V MON 1, CVM AND 24V MON 2, 24V MON 1 AND 2, CVM, 24V MON 1 AND 2, EXTERNAL WATCHDOG, PROGRAM CARD, CONFLICT, RED FAIL, SHORT YELLOW, SKIPPED YELLOW, SHORT RED+YELLOW, PORT 1 FAULT, MMU DIAGNOSTIC, DUAL INDICATION, FIELD CHECK, TYPE FAULT, LOCAL FLASH, CONFIGURATION CHANGE, BROWNOUT, RECURRENT PULSE CONFLICT, RECURRENT PULSE RED FAIL, RECURRENT PULSE DUAL INDICATION, UNKNOWN FAULT</p>

**Status Displays**

- MMU AC Status, MM-7-7-5

**MMU AC Status, MM-7-7-5**

```

MMU AC STATUS                MFG: ...
NO FAULT
AC LINE:  0 VRMS AT N/A  HZ,TEMP: -40 F
RED ENABLE:  0 VRMS
CHANNEL:  01  02  03  04  05  06  07  08
  RED:    0   0   0   0   0   0   0   0
  YEL:    0   0   0   0   0   0   0   0
  GRN:    0   0   0   0   0   0   0   0
CHANNEL:  09  10  11  12  13  14  15  16
  RED:    0   0   0   0   0   0   0   0
  YEL:    0   0   0   0   0   0   0   0
  GRN:    0   0   0   0   0   0   0   0

LAST FAULT REPORT: 00/00/00 00:00:00
    
```

If this feature is disabled, the display below will come into view.

```

MMU AC STATUS REPORT
EXTENDED MMU STATUS DISPLAY IS DISABLED.
AND/OR MMU IS DISABLED.
GO TO MM-1-4-1 TO ENABLE IF MMU IS
COMPATIBLE WITH THIS FEATURE.

SUPPORTED MMU FOR EXTENDED MMU STATUS:

        ECONOLITE
        EDI
        RENO A&E
    
```

<b>MM-7-7-5 Parameter</b>	<b>Description</b>
MFG	Name of the manufacturer of the MMU.
NO FAULT, etc.	This line describes the fault. Possible messages: NO FAULT, CVM, 24V MON 1, 24V MON 2, CVM AND 24V MON 1, CVM AND 24V MON 2, 24V MON 1 AND 2, CVM, 24V MON 1 AND 2, EXTERNAL WATCHDOG, PROGRAM CARD, CONFLICT, RED FAIL, SHORT YELLOW, SKIPPED YELLOW, SHORT RED+YELLOW, PORT 1 FAULT, MMU DIAGNOSTIC, DUAL INDICATION, FIELD CHECK, TYPE FAULT, LOCAL FLASH, CONFIGURATION CHANGE, BROWNOUT, RECURRENT PULSE CONFLICT, RECURRENT PULSE RED FAIL, RECURRENT PULSE DUAL INDICATION, UNKNOWN FAULT

MM-7-7-5 Parameter	Description
AC LINE	This is the AC line RMS voltage. The information is returned by Reno A&E (SDLC Response Frame 192) or EDI MMU (SDLC Response Frame 202).
VRMS AT ____ HZ	This is the AC line frequency in Hertz with a resolution of 0.1 Hz (for example, 60.2 Hz). The information is returned by Reno A&E (SDLC Response Frame 192) or EDI MMU (SDLC Response Frame 202).
TEMP, °F	This is the cabinet temperature in degrees Fahrenheit (-40 to 214), where N/A indicates data is not available. The information is returned by Reno A&E (SDLC Response Frame 192) or EDI MMU (SDLC Response Frame 202).
RED ENABLE, VRMS	This is the RMS voltage value of the RED ENABLE input to the MMU. The information is returned by Reno A&E SDLC Response Frame 192 or EDI SDLC Response Frame 202.
RED YEL GRN	RED (01-08), YELLOW (01-08), GREEN (01-08), RED (09-16), YELLOW (09-16), GREEN (09-16) These are the AC RMS voltages on each channel color input. The information is returned by Reno A&E (SDLC Response Frame 192) or EDI MMU (SDLC Response Frame 202).
LAST FAULT REPORT	Time-of-day and date. This value shows current time and date as long as there is no MMU detected fault. If the MMU is reporting a fault, the time and date will report the exact time and date the fault occurred.

- MMU Compatibility Status, MM-7-7-6, ECPI Feature

### MMU Compatibility Status, MM-7-7-6, ECPI Feature

```

MMU COMPATIBILITY STATUS MFG:
CH|6 5 4|3 2 1|0 9 8|7 6 5|4 3 2
1 . . . . . X . . . . X X . . .
2 . . . . . X . X . C X X . . .
3 . . . . . X . . . . X X . . .
4 . . . M X . X . X X . . .
5 . . . . . . . X . . .
6 . . . . . X . X . . .
7 . . . . . . X . . .
8 . . . . X . X . .
9 . . . . . X . .
10 . . . . X . .
11 . . . . .
12 . . . . .
13 . . . .
14 . . .
15 . . .
    
```

This display shows the real time comparison between the controller INTERNAL Compatibility (MM-1-4-2) and the MMU programming card, as reported by SDLC communications.

“.” : Neither the Controller Unit (CU) or the MMU is programmed.

**C:** The CU is programmed but the MMU is not.

**M:** The MMU is programmed but the CU is not.

**X:** Both the CU and the MMU are programmed.

## Input/Output Status Submenu, MM-7-8

```

INPUT / OUTPUT SUBMENU

1.CONTROLLER INPUTS   6.T&f BIU I/O
2.CONTROLLER OUTPUTS  7.D/R BIU I/O
3.HARDWARE INPUTS     8.RESERVED
4.HARDWARE OUTPUTS    9.I/O DIFFERENCES
5.AUX HARDWARE I/O
    
```

### Controller Inputs, MM-7-8-1

These displays show the real-time status of the inputs for NEMA functions or 332 layout inputs:

NEMA Functional Inputs	332 Layout Inputs
<pre> INPUTS FUNCTIONS   PHASE  1   2   3   4   5   6   7   8 VEH DET.. . . . . . . . . PED DET.. . . . . . . . . VEH OMIT.. . . . . . . . . PED OMIT.. . . . . . . . . HOLD..... . . . . . . . .  INPUTS--   RG 1 RG 2 FORCE OFF... . . . . INHIBIT MAX. . . . . MAX II..... . . . . OMIT RED CL. . . . . PED RECYCLE. . . . . RED REST.... . . . . STOP TIME... . . . .  INPUTS-- PREEMPT..... 2-. 4-. 5-. 6-. IO MODE SELECT. A-. B-. C-. TEST INPUT.... A-. B-. C-. CALL NON ACT... 1-. 2-. COORD/FREE. .   EXT START. .   MINRECALL. . LAMP OFF... .   INTER ADV. .   MCE..... . WLK RST MOD .                       </pre>	<pre> C1/C11 INPUT FUNCTIONS I INPUT FILE S#01 02 03 04 05 06 07 08 09 11 12 13 14 P#56 39 63 47 58 41 65 49 60 80 67 68 81 F: . . . . . . . . . . . . . . . P#-- 43 76 -- -- 45 78 -- 62 53 69 70 82 W: . . . . . . . . . . . . . . .  J INPUT FILE S#01 02 03 04 05 06 07 08 09 11 12 13 14 P#55 40 64 48 57 42 66 50 59 54 71 72 51 F: . . . . . . . . . . . . . . . P#-- 44 77 -- -- 46 79 -- 61 75 73 74 52 W: . . . . . . . . . . . . . . .  2A MODULE C11S INPUTS PIN# 10 11 12 13 15 16 17 18 19 FUNC: . . . . . . . . . . . . . . . PIN# 20 21 22 23 24 25 26 27 28 29 30 FUNC: . . . . . . . . . . . . . . .                     </pre>

▪ Controller Outputs, MM-7-8-2

**I/O Status Indicator:**

- ▶ **X**: Active
- ▶ “.”: Inactive
- ▶ \* : NOT Used

The beeper is normally disabled. When the data that the cursor is under changes, the beeper will sound for 1/10 second, regardless of the programming in MM-1-7-2.

**Controller Outputs, MM-7-8-2**

These displays show the real time status of the outputs for NEMA or 332 functional outputs.

NEMA Functional Outputs	332 Functional Outputs
<pre> OUTPUT FUNCTIONS   PHASE 1  2  3  4  5  6  7  8 RED..... . . . . . . . . YELLOW... . . . . . . . . GREEN.... . . . . . . . . DONT WALK . . . . . . . . PED CLEAR . . . . . . . . WALK..... . . . . . . . . PH CHECK. . . . . . . . . PH NEXT... . . . . . . . . PHASE ON. . . . . . . . . OVLP A  B  C  D   RING 1  2   SPEC RED . . . . .  STAT A . .  CVM . YEL . . . . .  STAT B . .  FM . GRN . . . . .  STAT C . .  FL .                     </pre>	<pre> C1/C11 OUTPUT FUNCTIONS PH: V1 V2 P2 V3 V4 P4 V5 V6 P6 V7 V8 P8 PIN# 16 12 10 07 04 02 32 29 27 24 21 19 RED: . . . . . . . . . . . . . . PIN# 17 13 35 08 05 37 33 30 36 25 22 38 YEL: . . . . . . . . . . . . . . PIN# 18 15 11 09 06 03 34 31 28 26 23 20 GRN: . . . . . . . . . . . . . . 2A MODULE C1 OUTPUTS OL: A B C D TBC FUNCTION SPARE PIN# 97 94 88 85 83 101 91 RED: . . . . SF1 . CABFLASH . SP - PIN# 98 95 89 86 100 102 93 YEL: . . . . SF2 . DETRESET . SP . PIN# 99 96 90 87 84 103 GRN: . . . . SF3 . WATCHDOG . 2A MODULE C11S OUTPUTS PIN# 01 02 03 04 05 06 07 08 . . . . . . . .                     </pre>

**I/O Status Indicator:**

- ▶ **X**: Active
- ▶ “.”: Inactive
- ▶ \* : NOT Used

The beeper is normally disabled. When the data that the cursor is under changes, the beeper will sound for 1/10 second, regardless of the programming in MM-1-7-2.

### Hardware Inputs, MM-7-8-3

These displays show the real time status of the inputs for the NEMA ABC or the 332 C1/C11 physical inputs:

NEMA A, B,C Inputs	332 C1 & C11 Inputs
<pre> ABC INPUTS CONNECTOR MS-A  K L M N P R S T f g h   INPUTS        . . . . . CONNECTOR MS-A  i j k m n q v w x y z   INPUTS        . . . . . CONNECTOR MS-A  AA BB EE FF GG HH   INPUTS        . . . . . CONNECTOR MS-B  B L M N P R S T U V W X   INPUTS        . . . . . CONNECTOR MS-B  g h i j k m n v x y z   INPUTS        . . . . . CONNECTOR MS-C  P R S T U V W X Y Z a b   INPUTS        . . . . . CONNECTOR MS-C  m n p q r s t u v EE   INPUTS        . . . . .                     </pre>	<pre> C1/C11 INPUTS CONNECTOR          PIN C1-Input   39 40 41 42 43 44 45 46 47 48             . . . . . C1-Input   49 50 51 52 53 54 55 56 57 58             . . . . . C1-Input   59 60 61 62 63 64 65 66 67 68             . . . . . C1-Input   69 70 71 72 73 74 75 76 77 78             . . . . . C1-Input   79 80 81 82             . . . . . C11-Input  10 11 12 13 15 16 17 18 19 20             . . . . . C11-Input  21 22 23 24 25 26 27 28 29 30             . . . . . INPUTS                     </pre> <p style="text-align: center;">ASC3 1000/2070 2N MODULE</p> <p style="text-align: center;">There are no HARDWARE inputs for this Controller. To view I/O on this Controller, check T&amp;F or D/R I/O.</p>

**I/O Status Indicator:**

- ▶ X: Active
- ▶ “.”: Inactive
- ▶ \*: NOT Used

The beeper is normally disabled. When the data that the cursor is under changes, the beeper will sound for 1/10 second, regardless of the programming in MM-1-7-2.





### Auxiliary Hardware I/O, MM-7-8-5

These displays show the real time status of the outputs for the Auxiliary Hardware I/O:

NEMA Auxiliary Hardware I/O	332 Auxiliary Hardware I/O
D I/O	D I/O
01 02 03 04 05 06 07 08 09 10 11 12 13 O O I I O I * 0 I I O I I	A B C D E F G H J K L M N P R S T U V W I I I I I I I I I I I I I I I I I I
14 15 16 17 18 19 20 21 22 23 24 25 26 I O I I I I I O O O O I I	X Y Z a b c d e f g h i j k m n p q r s I I I I I I I I I I I I I I I I I I
27 28 29 30 31 32 33 34 35 36 37 38 39 O O O I I O O O I I I I I	t u v w x y z AA BB CC DD EE FF GG HH JJ I I I I I I O O O O O O O O O O
40 41 42 43 44 45 46 47 48 49 50 51 52 I O O O O O O I O I I O O	KK LL MM NN PP * O * * *
53 54 55 56 57 58 59 60 61 O O I I I I O I I	
TLM I/O TELEMETRY	
01 02 03 04 05 06 07 08 09 10 11 12 13 I I I I I I I I I O O * * *	
14 15 16 17 18 19 20 21 22 23 24 25 I I I I I I I I O O * *	

**I/O Status Indicator:**

- ▶ I or O: Active
- ▶ “.”: Inactive
- ▶ \*: NOT Used

- T&F BIU I/O, MM-7-8-6

### T&F BIU I/O, MM-7-8-6

This display shows the real time status of the outputs for the T&F BIU I/O Status:

T&F BIU I/O		I/O Function							
BIU # 1		1	2	3	4	5	6	7	8
TF- OUT		.	.	.	.	.	.	.	.
OUT		9	10	11	12	13	14	15	
		.	.	.	.	.	.	.	.
TF- I/O		01	02	03	04	05	06	07	08
		IO	IO	IO	IO	IO	IO	IO	IO
I/O		09	10	11	12	13	14	15	16
		IO	IO	IO	IO	IO	IO	IO	IO
I/O		17	18	19	20	21	22	23	24
		IO	IO	IO	IO	IO	IO	IO	IO
TF- IN		1	2	3	4	5	6	7	8
		.	.	.	.	.	.	.	.
TF- OPTO		1	2	3	4				
		.	.	.	.				

**I/O Status Indicator:**

- ▶ **O**: Active Output
- ▶ **I**: Active Input
- ▶ **“.”**: Inactive Input or Output

### D&R BIU I/O, MM-7-8-7

This display shows the real time status of the outputs for the D/R BIU I/O Status.

D/R BIU I/O		I/O Function							
BIU # 1		1	2	3	4	5	6	7	8
DR- DETECTOR		.	.	.	.	.	.	.	.
DETECTOR		9	10	11	12	13	14	15	16
		.	.	.	.	.	.	.	.

**I/O Status Indicator:**

- ▶ **O**: Active Output
- ▶ **I**: Active Input
- ▶ **“.”**: Inactive Input or Output

## I/O Differences Status, MM-7-8-9, ECPI Feature

### Example Display

```

M CNR/PIN  DEFAULT DB      ACTIVE DB
0 A/o-F    PHASE 02 RED     PHASE 04 RED
0 A/o-d    PHASE 02 CHK     PHASE 10 RED
0 A/i-h    PHASE 01 HOLD   PHASE 10 HOLD
0 B/o-E    PHASE 03 YEL     PHASE 04 YEL
0 C/o-C    PHASE 08 DWK     PHASE 06 DWK
TF1/o-18B DIMMING ENABLE  TLM SPC FUNC 2
TF1/o-02B LOADSW 09 YEL   PHASE 01 GRN
TF1/x-21A NOT ASSIGN     OVERLP I GRN
0 T/i-16  MAINTENANCE REQ  PHASE 10 OMIT
- C01o103
- C11o07

```

For definitions of abbreviations used in connector pin functions, Refer to *Abbreviations in Connector Pin Functions* on page T-14 .

This display shows the I/O mapping differences between the Default DB and the Active DB.

**M:** I/O Mode, only applicable to TS 1 and TS 2 type cabinet.

**CNR/PIN:** Connector/Pin

Lower case o is for output

Lower case i is for input

Lower case x is either input or output

**DEFAULT DB:** Signal assignment on the Econolite Default DB

**ACTIVE DB:** Signal assignment on the active DB

---

**Note** • ASC/3 Configurator can be used to remap the pin and the function.

---

---

**For your notes:**

## Utilities

### Utilities Submenu, MM-8

UTILITIES SUBMENU	
1. COPY / CLEAR	5. SIGN ON
2. USB MANAGEMENT	6. LOG BUFFERS
3. PRINT	7. SOFTWARE MODULES
4. TRANSFER	

### Programming Summary

A brief description follows of the programming functions that you can see and/or change at each of the menu options.

MM-8 Menu Option	Programming Summary
1. COPY / CLEAR	You can copy or clear back to default 13 different data groups: Phase Data, Timing Plan Data, Phase Detector Options Plan Data, Detector Plan Data, Coordinator Pattern Data, Split Pattern Data, Sequence Data, Datakey Data, Controller Data, Default Database, Econolite Database, MMU Program Card Data, and Special Features Data.
2. USB MANAGEMENT	Work with files on a USB flash drive plugged into the USB port of a 2070-1C CPU module installed in a 2070 controller.
3. PRINT	Select either Port 2/C50S or Port 3A/C21S as the print port and enable (X) or disable (.) nine different options to print.

- Copy/Clear Utility, MM-8-1

MM-8 Menu Option	Programming Summary
4. TRANSFER	Transfer data between eight different areas: Data Module, Data Flash, Port, I/O Mapping, Logic Processor, and Access codes.  <b>To transfer:</b> <b>1</b> Select one FROM and one TO. <b>2</b> To transfer, press <b>ENTER</b> (for 2070, press <b>ENT</b> )
5. SIGN ON	In the System Sign-On screen, you can edit the text in two lines: the line with “Solutions that Move the World” and the line that follows.
6. LOG BUFFERS	Display, Print, or Clear the log buffers for Controller Events, Detector Events, Detector Activity, MMU Events, or Select All.
7. SOFTWARE MODULES	This displays the name, part number, and revision level for all installed software modules. This information can be seen and/or edited, as applicable.

### Copy/Clear Utility, MM-8-1

```

COPY / CLEAR UTILITY
      FROM      >      TO
PHASE TIMING.... . > PHASE TIMING.... .
TIMING PLAN..... . > TIMING PLAN..... .
PH DET OPT PLAN. . > PH DET OPT PLAN. .
DETECTOR PLAN... . > DETECTOR PLAN... .
COORD PATTERN... . > COORD PATTERN... .
SPLIT PATTERN... . > SPLIT PATTERN... .
SEQUENCE..... . > SEQUENCE..... .
ACTION PLAN..... . > ACTION PLAN..... .
PREEMPT PLAN.... . > PREEMPT PLAN.... .
LP STATEMENT.... . > LP STATEMENT.... .
DATA KEY..... . > CONTROLLER DATA. .
CONTROLLER DATA. . > DATA KEY..... .
DEFAULT DATABASE . > CONTROLLER DATA. .
ECONOLITE DBASE . > CONTROLLER DATA. .
CONTROLLER DATA. . > DEFAULT DATABASE .
MMU PROGRAM..... . > CONTROLLER..... .
SPECIAL FEATURES . > CONTROLLER..... .

      TOGGLE TO SELECT A "FROM" AND A "TO"
      THEN PRES ENTER
    
```

Use this screen to copy 13 different data groups as described in the paragraphs that follow. As shown, this screen has two columns (labeled FROM and TO).

**To make a copy:**

- 1** Move the cursor to the applicable row.
- 2** Enter applicable data in the FROM and TO data entry fields (for instructions, refer to the paragraphs that follow).
- 3** To make a copy, press **ENTER** (for 2070, press **ENT**).

**Note** • As you read through the table that follows, observe the notes below:

- If the data entry in the TO column is non-zero, the data in the FROM column copies to the one related destination in the TO column. However, if you can enter **0** (zero) in a TO column data entry field, the zero causes the related FROM field to copy its data to *all* the possible recipients in the TO field.
- If the data entry in the FROM column is a zero, default data will be copied to the specified destination in the TO column.

MM-8-1 Parameter	Description	Range
PHASE TIMING	<p><b>Copy Phase/Timing Data (MM-2-1)</b></p> <p>When you press <b>ENTER</b>, copies all data from the specified FROM column Phase number (1-16) and Timing Plan number (1-4) to the specified TO column Phase number (0-16) and Timing Plan number (0-4).</p> <p>For a <b>0</b> (zero) entry in the TO or FROM column, refer to the Note before this table.</p>	<p>FROM column: (0-16) (0-4)</p> <p>TO column: (0-16) (0-4)</p>
TIMING PLAN	<p><b>Copy Timing Plan Data (MM-2-1)</b></p> <p>When you press <b>ENTER</b>, copies all data from the specified FROM column Timing Plan number (1-4) to the specified TO column Timing Plan number (0-4).</p> <p>For a <b>0</b> (zero) entry in the TO or FROM column, refer to the Note before this table.</p>	<p>FROM column: (0-4)</p> <p>TO column: (0-4)</p>
PH DET OPT PLAN	<p><b>Copy Phase Detector Options Plan Data (MM-6-3)</b></p> <p>When you press <b>ENTER</b>, copies all phase level detector locking-recall, No Rest, and Added Initial data from the specified FROM column Phase Detector Option Plan (1-4) to the specified TO column Phase Detector Option Plan (0-4).</p> <p>For a <b>0</b> (zero) entry in the TO column, refer to the Note before this table.</p>	<p>FROM column: (0-4)</p> <p>TO column: (0-4)</p>

- Copy/Clear Utility, MM-8-1

MM-8-1 Parameter	Description	Range
DETECTOR PLAN	<p><b>Copy Detector Plan Data (MM-6-2)</b></p> <p>When you press <b>ENTER</b>, copies all data from the specified FROM column Vehicle Detector Plan number (1-4) to the specified TO column Vehicle Detector Plan number (0-4).</p> <p>For a <b>0</b> (zero) entry in the TO or FROM column, refer to the Note before this table.</p>	<p>FROM column: (0-4)</p> <p>TO column: (0-4)</p>
SPLIT PATTERN	<p><b>Copy Split Pattern Data (MM-3-3).</b></p> <p>When you press <b>ENTER</b>, copies all data from the specified FROM column Split Pattern number (1-120) to the specified TO column Split Pattern number (0-120).</p> <p>For a <b>0</b> (zero) entry in the TO or FROM column, refer to the Note before this table.</p>	<p>FROM column: (0-120)</p> <p>TO column: (0-120)</p>
COORD PATTERN	<p><b>Copy Coordination Pattern Data (MM-3-2).</b></p> <p>When you press <b>ENTER</b>, copies all data from the specified FROM column Coordination Pattern number (1-120) to the specified TO column Coordination Pattern number (0-120).</p> <p>For a <b>0</b> (zero) entry in the TO or FROM column, refer to the Note before this table.</p>	<p>FROM column: (0-120)</p> <p>TO column: (0-120)</p>
SEQUENCE	<p><b>Copy Sequence Data (MM-1-1-1)</b></p> <p>When you press <b>ENTER</b>, copies all data from the specified FROM column Sequence Pattern number (1-16) to the specified TO column Sequence Pattern number (0-16).</p> <p><b>Exception:</b> Entry is ignored if you enter sequence 1 or the sequence in effect.</p> <p>For a <b>0</b> (zero) entry in the TO or FROM column, refer to the Note before this table.</p>	<p>FROM column: (0-16)</p> <p>TO column: (0-16)</p>
ACTION PLAN	<p><b>Copy Action Plan Data (MM-5-2)</b></p> <p>When you press <b>ENTER</b>, copies all data from the specified FROM column Action Plan number to the specified TO column.</p> <p>For a <b>0</b> (zero) entry in the TO or FROM column, refer to the Note before this table.</p>	<p>FROM column: (0-100)</p> <p>TO column: (0-100)</p>



MM-8-1 Parameter	Description	Range
PREEMPT PLAN	<p><b>Copy Preempt Plan Data (MM-4-1)</b></p> <p>When you press <b>ENTER</b>, copies all data from the specified FROM column Preempt Plan number to the specified TO column.</p> <p>For a <b>0</b> (zero) entry in the TO or FROM column, refer to the Note before this table.</p>	<p>FROM column: (0-10)</p> <p>TO column: (0-10)</p>
LP STATEMENT	<p><b>Copy LP Statement (MM-1-8-2)</b></p> <p>When you press <b>ENTER</b>, copies all data from the specified FROM column LP Statement number to the specified TO column.</p> <p>For a <b>0</b> (zero) entry in the TO or FROM column, refer to the Note before this table.</p>	<p>FROM column: (0-100)</p> <p>TO column: (0-100)</p>
DATA KEY to CONTROLLER DATA	<p><b>Copy Datakey Data to Controller</b></p> <p>When you press <b>ENTER</b>, copies all Datakey data to the Controller when both the FROM and TO columns are enabled with an "X". "." in either column disables the Copy function.</p>	<p>X enables "." disables</p>
CONTROLLER DATA to DATA KEY	<p><b>Copy Controller Data to Datakey</b></p> <p>When you press <b>ENTER</b>, copies all Controller data to the Datakey when both the FROM and TO columns are enabled with an "X". "." in either column disables the Copy function.</p>	<p>X enables "." disables</p>
DEFAULT DATABASE to CONTROLLER DATA	<p><b>Copy Default Database to Controller</b></p> <p>When you press <b>ENTER</b>, copies the Default Database to the Controller when both the FROM and TO columns are enabled with an "X". "." in either column disables the Copy function.</p> <p><b>Note</b> • Requires supervisor access code to be set.</p> <p><b>Note</b> • To work, this requires an existing Default Database. To create Default Database, refer to MM-8-1, <i>Copy Controller Database to Default Database</i> on page 13-6.</p>	<p>FROM column: X, "."</p> <p>TO column: X, "."</p>
ECONOLITE DATABASE to CONTROLLER DATA	<p>Lets you copy Econolite default data to the controller. You must enable both COPY FROM and TO with an X.</p>	<p>X enables "." disables</p>

- Copy/Clear Utility, MM-8-1

MM-8-1 Parameter	Description	Range
CONTROLLER DATA to DEFAULT DATABASE	<p><b>Copy Controller Database to Default Database</b></p> <p><b>Note</b> • Requires supervisor access code to be set.</p> <p>When you press <b>ENTER</b>, copies the Controller Database to the Default Database when both the FROM and TO columns are enabled with an “X”. “.” in either column disables the Copy function.</p>	<p>FROM column: X, “.”</p> <p>TO column: X, “.”</p>
MMU PROGRAM	<p><b>MMU Program Card Copy</b></p> <p>ECPI Feature</p> <p>Requires that the supervisor's access code be set.</p> <p>TOGGLE to select (X) or deselect (.) to copy the MMU Program Card to the MMU PROGRAM entries.</p> <p><b>X</b>: Copies the MMU PROGRAM CARD data that is received in response frame 131 to the <i>ASC/3</i> MM-1-4-2 programming. The display will return to the default state (.) after copying.</p> <p>This copy makes the controller programming identical to this MMU’s compatibility programming.</p> <p>“.”: Does not copy the MMU Program Card data.</p>	<p>X, “.”</p>

MM-8-1 Parameter	Description	Range
SPECIAL FEATURES	<p>Enable a Special Feature(s)</p> <p>ECPI Feature</p> <p>To enable a Special Feature in an <i>ASC/3</i> controller, use this procedure:</p> <ol style="list-style-type: none"> <li><b>1</b> Get a blue Datakey® with the Special Feature enabled. TSP (Datakey Part No. SFDT1000000000) and ACS Lite adaptive control (Datakey Part No. SFDT0010000000) are possible Special Features.</li> <li><b>2</b> Power up the <i>ASC/3</i>.</li> <li><b>3</b> Insert the blue Datakey into the DATAKEY slot.</li> <li><b>4</b> In this screen, (MM-8-1), toggle to select (X) SPECIAL FEATURES.</li> <li><b>5</b> Move the cursor to the right to CONTROLLER and toggle to select (X).</li> <li><b>6</b> Press <b>ENTER</b> to enable the programmed Special Features.</li> <li><b>7</b> When processing is completed, a message will be displayed to indicate the special features that have been enabled.</li> <li><b>8</b> To keep the Special Feature enabled, keep the blue Datakey inserted in its slot. If you remove the blue Datakey, the <i>ASC/3</i> will disable the Special Feature at midnight.</li> </ol> <p><b>Note</b> • After you use a black Datakey to copy the controller database, it is OK to remove the Datakey. You do not need to keep the black Datakey in its slot to keep the database settings.</p>	X, “.”

- USB Management, MM-8-2

## USB Management, MM-8-2

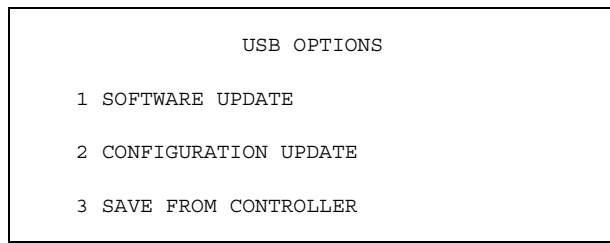

---

**Note** • This USB Management screen is only for a 2070 with (1) a 2070-1C CPU module and (2) ASC/3-LX software Version 32.55.00 or later. You must plug in a USB flash drive (formatted for FAT 16/32) into the USB port of the 2070-1C CPU.

---

### To manage your data files with a USB flash drive:

- 1 Copy the files you want to manage to the root directory of a USB flash drive (formatted for FAT16/32). For example, to upgrade the software, you typically copy seven files.
- 2 Press **A** and go to the Main Menu.
- 3 At the rear of your 2070, in the top left corner of the 2070-1C CPU module, plug the USB flash drive into the USB port:

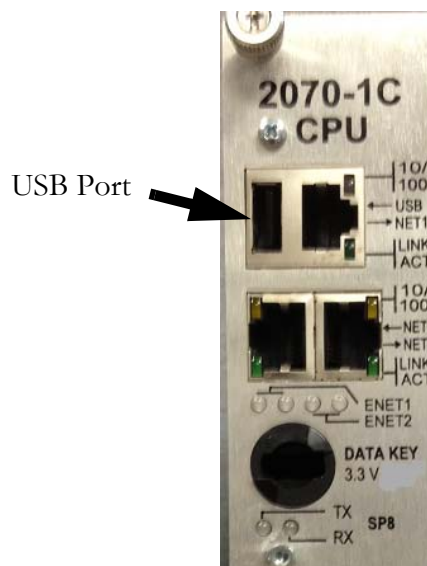

- 4 After a few seconds, screen MM-8-2 (shown above) opens automatically.
- 5 Select what you want to do and the screens that follow will prompt you as necessary.
- 6 The sub-menu screens are shown in [Appendix B](#) on [page B-36](#).

---

**Note** • To complete a software installation: (1) remove the USB flash drive and (2) wait at least 5 minutes, then recycle the controller to activate the new software. After you complete your DB management, always immediately remove the USB flash drive.

---

## File Name Syntax

A typical configuration (CFG) file is of the form `DB_XX.XX.XX.XX_YYMMDD_HHMMSS.CFG` where:

`XX.XX.XX.XX` is the IP address of the controller  
`yy` are the last two digits of the year  
`MM` is the month of the year  
`DD` is the day of the month  
`HH` is the hour in military (24 hour) time  
`MM` are the minutes  
`SS` are the seconds

Thus, for the example `DB_10.70.10.51_130225_174233.CFG` :

This is a current database file where `10.70.10.51` is the IP address of the controller and this file was saved in the year 2013 on February 25 at 5:42 pm and 33 seconds.

## Print Utility, MM-8-3

```

PRINT

PRINT TO PORT... 2
                        SELECT ALL..... .

CONFIGURATION... . TIME BASE..... .

CONTROLLER..... . DETECTOR..... .

COORDINATOR..... . LOGIC PROCESSOR. .

PREEMPTOR..... . TSP AND SCP..... .

TOGGLE TO SELECT AND THEN PRESS ENTER
TO BEGIN PRINTING

```

### To print information to a port:

- 1 Press toggle **0/YES** to select the print output port, Port 2/C50S, Port 3A/C21S or USB.

---

**Note** • USB is only for a 2070 with a 2070-1C CPU module. You must plug in a USB flash drive (formatted for FAT 16/32) into the USB port of the 2070-1C CPU. When you select USB, the controller prints the selected database configurations to the text file, `DB_XX.XX.XX.XX_YYMMDD_HHMMSS.TXT`, in the USB flash drive.

---

- 2 As applicable, press toggle **0/YES** to Enable (X) or Disable (.) the nine possible fields to print.

### To print the enabled field(s) to the selected port:

- ▶ Press **ENTER./ENT**

- Transfer Utility, MM-8-4

### Transfer Utility, MM-8-4

```
TRANSFER UTILITY

      PORT..... 2
      DIRECTION.....TRANSMIT

      DATABASE..... .

      COMMAND MODEM ANSWER. .

      TOGGLE TO SELECT THEN PRESS ENTER
      TO TRANSFER
```

Use this utility to transmit the Database to either Port 2/C50S or Port 3A/C21S.

**To transmit the Database:**

- 1** At the PORT parameter, toggle to select the exit port, 2/C50S or 3A/C21S.
- 2** At the DATABASE parameter, toggle to X to enable the transfer.

**To execute the transfer:**

- ▶ Press ENTER./ENT

**COMMAND MODEM ANSWER**

This is used exclusively in an *ASC/3-IM* (Intersection Monitor) setup. When you enable COMMAND MODEM ANSWER, the controller attempts to negotiate with *Aries*. This is only necessary when the *ASC/3-IM* does *not* have the ability to auto-answer, or if the line is already off hook and connected to the *Aries* central office by the operator.

## Sign-On Screen Utility, MM-8-5

```

*****
*   ECONOLITE CONTROL PRODUCTS, INC.   *
*                                     *
*           ASC/3-2100                 *
*       Copyright (C) 2004-2012        *
*                                     *
*       Solutions that Move the World  *
*                                     *
*   CITY.... 0 INTERSECTION.. 0      *
*                                     *
*   SOFTWARE.....V2.52.00           *
*                                     *
*                                     *
*   CONFIGURATION.....N3000         *
*****

```

Use this utility with the numeric keypad in alpha/numeric mode to edit the sign-on screen: the “Solutions that Move the World” line and the CITY and INTERSECTION fields.

The cursor is in the farthest right column in which you can enter characters. Each character you enter goes into that far right column. When you enter a subsequent character, the previous character(s) moves to the left.

### To edit a line:

- 1 Move the cursor to the applicable line.
- 2 To scroll to a character, repeatedly press its key in less than one-second intervals until the correct character comes into view.

---

**Note** • If you use the same key to enter two consecutive characters, wait at least two seconds after you enter the first character.

---

1 enters (space) \* - # , ' & / @ . 1

2 enters A, B, C, a, b, c, 2

3 enters D, E, F, d, e, f, 3

4 enters G, H, I, g, h, i, 4

5 enters J, K, L, j, k, l, 5

6 enters M, N, O, m, n, o, 6

7 enters P, Q, R, p, q, r, 7

8 enters S, T, U, s, t, u, 8

9 enters W, X, Y, Z, w, x, y, z, 9

- *Log Buffers Submenu, MM-8-6*

0 enters 0

**CLEAR** (C for 2070) deletes the entire entry.

< (Cursor Left) clears the character in the far right column.

---

**Note** • **ASC/3 Configurator Software** gives an easy means to edit two lines of the sign-on screen. Refer to the *ASC/3 Configurator User Guide* that comes with every software CD.

---

## Log Buffers Submenu, MM-8-6

Use the utilities in this menu to display, print, or clear the log buffers.

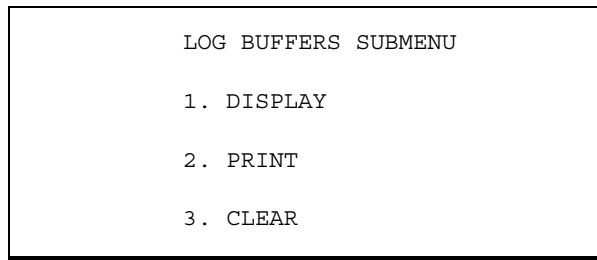

ASC/3 has four different event logs, listed below.

When the controller reaches the maximum limit, it will start to discard the oldest events.

Log Type	Max Events
Controller Events	500
Detector Events	300
Detector Activity	228
MMU Events	50



## Display Log Buffers Submenu, MM-8-6-1

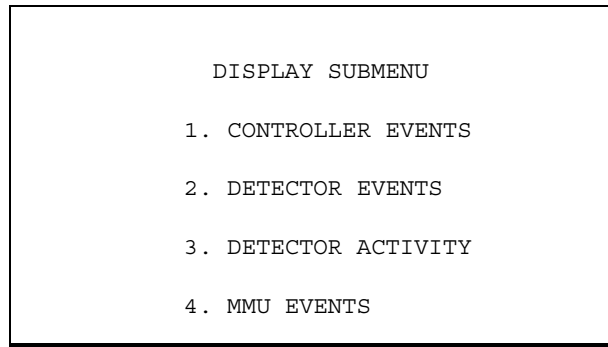

Press a key **1** thru **4** to show a display of the related log buffer: Controller Events, Detector Events, Detector Activity, or MMU Events.

### Navigation Notes

You can scroll a page at a time in MM-8-6-1-1, MM-8-6-1-2, and MM-8-6-1-3. To scroll a page at a time, press **NEXT DATA/D**.

In MM-8-6-1-4, to toggle between the top and bottom part of the screen, press **NEXT DATA/D**.

### Example:

When:

VolOccDets = 10

SpeedDets = 10

TimePeriod = 15 minutes

—and you substitute the values given above in the formulas:

$$\text{RecSize} = 18 + (\text{VolOccDets} * 3) + (\text{SpeedDets})$$

$$18 + (10 * 3) + 10 = 58$$

$$\text{MaxRecs} = 65,088 / \text{RecSize}$$

$$= 1122.2068$$

$$\text{RecsPerDay} = 60 \text{minPerHour} / \text{TimePeriod} * 24$$

$$= (60 / 15 * 24) = 96$$

$$\text{MaxTime} = \text{MaxRecs} / \text{RecsPerDay}$$

$$= 1122.2068 / 96$$

$$= 11.69 \text{ days}$$

- *Print Log Buffers, MM-8-6-2*

## Print Log Buffers, MM-8-6-2

```
PRINT LOG BUFFERS

PRINT TO PORT..... 2
NUMBER OF DAYS..... 10

CONTROLLER EVENTS..... .
DETECTOR EVENTS..... .
DETECTOR ACTIVITY..... .
MMU EVENTS..... .
SELECT ALL..... .

PRESS 0..9 OR TOGGLE TO SELECT
THEN ENTER TO PRINT
```

### To print log buffers to a port:

- 1 Press toggle **0/YES** to select the print output port, Port 2/C50S, Port 3A/C21S, or USB.

---

**Note** • USB is only for a 2070 with a 2070-1C CPU module. You must plug in a USB flash drive (formatted for FAT 16/32) into the USB port of the 2070-1C CPU. When you select USB, the controller prints the selected log events to the text file, LOGPrint.txt, in the USB flash drive.

---

- 2 Enter the number of log days to print.
- 3 As applicable, press toggle **0/YES** to Enable (X) or Disable (.) Controller Events, Detector Events, Detector Activity, MMU Events, or Select All.

### To print the enabled field(s) to the selected port:

- ▶ Press **ENTER/ENT**.

## Clear Submenu, MM-8-6-3

CLEAR SUBMENU
1. CONTROLLER EVENTS
2. DETECTOR EVENTS
3. DETECTOR ACTIVITY
4. MMU EVENTS
5. ALL LOGS

### Use this utility to clear log buffers from memory:

- 1 Press a key **1** thru **4** to select the related log, or press **5** to select all logs.
- 2 To clear the selected log(s), press **ENTER/ENT**.

---

**Note** • When the buffer fills, if the buffers have *not* been cleared, the newest data automatically overwrites the oldest data.

---

## Software Modules, MM-8-7

SOFTWARE MODULES		
NAME	PART NUMBER	VERSION
BOOT	N/A	N/A
APPLICATON	100-1082-250	V2.51.00
CONFIGURATION	100-1049-001	N3000, 8
HELP	100-1050-001	01.00.00
DEFINITIONS	100-1051-001	02.10.00
TEXT	100-1052-001	02.10.00
TELEMETRY	N/A	N/A

This utility displays the name, part number, and version for all installed software modules.

---

**Note** • The Part Number and Version number on your screen should be the same as the numbers applicable to the software actually installed in your system.

---

---

**For your notes:**

## Diagnostics Information

### Front Panel LED Indicator

The front-panel LED logics provide “at-a-glance” status feedback depending on the mode selected, as shown in the tables below. The LED indicates different conditions that depend on the mode of the LED — Tri-Color or Single-Color. To select the LED Mode, refer to *Display Options, MM-1-7-2* on page 6-53.

#### Tri-Color Mode (ASC/3-2100, 1000, RM)

*ASC/3-1000, ASC/3-2100, and ASC/3-RM* support the Tri-Color mode.

Color and Frequency	Indication
YELLOW SOLID	Datakey In Use (Do not remove warning)
YELLOW FAST	Transaction Mode triggered by Keyboard
YELLOW SLOW	Configuration Diagnostic Warning (Refer to <i>Compile and View Active Warnings, MM-9-2-2</i> on page 14-5)
GREEN SOLID	Reserved
GREEN FAST	Reserved
GREEN SLOW	Controller OK
RED SOLID	Boot: Upgrading OS DO NOT POWER OFF
RED FAST	Boot: Could Not Start Traffic Application
RED SLOW	Reserved

## Diagnostics Information

---

- *Single-Color Mode (2070 Controller)*

### Single-Color Mode (2070 Controller)

2070 hardware supports single-color mode. It only has a Red LED.

Color and Frequency	Indication
RED SOLID	Controller OK
RED FAST	Transaction Mode triggered by Keyboard
RED SLOW	Database Diagnostic Warning

## Diagnostics Information, MM-9

DIAGNOSTICS SUBMENU
1. DIAGNOSTICS INFORMATION
2. WARNING CHECKS
3. ADVANCED DIAGNOSTICS

### Diagnostics Information, MM-9-1

DIAGNOSTICS INFORMATION
HARDWARE DIAGNOSTICS ARE PERFORMED WHILE THE CONTROLLER IS NOT OPERATIONAL.
REFER TO APPENDIX F IN THE PROGRAMMING MANUAL FOR INSTRUCTIONS ON LOADING THE DIAGNOSTIC FILE AND ITS OPERATION.

### Warning Check Submenu, MM-9-2

WARNING CHECK SUBMENU
1. ENABLE WARNING CHECK CATEGORIES
2. COMPILE & VIEW ACTIVE WARNINGS
3. VIEW/EDIT DISABLED WARNINGS

## What is a Warning Check?

In the *ASC/3* controller, following a database download or object data alteration via key board, the controller runs Consistency Checks to look for critical errors. If it detects errors, they must be corrected or all database changes are discarded.

After you program the controller, it may appear that a certain feature does not operate correctly, but it may be because of incorrect programming. To call attention to a possible incorrect programmed entry, the controller generates a Warning. The controller generates a Warning if, in the opinion of Econolite, you override the programmed parameter setting from a database with an unusual selection, or select a combination of programmed values that may not give you the operation you probably expect. Warning Checks are intelligent diagnostics designed to tell you of data entries that, by themselves or in combination with other entries, *may* result in unexpected operation.

---

**IMPORTANT** • One thing to keep in mind: a warning is *not* an error.

---

Occasionally, it could be that programming results in “incorrect” operation, but is acceptable to you because it provides a benefit to you that compensates for an occasional operational anomaly. For example, some users routinely program Walk and Pedestrian Clearance times that exceed phase split times in coordinated operation because there are very few pedestrian calls and the user does not mind the occasional coordinator resynchronization that follows the service of a pedestrian call. Because we cannot possibly anticipate what you have in mind, it is left to you to decide what action, if any, to take to correct the situation that caused a Warning message.

Initially, the software framework and a limited set of diagnostics will be available. Warning Checks are viewed as a long-term “work-in-progress”. These checks will be expanded as users and developers find situations that cause an unexpected controller operation.

For a complete list of supported Warning messages, refer to Appendix R, *Warning Checks*.

- Context-Sensitive Warning

## Context-Sensitive Warning

With this feature, the new data can be checked at the time it is entered from the keypad. This includes checking the dependencies with the other parameters; parameters with multiple valid ranges; e.g., 0, 1-10, 20-30. The result of the checks will be displayed immediately. This lets you make the correction or adjustment immediately. For example, if the phase split is set to less than the phase min time, a warning message (see below) is shown. Depending upon the data, the new data could be checked against the other settings. In this example, it also checks if the split sum is greater or less than the cycle length.

```
WARNING(S) :

*Phase split < Phase minimum time
Phase split = 8.0 secs
Timing Plan      1      2      3      4
Min Time (secs) 15.0  12.0  10.0   9.0

*Split sum < Cycle length (100 secs)
Rings      Split sum
 1 2          80 secs

Press [CLEAR] key 3 times in this screen
to suppress warning check in next 30 sec
```

## Enable Warning Check Categories, MM-9-2-1

```
WARNING CHECK SELECTION - DISABLE ALL
WARNING CHECK          ENABLED
1. CONFIGURATION      NO
2. CONTROLLER         NO
3. COORDINATOR        NO
4. PREEMPTOR/TSP     NO
5. TIME BASE          NO
6. DETECTORS          NO
7. AT DATA ENTRY    NO

NOTE: Controller automatically performs
Warning Check at power up only.
User should run Warning Check with
MM-9-2-2 after data entry changes.
Individual Warnings can be disabled
at MM-9-2-3
```

Use this display to select the warning check categories.

### To enable or disable all the warning check categories:

- ▶ On the first line, toggle to select ENABLE ALL or DISABLE ALL.



**To individually enable/disable the warning check categories:**

- 1** On the first line, toggle to select COMMANDS.
- 2** Cursor to the respective line to individually select YES to enable or NO to disable the seven warning check categories:
  1. Configuration
  2. Controller
  3. Coordinator
  4. Preemptor/TSP
  5. Time Base
  6. Detectors
  7. At Data Entry

---

**Note** • The default is DISABLE ALL.

---

## Compile and View Active Warnings, MM-9-2-2

When you select this display, the controller runs all enabled Warning Checks. If any warning(s) is detected, it is shown on the display. An example display is shown below.

### Example Warnings Display

```
ACTIVE DIAGNOSTIC WARNING CHECKS (WC)
1201 Inactive Exclusive Ped Phase
1202 In-use phase not in sequence
3101 Manual Pattern enabled
4104 Preempt MAX Presence time enabled
```

When in a **hyperlink** field:

**To follow the hyperlink:**

For ASC/3, press **SPEC FUNC**, then **NEXT DATA**.

For 2070, press **B**.

**To go back:**

For ASC/3, press **SUB MENU**.

For 2070, press **ESC**.

- *Compile and View Active Warnings, MM-9-2-2*

When you move the cursor to one of the warning messages, the options that follow are available:

Press at the Warning Line	Action
Hyperlink keys <b>SPEC FUNC + NEXT DATA</b> (2070: * + D)	This takes you to MM-9-2-3 where you can suppress the particular warning.
<b>HELP/F</b>	See more information about the warning. For example, text associated with “Yellow Clear Override” might reference the relevant NEMA and/or NTCIP paragraph, explain why the message was generated and show a list of the phases with this <i>apparent</i> error—remember that a warning check is not an error, just something that does not look correct. You can scroll through this help text. Below is an example of a help display for a warning.
<b>ENTER/ENT</b>	It will take you to the data entry screen, where you can make changes to avoid the particular warning. You can also press this key while in HELP for this warning.

### Example Help Display for a Warning

```

2103 Ped Clear Override

Phase Ped Clear timing (MM-2-1) will be
Overridden by Guaranteed Minimum Ped
Clear (MM-2-4) on the following

PHASES:
2

The indicated problem may be on any of
four possible timing plans - be sure to
check each timing plan.
    
```

If no warning diagnostics are generated, “THERE ARE NO WARNINGS TO BE DISPLAYED” is shown.

#### If you want to disable a warning check in the future runs:

- 1 Move the cursor to the warning message.
- 2 At the same time, press **SPEC FUNC** and **NEXT DATA** ( for 2070, \* and D).
- 3 MM-9-2-3 comes into view with the specified warning number selected.
- 4 Use the **DISABLE** command to suppress this warning check in future runs.

The first two digits of the warning number indicate the first two levels of the display in which the associated data is programmed.

**Example:** 3101 = Manual Pattern Enabled

The manual pattern is enabled in MM-3-1.

For a complete list of supported warnings, refer to Appendix R, *Warning Checks*.

### *Edit/View Disabled Warnings, MM-9-2-3*

You can use this display to disable up to 40 Warning Checks.

#### **To disable a Warning Check:**

- 1** Enter the Warning Number in the square brackets, [ ].
- 2** Move the cursor to the right to COMMANDS.
- 3** The name of the Warning comes into view on the second line.
- 4** Toggle to ENABLE or DISABLE the Warning.
- 5** Move the cursor.
- 6** The Warning Number comes into view in the list of DISABLED WARNING CHECKS. These are shown in ascending order.

#### **Example Disabled Warnings Display**

```
WARNING CHECKS [1201]    COMMANDS    .  
Inactive Exclusive Ped Phase  
DISABLED WARNING CHECKS:  
2101 2102 3101 3201 3202 3301 3302 3304
```

- Startup Warning Message

## Startup Warning Message

When you apply power, the controller runs the enabled Warning Checks. If any Warnings are found, the display below comes into view. Warning Check is only run at power up automatically. It is highly recommended to run warning check (MM-9-2-2) after a configuration change.

### Startup Warning Display

```
STATUS [CORD SYS P120] MM/DD/YY|HH:MM:SS
  PHASE 1 2 3 4 5 6 7 8 9 0 1 2 3 4 5 6
PH STAT . G R R G R R R - - - - -
VEH CALL . I I . . . . .
*****
*   DATABASE IRREGULARITIES FOUND   *
*   GO TO MM-9-2-2 FOR DETAILS.     *
*                                     *
*   TO DISABLE A SPECIFIC WARNING,  *
*   GO TO MM-9-2-3.                 *
*****
PMT|TSP ■ ■ ■ ■ ■ ■ ■ ■ ■ |X X X X X X
LP FLAG . A . . . A . . . . .
COMMUNICATIONS PORT STATUS|TLM ADD: 0
ETH RX TX|P2  RX TX|P3A RX TX|P3B RX TX
2  .- .-|1  OK OK|3  ID  |3  .. ..
```

**When in a **hyperlink** field:**

**To follow the hyperlink:**

For ASC/3, press **SPEC FUNC**, then **NEXT DATA**.

For 2070, press **B**.

**To go back:**

For ASC/3, press **SUB MENU**.

For 2070, press **ESC**.



# ASC/3, ASC/3-2070 & ASC/3-LX Menu Tree

## MM-1 CONFIGURATION

- MM-1-1 CONTROLLER SEQUENCE
  - MM-1-1-1 PHASE RING SEQUENCE AND ASSIGNMENT
  - MM-1-1-2 PHASE COMPATIBILITY
  - MM-1-1-3 BACKUP PREVENT PHASES
  - MM-1-1-4 SIMULTANEOUS GAP PHASES
  - MM-1-1-5 DIAMOND SEQUENCE 17 TO 20
    - MM-1-1-5-1 PHASE RING SEQUENCE & ASSIGNMENT
    - MM-1-1-5-2 PHASE COMPATIBILITY
    - MM-1-1-5-3 BACKUP PREVENT PHASES
- MM-1-2 PHASE IN USE/EXCLUSIVE PED
- MM-1-3 LOAD SW ASSIGNMENT
- MM-1-4 PORT 1 (SDLC)
  - MM-1-4-1 SDLC OPTIONS
  - MM-1-4-2 MMU PROGRAM
  - MM-1-4-3 COLOR CHECK ENABLE
  - MM-1-4-4 SECONDARY STATIONS/TESTS
- MM-1-5 COMM PORTS
  - MM-1-5-1 ETHERNET
  - MM-1-5-2 PORT 2/C50S
  - MM-1-5-3 PORT 3A/C21S
  - MM-1-5-4 PORT 3B/C22S
  - MM-1-5-5 NTCIP
  - MM-1-5-6 ECIPI
- MM-1-6 ENABLE LOGGING
  - MM-1-6-1 EVENT LOGGING
- MM-1-7 DISPLAY/ACCESS
  - MM-1-7-1 ADMINISTRATION
  - MM-1-7-2 DISPLAY OPTIONS
  - MM-1-7-3 SECURITY ACCESS
- MM-1-8 LOGIC PROCESSOR
  - MM-1-8-1 LOGIC STATEMENT CONTROL
  - MM-1-8-2 LOGIC STATEMENTS

## MM-2 CONTROLLER

- MM-2-1 TIMING PLANS
- MM-2-2 VEHICLE OVERLAPS
- MM-2-3 VEH/PED OVERLAPS
- MM-2-4 GUARANTEED MIN TIME
- MM-2-5 START/FLASH
- MM-2-6 OPTION DATA
  - MM-2-6-1 CONTROLLER OPTIONS
  - MM-2-6-2 EXTENDED OPTIONS
- MM-2-7 ACTUATED PRE-TIMED MODE
- MM-2-8 PHASE RECALL OPTIONS

## MM-3 COORDINATOR

- MM-3-1 COORDINATOR OPTIONS
- MM-3-2 COORDINATOR PATTERNS
- MM-3-3 SPLIT PATTERNS
- MM-3-4 AUTO PERM MIN GREEN
- MM-3-5 SPLIT DEMAND

## MM-4 PREEMPTOR/TSP/SCP

- MM-4-1 PREEMPT PLAN 1-10
- MM-4-2 ENABLE PREEMPT FILTERING & TSP/SCP
- MM-4-3 TSP/SCP PLAN 1-6
- MM-4-4 TSP/SCP SPLIT PATTERN

## MM-5 TIME BASE

- MM-5-1 CLOCK/CALENDAR DATA
- MM-5-2 ACTION PLAN
- MM-5-3 DAY PLAN/EVENT
- MM-5-4 SCHEDULE NUMBER
- MM-5-5 EXCEPTION DAYS

## MM-6 DETECTORS

- MM-6-1 VEHICLE DETECTOR PHASE ASSIGNMENT
- MM-6-2 VEHICLE DETECTOR SETUP

## MM-6-3 PEDESTRIAN DETECTOR INPUT ASSIGNMENT

- MM-6-4 LOG INTERVAL/SPEED DETECTOR SETUP
- MM-6-5 VEHICLE DETECTOR DIAGNOSTICS
- MM-6-6 PEDESTRIAN DETECTOR DIAGNOSTICS

## MM-7 STATUS DISPLAY

- MM-7-1 CONTROLLER
- MM-7-2 COORDINATOR
- MM-7-3 PREEMPTORS & TSP/SCP
  - MM-7-3-1 PREEMPTORS
  - MM-7-3-2 TSP/SCP
- MM-7-4 TBC/ACTION PLANS
- MM-7-5 COMMUNICATIONS
  - MM-7-5-1 ETHERNET
  - MM-7-5-2 PORT [2 or C50S]
  - MM-7-5-3 PORT [3A or C21S]
  - MM-7-5-4 PORT [3B or C22S]
  - MM-7-5-5 NTCIP
  - MM-7-5-6 ECIPI
  - MM-7-5-7 IEEE 1570
- MM-7-6 DETECTORS
- MM-7-7 FLASH/SDLC/MMU STATUS
  - MM-7-7-1 FLASH STATUS
  - MM-7-7-2 SDLC STATUS
  - MM-7-7-3 MMU STATUS
  - MM-7-7-4 MMU EXTENDED STATUS
  - MM-7-7-5 MMU AC STATUS
  - MM-7-7-6 MMU COMPATIBILITY
- MM-7-8 INPUT/OUTPUT STATUS
  - MM-7-8-1 CONTROLLER INPUTS [NEMA or 2070 C1/C11 INPUT FUNCTIONS]
  - MM-7-8-2 CONTROLLER OUTPUTS [NEMA or 2070 C1/C11 OUTPUT FUNCTIONS]
  - MM-7-8-3 HARDWARE INPUTS [NEMA ABC or 2070 C1/C11 INPUTS]
  - MM-7-8-4 HARDWARE OUTPUTS [NEMA ABC or 2070 C1/C11 OUTPUTS]
  - MM-7-8-5 AUX HARDWARE I/O [ASC3 D & T or 2070 D HW I/O]
  - MM-7-8-6 T&F BIU I/O
  - MM-7-8-7 D/R BIU I/O
  - MM-7-8-8 LOGIC PROCESSOR
    - MM-7-8-8-1 LOGIC PROCESSOR GATE
    - MM-7-8-8-2 LOGIC PROCESSOR ENABLE PLAN
  - MM-7-8-9 I/O DIFFERENCES

## MM-8 UTILITIES

- MM-8-1 COPY
- MM-8-2 USB MANAGEMENT
- MM-8-3 PRINT
- MM-8-4 TRANSFER
- MM-8-5 SIGN ON
- MM-8-6 LOG BUFFERS
  - MM-8-6-1 DISPLAY
    - MM-8-6-1-1 CONTROLLER EVENTS
    - MM-8-6-1-2 DETECTOR EVENTS
    - MM-8-6-1-3 DETECTOR ACTIVITY
    - MM-8-6-1-4 MMU EVENTS
  - MM-8-6-2 PRINT LOG BUFFERS
  - MM-8-6-3 CLEAR
    - MM-8-6-3-1 CONTROLLER EVENTS
    - MM-8-6-3-2 DETECTOR EVENTS
    - MM-8-6-3-3 DETECTOR ACTIVITY
    - MM-8-6-3-4 MMU EVENTS
    - MM-8-6-3-5 ALL LOGS
- MM-8-7 SOFTWARE MODULES

## MM-9 DIAGNOSTICS

- MM-9-1 DIAGNOSTICS INFORMATION
- MM-9-2 WARNING CHECKS
  - MM-9-2-1 ENABLE WARNING CHECK CATEGORIES
  - MM-9-2-2 COMPILER & VIEW ACTIVE WARNINGS
  - MM-9-2-3 VIEW/EDIT DISABLED WARNINGS

---

**For your notes:**

## ASC/3 Screens

The LCD display on the Econolite *ASC/3* controller is 16 lines vertical by 40 characters horizontal. Some of the screens in this appendix contain more than 16 lines and/or more than 40 characters in a line. In those cases, use the cursor keys to scroll the display vertically and/or horizontally to move through the display. For screen size and navigation for both *ASC/3* and *2070* screens, refer to Chapter 5, *MAIN MENU and Screen Navigation*.

Screen titles, above the screen illustrations, show the keys to press to navigate to that screen. For example, to go to screen **MM-1-4-3**, press **MAIN MENU** then **1** then **4** then **3**.

POWER ON automatically shows one of these three screens:

```
*****
*   ECONOLITE CONTROL PRODUCTS INC.   *
*                                     *
*           ASC/3-2100                 *
*       Copyright (C) 2004-2012        *
*                                     *
*   Solutions that Move the World     *
*                                     *
* CITY....  0 INTERSECTION..  0      *
*                                     *
* SOFTWARE.....v2.59.00              *
*                                     *
* CONFIGURATION. ....N3000*          *
*                                     *
*           WARM START                 *
*                                     *
*****
```

```
Power up flash
corrupted file system

MISSING APPLICATION FILES

THE CONTROLLER HAS MISSING OR
CORRUPTED APPLICATION FILES.
REFER TO THE ASC/3 PROGRAMMING
MANUAL FOR INSTRUCTIONS ON LOADING
NEW OPERATIONAL FILES.
PRESS ANY KEY TO CONTINUE.
```

```
STATUS [CORD SYS P120] MM/DD/YY|HH:MM:SS
  PHASE 1 2 3 4 5 6 7 8 9 0 1 2 3 4 5 6
PH STAT . G R R G R R R - - - - -
VEH CALL . I I . . . . .
PED CALL . . . . .
R1/PH 04|R2/PH 08|R3/PH ..|R4/PH ..
MGR1 0.0|YEL 0.0|INACTIVE |INACTIVE
PDCL 12.0|FORCE OFF|
PLAN SPLT: 12|TP: 4|SEQ: 1|ACT: 100|DP: 4
LC: 115s/120|SYS CYC: 110s|COS 111|COORD
FUNCTION 1 2 3 4 5 6 7 8 9 0 1 2 3 4 5 6
PMT|TSP ■ ■ ■ ■ ■ ■ ■ ■ ■ ■ ■ ■ ■ ■ ■ ■
LP FLAG . A . . . A . . . . .
COMMUNICATIONS PORT STATUS|TIM ADD: 0
ETH RX TX|P2 RX TX|P3A RX TX|P3B RX TX
2 - -|1 OK OK|3 IE |3 ■ ■
```

▪ Appendix B

**MM**

```

MAIN MENU

1. CONFIGURATION      6. DETECTORS
2. CONTROLLER         7. STATUS DISPLAY
3. COORDINATOR        8. UTILITIES
4. PREEMPTOR/TSP     9. DIAGNOSTICS
5. TIME BASE
    
```

**MM-1**

```

CONFIGURATION SUBMENU

1. CONTROLLER SEQ    5. COMMUNICATIONS
2. PHASE IN USE/PED 6. ENABLE LOGGING
3. LOAD SW ASSIGN    7. DISPLAY/ACCESS
4. PORT 1 (SDLC)    8. LOGIC PROCESSOR
    
```

**MM-1-1**

```

CONTROLLER SEQUENCE SUBMENU

1. PHASE RING SEQUENCE AND ASSIGNMENT
2. PHASE COMPATIBILITY
3. BACKUP PREVENT PHASES
4. SIMULTANEOUS GAP PHASES
5. DIAMOND SEQUENCE 17 TO 20
    
```

**MM-1-1-1**

```

CONTROLLER SEQUENCE [ 1 ]
SEQUENCE COMMANDS . HW ALT SEQ ENA.          NO
      01 02 03 04 05 06 07 08 09 10 11 12 13 14 15 16
BC-B - B - B - - - - - - - - - - - - - -
R1- 01 02 03 04 . . . . . . . . . . . . . .
R2- 06 05 07 08 . . . . . . . . . . . . . .
R3- . . . . . . . . . . . . . . . . . . . .
R4- . . . . . . . . . . . . . . . . . . . .

R1-R4=RING 1-4, DATA ENTRY, PHASES 1-16
BC=BARRIER CONTROL, VALUES: B,C
B= BARRIER MODE
C=COMPATIBILITY MODE
    
```

**MM-1-1-2**

```

PHASE COMPATIBILITY      ^
      6 5 4 3 2 1 0 9 8 7 6 5 4 3 2
1 . . . . . . . . . . . . . . . . . . . .
2 . . . . . . . . . . . . . . . . . . . .
3 . . . . . . . . . . . . . . . . . . . .
4 . . . . . . . . . . . . . . . . . . . .
5 . . . . . . . . . . . . . . . . . . . .
6 . . . . . . . . . . . . . . . . . . . .
7 . . . . . . . . . . . . . . . . . . . .
8 . . . . . . . . . . . . . . . . . . . .
9 . . . . . . . . . . . . . . . . . . . .
10 . . . . . . . . . . . . . . . . . . . .
11 . . . . . . . . . . . . . . . . . . . .
12 . . . . . . . . . . . . . . . . . . . .
13 . . . . . . . . . . . . . . . . . . . .
14 . . . . . . . . . . . . . . . . . . . .
15 . . . . . . . . . . . . . . . . . . . .
    
```

**MM-1-1-3**

```

ENABLE BACKUP PREVENT
TMG\BKUP 1 2 3 4 5 6 7 8 9 0 1 2 3 4 5 6
1 . . . . . . . . . . . . . . . . . . . .
2 B . . . . . . . . . . . . . . . . . . . .
3 . . . . . . . . . . . . . . . . . . . .
4 . C B . . . . . . . . . . . . . . . . . .
5 . . . . . . . . . . . . . . . . . . . .
6 . . . . . B . . . . . . . . . . . . . . .
7 . . . . . . . . . . . . . . . . . . . .
8 . . . . . C B . . . . . . . . . . . . . .
9 . . . . . . . . . . . . . . . . . . . .
10 . . . . . . . . . . X . . . . . . . . . .
11 . . . . . . . . . . . . . . . . . . . .
12 . . . . . . . . . . . X . . . . . . . . .
13 . . . . . . . . . . . . . . . . . . . .
14 . . . . . . . . . . . . . . . . . . . .
15 . . . . . . . . . . . . . . . . . . . .
16 . . . . . . . . . . . . . . . . . . . .
    
```



**MM-1-1-4**

```

SIMULTANEOUS GAP PHASES
GAP\PH  1 2 3 4 5 6 7 8 9 0 1 2 3 4 5 6
  1 . . . . X X . . . . . . . . . .
  2 . . . . X X . . . . . . . . . .
  3 . . . . . . X X . . . . . . . .
  4 . . . . . . X X . . . . . . . .
  5 X X . . . . . . . . . . . . . .
  6 X X . . . . . . . . . . . . . .
  7 . . X X . . . . . . . . . . . .
  8 . . X X . . . . . . . . . . . .
  9 . . . . . . . . X X . . . . . .
 10 . . . . . . . . X X . . . . . .
 11 . . . . . . X X . . . . . . . .
 12 . . . . . . X X . . . . . . . .
 13 . . . . . . . . . . . . X X . .
 14 . . . . . . . . . . . . X X . .
 15 . . . . . . . . . . X X . . . .
 16 . . . . . . . . . . X X . . . .
DISABLE. . . . . . . . . . . . . .
    
```

**MM-1-1-5**

```

DIAMOND SEQUENCE 17 TO 20 SUBMENU

1. PHASE RING SEQUENCE AND ASSIGNMENT
2. PHASE COMPATIBILITY
3. BACKUP PREVENT PHASES
    
```

**MM-1-1-5-1**

```

PHASE RING ASSIGNMENT
SEQUENCE 17
RING 1  2 3 4 9 11 12 1 0 0 0 0
RING 2 15 16 5 6 7 8 13 0 0 0 0
RING 3  0 0 0 0 0 0 0 0 0 0 0 0
RING 4  0 0 0 0 0 0 0 0 0 0 0 0

      PHASE  1 2 3 4 5 6 7 8
RING.....  1 1 1 1 2 2 2 2
      PHASE  9 10 11 12 13 14 15 16
RING.....  1 0 1 1 2 0 2 2

SEQUENCE 18
RING 1 10 4 9 3 2 1 0 0 0 0 0
RING 2 14 8 13 7 6 5 0 0 0 0 0
RING 3  0 0 0 0 0 0 0 0 0 0 0 0
RING 4  0 0 0 0 0 0 0 0 0 0 0 0

      PHASE  1 2 3 4 5 6 7 8
RING.....  1 1 1 1 2 2 2 2
      PHASE  9 10 11 12 13 14 15 16
RING.....  1 1 0 0 2 2 0 0
    
```

**MM-1-1-5-1 (continued)**

```

SEQUENCE 19
RING 1  1 2 3 4 0 0 0 0 0 0 0 0
RING 2  5 6 7 8 0 0 0 0 0 0 0 0
RING 3  0 0 0 0 0 0 0 0 0 0 0 0
RING 4  0 0 0 0 0 0 0 0 0 0 0 0

      PHASE  1 2 3 4 5 6 7 8
RING.....  1 1 1 1 2 2 2 2
      PHASE  9 10 11 12 13 14 15 16
RING.....  0 0 0 0 0 0 0 0

SEQUENCE 20
RING 1  1 2 3 4 0 0 0 0 0 0 0 0
RING 2  5 6 7 8 0 0 0 0 0 0 0 0
RING 3  0 0 0 0 0 0 0 0 0 0 0 0
RING 4  0 0 0 0 0 0 0 0 0 0 0 0

      PHASE  1 2 3 4 5 6 7 8
RING.....  1 1 1 1 2 2 2 2
      PHASE  9 10 11 12 13 14 15 16
RING.....  0 0 0 0 0 0 0 0
    
```

▪ Appendix B

**MM-1-1-5-2**

**MM-1-1-5-2 (continued)**

PHASE COMPATIBILITY																	
SEQUENCE 17												1	1	1	1	1	1
1	2	3	4	5	6	7	8	9	0	1	2	3	4	5	6		
1	.	.	.	.	X	X	X	.	.	.	.	X	.	.	.		
2	.	.	.	X	.	.	.	.	.	.	.	.	.	X	X		
3	.	.	.	X	.	.	.	.	.	.	.	.	.	.	.		
4	.	.	.	X	.	.	.	.	.	.	.	.	.	.	.		
5	.	X	X	X	.	.	.	X	.	.	.	.	.	.	.		
6	X	.	.	.	.	.	.	.	X	X	.	.	.	.	.		
7	X	.	.	.	.	.	.	.	.	.	.	.	.	.	.		
8	X	.	.	.	.	.	.	.	.	.	.	.	.	.	.		
9	.	.	.	X	.	.	.	.	.	.	.	.	.	.	.		
10	.	.	.	.	.	.	.	.	.	.	.	.	.	.	.		
11	.	.	.	.	X	.	.	.	.	.	.	.	.	.	.		
12	.	.	.	.	X	.	.	.	.	.	.	.	.	.	.		
13	X	.	.	.	.	.	.	.	.	.	.	.	.	.	.		
14	.	.	.	.	.	.	.	.	.	.	.	.	.	.	.		
15	.	X	.	.	.	.	.	.	.	.	.	.	.	.	.		
16	.	X	.	.	.	.	.	.	.	.	.	.	.	.	.		

PHASE COMPATIBILITY																	
SEQUENCE 18												1	1	1	1	1	1
1	2	3	4	5	6	7	8	9	0	1	2	3	4	5	6		
1	.	.	.	X	X	.	.	.	.	.	.	.	.	.	.		
2	.	.	.	X	X	.	.	.	.	.	.	.	.	.	.		
3	.	.	.	.	.	X	.	.	.	.	X	.	.	.	.		
4	.	.	.	.	.	X	.	.	.	.	X	.	.	.	.		
5	X	X	.	.	.	.	.	.	.	.	.	.	.	.	.		
6	X	X	.	.	.	.	.	.	.	.	.	.	.	.	.		
7	.	X	.	.	.	.	X	.	.	.	.	.	.	.	.		
8	.	.	X	.	.	.	.	X	.	.	.	.	.	.	.		
9	.	.	.	.	X	.	.	.	X	.	.	.	.	.	.		
10	.	.	.	.	.	X	.	.	.	X	.	.	.	.	.		
11	.	.	.	.	.	.	.	.	.	.	.	.	.	.	.		
12	.	.	.	.	.	.	.	.	.	.	.	.	.	.	.		
13	.	X	.	.	.	.	X	.	.	.	.	.	.	.	.		
14	.	.	X	.	.	.	.	X	.	.	.	.	.	.	.		
15	.	.	.	.	.	.	.	.	.	.	.	.	.	.	.		
16	.	.	.	.	.	.	.	.	.	.	.	.	.	.	.		

PHASE COMPATIBILITY																	
SEQUENCE 19												1	1	1	1	1	1
1	2	3	4	5	6	7	8	9	0	1	2	3	4	5	6		
1	.	.	.	X	X	X	X	.	.	.	.	.	.	.	.		
2	.	.	.	X	X	X	X	.	.	.	.	.	.	.	.		
3	.	.	.	X	X	X	X	.	.	.	.	.	.	.	.		
4	.	.	.	X	X	X	X	.	.	.	.	.	.	.	.		
5	X	X	X	X	.	.	.	.	.	.	.	.	.	.	.		
6	X	X	X	X	.	.	.	.	.	.	.	.	.	.	.		
7	X	X	X	X	.	.	.	.	.	.	.	.	.	.	.		
8	X	X	X	X	.	.	.	.	.	.	.	.	.	.	.		
9	.	.	.	.	.	.	.	.	.	.	.	.	.	.	.		
10	.	.	.	.	.	.	.	.	.	.	.	.	.	.	.		
11	.	.	.	.	.	.	.	.	.	.	.	.	.	.	.		
12	.	.	.	.	.	.	.	.	.	.	.	.	.	.	.		
13	.	.	.	.	.	.	.	.	.	.	.	.	.	.	.		
14	.	.	.	.	.	.	.	.	.	.	.	.	.	.	.		
15	.	.	.	.	.	.	.	.	.	.	.	.	.	.	.		
16	.	.	.	.	.	.	.	.	.	.	.	.	.	.	.		

PHASE COMPATIBILITY																	
SEQUENCE 20												1	1	1	1	1	1
1	2	3	4	5	6	7	8	9	0	1	2	3	4	5	6		
1	.	.	.	X	X	.	.	.	.	.	.	.	.	.	.		
2	.	.	.	X	X	.	.	.	.	.	.	.	.	.	.		
3	.	.	.	.	.	X	X	.	.	.	.	.	.	.	.		
4	.	.	.	.	.	X	X	.	.	.	.	.	.	.	.		
5	X	X	.	.	.	.	.	.	.	.	.	.	.	.	.		
6	X	X	.	.	.	.	.	.	.	.	.	.	.	.	.		
7	.	X	X	.	.	.	.	.	.	.	.	.	.	.	.		
8	.	X	X	.	.	.	.	.	.	.	.	.	.	.	.		
9	.	.	.	.	.	.	.	.	.	.	.	.	.	.	.		
10	.	.	.	.	.	.	.	.	.	.	.	.	.	.	.		
11	.	.	.	.	.	.	.	.	.	.	.	.	.	.	.		
12	.	.	.	.	.	.	.	.	.	.	.	.	.	.	.		
13	.	.	.	.	.	.	.	.	.	.	.	.	.	.	.		
14	.	.	.	.	.	.	.	.	.	.	.	.	.	.	.		
15	.	.	.	.	.	.	.	.	.	.	.	.	.	.	.		
16	.	.	.	.	.	.	.	.	.	.	.	.	.	.	.		

**MM-1-1-5-3**

BACKUP PREVENT PHASES																				
SEQUENCE	17												1	1	1	1	1	1	1	
		1	2	3	4	5	6	7	8	9	0	1	2	3	4	5	6			
	1	.	.	.	.	.	.	.	.	.	.	.	.	.	.	.	.	.	.	.
	2	.	.	.	.	.	.	.	.	.	.	.	.	.	.	.	.	.	.	.
	3	.	.	.	.	.	.	.	.	.	.	.	.	.	.	.	.	.	.	.
	4	.	.	.	.	.	.	.	.	.	.	.	.	.	.	.	.	.	.	.
TIMING	5	.	.	.	.	.	.	.	.	.	.	.	.	.	.	.	.	.	.	.
	6	.	.	.	.	.	.	.	.	.	.	.	.	.	.	.	.	.	.	.
	7	.	.	.	.	.	.	.	.	.	.	.	.	.	.	.	.	.	.	.
	8	.	.	.	.	.	.	.	.	.	.	.	.	.	.	.	.	.	.	.
	9	.	.	.	.	.	.	.	.	.	.	.	.	.	.	.	.	.	.	.
	10	.	.	.	.	.	.	.	.	.	.	.	.	.	.	.	.	.	.	.
	11	.	.	.	.	.	.	.	.	.	.	.	.	.	.	.	.	.	.	.
	12	.	.	.	.	.	.	.	.	.	.	.	.	.	.	.	.	.	.	.
	13	.	.	.	.	.	.	.	.	.	.	.	.	.	.	.	.	.	.	.
	14	.	.	.	.	.	.	.	.	.	.	.	.	.	.	.	.	.	.	.
	15	.	.	.	.	.	.	.	.	.	.	.	.	.	.	.	.	.	.	.
	16	.	.	.	.	.	.	.	.	.	.	.	.	.	.	.	.	.	.	.
BACKUP PREVENT PHASES																				
SEQUENCE	18												1	1	1	1	1	1	1	
		1	2	3	4	5	6	7	8	9	0	1	2	3	4	5	6			
	1	.	.	.	.	.	.	.	.	.	.	.	.	.	.	.	.	.	.	.
	2	.	.	.	.	.	.	.	.	.	.	.	.	.	.	.	.	.	.	.
	3	.	.	.	.	.	.	.	.	.	.	.	.	.	.	.	.	.	.	.
	4	.	.	.	.	.	.	.	.	.	.	.	.	.	.	.	.	.	.	.
TIMING	5	.	.	.	.	.	.	.	.	.	.	.	.	.	.	.	.	.	.	.
	6	.	.	.	.	.	.	.	.	.	.	.	.	.	.	.	.	.	.	.
	7	.	.	.	.	.	.	.	.	.	.	.	.	.	.	.	.	.	.	.
	8	.	.	.	.	.	.	.	.	.	.	.	.	.	.	.	.	.	.	.
	9	.	.	.	.	.	.	.	.	.	.	.	.	.	.	.	.	.	.	.
	10	.	.	.	.	.	.	.	.	.	.	.	.	.	.	.	.	.	.	.
	11	.	.	.	.	.	.	.	.	.	.	.	.	.	.	.	.	.	.	.
	12	.	.	.	.	.	.	.	.	.	.	.	.	.	.	.	.	.	.	.
	13	.	.	.	.	.	.	.	.	.	.	.	.	.	.	.	.	.	.	.
	14	.	.	.	.	.	.	.	.	.	.	.	.	.	.	.	.	.	.	.
	15	.	.	.	.	.	.	.	.	.	.	.	.	.	.	.	.	.	.	.
	16	.	.	.	.	.	.	.	.	.	.	.	.	.	.	.	.	.	.	.

**MM-1-1-5-3 (continued)**

BACKUP PREVENT PHASES																				
SEQUENCE	19												1	1	1	1	1	1	1	
		1	2	3	4	5	6	7	8	9	0	1	2	3	4	5	6			
	1	.	.	.	.	.	.	.	.	.	.	.	.	.	.	.	.	.	.	.
	2	.	.	.	.	.	.	.	.	.	.	.	.	.	.	.	.	.	.	.
	3	.	.	.	.	.	.	.	.	.	.	.	.	.	.	.	.	.	.	.
	4	.	.	.	.	.	.	.	.	.	.	.	.	.	.	.	.	.	.	.
TIMING	5	.	.	.	.	.	.	.	.	.	.	.	.	.	.	.	.	.	.	.
	6	.	.	.	.	.	.	.	.	.	.	.	.	.	.	.	.	.	.	.
	7	.	.	.	.	.	.	.	.	.	.	.	.	.	.	.	.	.	.	.
	8	.	.	.	.	.	.	.	.	.	.	.	.	.	.	.	.	.	.	.
	9	.	.	.	.	.	.	.	.	.	.	.	.	.	.	.	.	.	.	.
	10	.	.	.	.	.	.	.	.	.	.	.	.	.	.	.	.	.	.	.
	11	.	.	.	.	.	.	.	.	.	.	.	.	.	.	.	.	.	.	.
	12	.	.	.	.	.	.	.	.	.	.	.	.	.	.	.	.	.	.	.
	13	.	.	.	.	.	.	.	.	.	.	.	.	.	.	.	.	.	.	.
	14	.	.	.	.	.	.	.	.	.	.	.	.	.	.	.	.	.	.	.
	15	.	.	.	.	.	.	.	.	.	.	.	.	.	.	.	.	.	.	.
	16	.	.	.	.	.	.	.	.	.	.	.	.	.	.	.	.	.	.	.
BACKUP PREVENT PHASES																				
SEQUENCE	20												1	1	1	1	1	1	1	
		1	2	3	4	5	6	7	8	9	0	1	2	3	4	5	6			
	1	.	.	.	.	.	.	.	.	.	.	.	.	.	.	.	.	.	.	.
	2	.	.	.	.	.	.	.	.	.	.	.	.	.	.	.	.	.	.	.
	3	.	.	.	.	.	.	.	.	.	.	.	.	.	.	.	.	.	.	.
	4	.	.	.	.	.	.	.	.	.	.	.	.	.	.	.	.	.	.	.
TIMING	5	.	.	.	.	.	.	.	.	.	.	.	.	.	.	.	.	.	.	.
	6	.	.	.	.	.	.	.	.	.	.	.	.	.	.	.	.	.	.	.
	7	.	.	.	.	.	.	.	.	.	.	.	.	.	.	.	.	.	.	.
	8	.	.	.	.	.	.	.	.	.	.	.	.	.	.	.	.	.	.	.
	9	.	.	.	.	.	.	.	.	.	.	.	.	.	.	.	.	.	.	.
	10	.	.	.	.	.	.	.	.	.	.	.	.	.	.	.	.	.	.	.
	11	.	.	.	.	.	.	.	.	.	.	.	.	.	.	.	.	.	.	.
	12	.	.	.	.	.	.	.	.	.	.	.	.	.	.	.	.	.	.	.
	13	.	.	.	.	.	.	.	.	.	.	.	.	.	.	.	.	.	.	.
	14	.	.	.	.	.	.	.	.	.	.	.	.	.	.	.	.	.	.	.
	15	.	.	.	.	.	.	.	.	.	.	.	.	.	.	.	.	.	.	.
	16	.	.	.	.	.	.	.	.	.	.	.	.	.	.	.	.	.	.	.

**MM-1-2**

PHASES IN USE / EXCLUSIVE PED																
		PHASE	1	2	3	4	5	6	7	8						
IN USE.....			X	X	X	X	X	X	X	X						
EXCLUSIVE PED			.	.	.	.	.	.	.	.						
		PHASE	9	10	11	12	13	14	15	16						
IN USE.....			X	.	.	.	.	.	.	.						
EXCLUSIVE PED			X	.	.	.	.	.	.	.						

**MM-1-3**

LD SWITCH ASSIGN																
		PHASE	DIMMING ---FLASH---													
		/OVLDP	TYPE	R	Y	G	D	PWR	AUT	TGR						
1	1	O	.	.	.	.	+	X	.	.	.					
2	2	O	.	.	.	.	+	X	.	.	.					
3	3	O	.	.	.	.	+	X	.	.	.					
4	4	O	.	.	.	.	+	X	.	.	.					
5	5	O	.	.	.	.	+	X	.	.	.					
6	6	O	.	.	.	.	+	X	.	.	.					
7	7	O	.	.	.	.	+	X	.	.	.					
8	8	O	.	.	.	.	+	X	.	.	.					
9	2	P	.	.	.	.	+	X	.	.	.					
10	4	P	.	.	.	.	+	X	.	.	.					
11	6	P	.	.	.	.	+	X	.	.	.					
12	8	P	.	.	.	.	+	X	.	.	.					
13	13	O	.	.	.	.	+	X	.	.	.					
14	14	O	.	.	.	.	+	X	.	.	.					
15	15	O	.	.	.	.	+	X	.	.	.					
16	16	O	.	.	.	.	+	X	.	.	.					

▪ Appendix B

**MM-1-4**

```

PORT 1 (SDLC) SUBMENU

1. SDLC OPTIONS

2. MMU PROGRAM

3. COLOR CHECK ENABLE

4. SECONDARY STATIONS/TESTS
    
```

**MM-1-4-1**

```

SDLC PORT 1 CONFIG
      BIU  1  2  3  4  5  6  7  8
TERM & FACILITY . . . . .
DETECTOR RACK  . . . . .

ENABLE TS2/MMU TYPE CABINET..... NO
ENABLE MMU EXTENDED STATUS..... NO
ENABLE SDLC STOP TIME..... NO
ENABLE 3 CRITICAL RFEs LOCKUP..... YES
MMU TO CU SDLC EXTERNAL START... ENABLED
    
```

**MM-1-4-2**

```

MMU PROGRAM [MANUAL]  ERROR
MMU      CH 6 5 4 3 2 1 0 9 8 7 6 5 4 3 2
1 . . . . .
2 . . . . .
3 . . . . .
4 . . . . .
5 . . . . .
6 . . . . .
7 . . . . .
8 . . . . .
9 . . . . .
10 . . . . .
11 . . . . .
12 . . . . .
13 . . . . .
14 . . . . .
15 . . . . .
    
```

**MM-1-4-3**

```

COLOR CHECK ENABLE
ENABLE COLOR CHECK..X

MMU/LS  1 2 3 4 5 6 7 8 9 0 1 2 3 4 5 6
RED      X X X X X X X X X X X X X X X
YELLOW   X X X X X X X X X X X X X X X
GREEN    X X X X X X X X X X X X X X X
    
```

**MM-1-4-4**

```

SECONDARY TO SECONDARY ADDRESSING
T&F 01 02 03 04 05 06 07 08 MMU
. . . . .
D/R 09 10 11 12 13 14 15 16 DIAG
. . . . .
ENABLE SDLC DIAGNOSTIC TEST.....NO
    
```

**MM-1-5**

```

COMMUNICATIONS SUBMENU

1. ETHERNET

2. PORT 2/C50S

3. PORT 3A/C21S

4. PORT 3B/C22S

5. NTCIP

6. ECPPI
    
```

**MM-1-5-1**

```

ETHERNET          MAC FF:FF:FF:FF:FF:FF
CONTROLLER IP..... 255.255.255.255
SUBNET MASK..... 255.255.255.255
DEFAULT GATEWAY IP..... 255.255.255.255
SERVER IP ..... 255.255.255.255
LINK SPEED/DUPLEX..... 1000/FULL
DROP-OUT TIME..... 300

```

**MM-1-5-2, Port 2 on ASC/3 (GPS NMEA)**

```

COMM PORT 2
ENABLE..... NO PROTOCOL      GPS NMEA
BIT RATE.... 4800
D/P/S..... 8/N/1
DUPLEX..... FULL
FLOW CONTROL... YES

```

**MM-1-5-2, Port 2 on ASC/3 (TERM)**

```

COMM PORT 2
ENABLE..... YES PROTOCOL..... TERM
BIT RATE.... 115200
D/P/S..... 8/N/1
DUPLEX..... HALF
FLOW CONTROL... YES

```

**MM-1-5-2, Port 2 on ASC/3 (NTCIP)**

```

COMM PORT 2
ENABLE..... YES PROTOCOL..... NTCIP
BIT RATE.... 115200 ADDRESS..... 65535
D/P/S..... 8/N/1 GROUP ADDRESS. 65535
DUPLEX..... HALF SINGLE FLAGGED.. YES
FLOW CONTROL... YES DROP-OUT TIME. 65535

INTERSECTION MONITOR:
MODEM SETUP STRING..... USER
USER STRING:

```

**MM-1-5-2, Port 2 on ASC/3 (ECPIP)**

```

COMM PORT 2
ENABLE..... YES PROTOCOL..... ECPID
BIT RATE.... 115200 TRD (ms)..... 0.0
D/P/S..... 8/N/1 DROP-OUT TIME. 65535
DUPLEX..... HALF
FLOW CONTROL... YES

```

**MM-1-5-2, Port 2 on ASC/3 (AB3418)**

```

COMM PORT 2
ENABLE..... YES PROTOCOL..... AB3418
BIT RATE.... 115200 ADDRESS..... 65535
D/P/S..... 8/N/1 GROUP ADDRESS. 65535
DUPLEX..... HALF SINGLE FLAGGED.. YES
FLOW CONTROL... YES DROP-OUT TIME. 65535

```

**MM-1-5-2, Port 2 on ASC/3 (METRO RAPID)**

```

COMM PORT 2
ENABLE..... YES PROTOCOL.METRO RAPID
BIT RATE.... 115200 ADDRESS..... 0
D/P/S..... 8/N/1
DUPLEX..... HALF
FLOW CONTROL... YES

```

**MM-1-5-2, Port 2 on ASC/3 (IEEE 1570)**

```

COMM PORT 2
ENABLE..... YES PROTOCOL IEEE 1570
BIT RATE.... 9600 ATCS RAILROAD... 0
D/P/S..... 8/N/1 ATCS RR LINE.... 0
DUPLEX..... HALF ATCS GROUP..... 0
FLOW CONTROL... YES           WAYSIDE ATC
                                DEVICE      0      0
                                SUBNODE    0      0

```

▪ Appendix B

**MM-1-5-2, Port C50S on 2070  
(GPS NMEA)**

```
COMM PORT C50S
ENABLE..... YES PROTOCOL   GPS NMEA
BIT RATE.... 4800
D/P/S..... 8/N/1
DUPLEX..... FULL
```

**MM-1-5-2, Port C50S on 2070 (TERM)**

```
COMM PORT C50S
ENABLE..... YES PROTOCOL..... TERM
BIT RATE.... 38400
D/P/S..... 8/N/1
DUPLEX..... HALF
```

**MM-1-5-2, Port C50S on 2070 (NTCIP)**

```
COMM PORT C50S
ENABLE..... YES PROTOCOL..... NTCIP
BIT RATE.... 38400 ADDRESS..... 65535
D/P/S..... 8/N/1 GROUP ADDRESS. 65535
DUPLEX..... HALF DROP-OUT TIME. 65535
```

**MM-1-5-2, Port C50S on 2070 (AB3418)**

```
COMM PORT C50S
ENABLE..... YES PROTOCOL..... AB3418
BIT RATE.... 38400 ADDRESS..... 65535
D/P/S..... 8/N/1 GROUP ADDRESS. 65535
DUPLEX..... HALF DROP-OUT TIME. 65535
```

**MM-1-5-3, Port 3A on ASC/3  
(GPS NMEA)**

```
COMM PORT 3A
ENABLE..... NO PROTOCOL   GPS NMEA
BIT RATE.... 4800
D/P/S..... 8/N/1
DUPLEX..... FULL
FLOW CONTROL... YES
```

**MM-1-5-3, Port C21S on 2070  
(GPS NMEA)**

```
COMM PORT C21S
ENABLE..... YES PROTOCOL   GPS NMEA
BIT RATE.... 4800
D/P/S..... 8/N/1
DUPLEX..... FULL
```

**MM-1-5-3, Port 3A on ASC/3 (TERM)**

```
COMM PORT 3A
ENABLE..... YES PROTOCOL..... TERM
BIT RATE.... 115200
D/P/S..... 8/N/1
DUPLEX..... HALF
FLOW CONTROL... YES
```

**MM-1-5-3, Port C21S on 2070 (TERM)**

```
COMM PORT C21S
ENABLE..... YES PROTOCOL..... TERM
BIT RATE.... 115200
D/P/S..... 8/N/1
DUPLEX..... HALF
FLOW CONTROL... YES
```

**MM-1-5-3, Port 3A on ASC/3 (NTCIP)**

```

COMM PORT 3A
ENABLE..... YES PROTOCOL..... NTCIP
BIT RATE.... 115200 ADDRESS..... 65535
D/P/S..... 8/N/1 GROUP ADDRESS. 65535
DUPLEX..... HALF SINGLE FLAGGED.. YES
FLOW CONTROL... YES DROP-OUT TIME. 65535
    
```

**MM-1-5-3, Port C21S on 2070 (NTCIP)**

```

COMM PORT C21S
ENABLE..... YES PROTOCOL..... NTCIP
BIT RATE.... 115200 ADDRESS..... 65535
D/P/S..... 8/N/1 GROUP ADDRESS. 65535
DUPLEX..... HALF DROP-OUT TIME. 65535
FLOW CONTROL... YES
    
```

**MM-1-5-3, Port 3A on ASC/3 (ECPIP)**

```

COMM PORT 3A
ENABLE..... YES PROTOCOL..... ECPIP
BIT RATE.... 115200 ADDRESS..... 65535
D/P/S..... 8/N/1 TRD (ms)..... 255
DUPLEX..... HALF DROP-OUT TIME. 65535
FLOW CONTROL... YES
    
```

**MM-1-5-3, Port C21S on 2070 (ECPIP)**

```

COMM PORT C21S
ENABLE..... YES PROTOCOL..... ECPIP
BIT RATE.... 115200 TRD (ms)..... 0.0
D/P/S..... 8/N/1 DROP-OUT TIME. 65535
DUPLEX..... HALF
FLOW CONTROL... YES
    
```

**MM-1-5-3, Port 3A on ASC/3  
(AB3418)**

```

COMM PORT 3A
ENABLE..... YES PROTOCOL..... AB3418
BIT RATE.... 115200 ADDRESS..... 65535
D/P/S..... 8/N/1 GROUP ADDRESS. 65535
DUPLEX..... HALF SINGLE FLAGGED.. YES
FLOW CONTROL... YES DROP-OUT TIME. 65535
    
```

**MM-1-5-3, Port C21S on 2070 (AB3418)**

```

COMM PORT C21S
ENABLE..... YES PROTOCOL..... AB3418
BIT RATE.... 115200 ADDRESS..... 65535
D/P/S..... 8/N/1 GROUP ADDRESS. 65535
DUPLEX..... HALF DROP-OUT TIME. 65535
FLOW CONTROL... YES
    
```

▪ Appendix B

**MM-1-5-4, Port 3B on ASC/3  
(NTCIP)**

```

COMM PORT 3B
ENABLE..... YES PROTOCOL..... NTCIP
BIT RATE.... 115200 ADDRESS..... 65535
D/P/S..... 8/N/1 GROUP ADDRESS. 65535
DUPLEX..... HALF SINGLE FLAGGED.. YES
FLOW CONTROL... YES DROP-OUT TIME. 65535
RTS-CTS DELAY. 6810
RTS TURN OFF.. 6810
EARLY RTS..... YES
    
```

**MM-1-5-4, Port C22S on 2070 (NTCIP)**

```

COMM PORT C22S
ENABLE..... YES PROTOCOL..... NTCIP
BIT RATE.... 115200 ADDRESS..... 65535
D/P/S..... 8/N/1 GROUP ADDRESS. 65535
DUPLEX..... HALF DROP-OUT TIME. 65535
FLOW CONTROL... YES
    
```

**MM-1-5-4, Port 3B on ASC/3  
(ECP/IP)**

```

COMM PORT 3B
ENABLE..... YES PROTOCOL..... ECP/IP
BIT RATE.... 115200 ADDRESS..... 65535
D/P/S..... 8/N/1 TRD (ms)..... 255
DUPLEX..... HALF DROP-OUT TIME. 65535
FLOW CONTROL... YES
RTS-CTS DELAY. 6810
RTS TURN OFF.. 6810
EARLY RTS..... YES
FSK HARDWARE... YES
    
```

**MM-1-5-4, Port C22S on 2070 (ECP/IP)**

(not supported)

**MM-1-5-4, Port 3B on ASC/3  
(TERM)**

```

COMM PORT 3B
ENABLE..... YES PROTOCOL..... TERM
BIT RATE.... 115200
D/P/S..... 8/N/1
DUPLEX..... HALF
FLOW CONTROL... YES
RTS-CTS DELAY. 6810
RTS TURN OFF.. 6810
EARLY RTS..... YES
    
```

**MM-1-5-4, Port C22S on 2070  
(TERM)**

```

COMM PORT C22S
ENABLE..... YES PROTOCOL..... TERM
BIT RATE.... 115200
D/P/S..... 8/N/1
DUPLEX..... HALF
FLOW CONTROL... YES
    
```

**MM-1-5-4, Port 3B on ASC/3  
(AB3418)**

```

COMM PORT 3B
ENABLE..... RS232 PROTOCOL..... AB3418
BIT RATE.... 115200 ADDRESS..... 65535
D/P/S..... 8/N/1 GROUP ADDRESS. 65535
DUPLEX..... HALF SINGLE FLAGGED.. YES
FLOW CONTROL... YES DROP-OUT TIME. 65535
RTS-CTS DELAY. 6810
RTS TURN OFF.. 6810
EARLY RTS..... YES
    
```

**MM-1-5-4, Port C22S on 2070 (AB3418)**

```

COMM PORT C22S
ENABLE..... YES PROTOCOL..... AB3418
BIT RATE.... 115200 ADDRESS..... 65535
D/P/S..... 8/N/1 GROUP ADDRESS. 65535
DUPLEX..... HALF DROP-OUT TIME. 65535
FLOW CONTROL... YES
    
```



**MM-1-5-5 on ASC/3**

```

NTCIP
BACKUP TIME..... 65535
UDP PORT..... 65535
ETHERNET PRIORITY..... 1
PORT 2 PRIORITY..... 4
PORT 3A PRIORITY..... 2
PORT 3B PRIORITY..... 3
    
```

**MM-1-5-5 on 2070**

```

NTCIP
BACKUP TIME..... 65535
UDP PORT..... 65535
ETHERNET PRIORITY..... 1
PORT C50S PRIORITY..... 4
PORT C21S PRIORITY..... 2
PORT C22S PRIORITY..... 3
    
```

**MM-1-5-6 on ASC/3**

```

ECPIP          DAY MM/DD/YYYY|HH:MM:SS
CONTROLLER ADDRESS.....0
EXPANDED SYSTEM DETECTOR ADDRESS.....0

SYSTEM DETECTOR ASSIGNMENT:
SYSTEM DET  1  2  3  4  5  6  7  8
LOCAL DET  64 64 64 64 64 64 64 64
SYSTEM DET  9 10 11 12 13 14 15 16
LOCAL DET  64 64 64 64 64 64 64 64
    
```

**MM-1-5-6 on 2070**

RESERVED

**MM-1-6-1**

```

EVENT LOGGING
RFEs (MMU/TF).. YES 3 RFes >24H.... YES
MMU FL FAULTS.. YES LOCAL FLASH.... YES
RFes (DET/TEST) YES DETECTOR ERRORS. YES
COORD ERRORS... YES CTR DOWNLOAD.... YES
PREEMPT..... YES TSP..... YES
POWER ON/OFF... YES LOW BATTERY.... YES
ACCESS..... YES DATA CHANGE.... YES
ONLINE/OFFLINE. YES
ALARM 1..... YES ALARM 2..... YES
ALARM 3..... YES ALARM 4..... YES
ALARM 5..... YES ALARM 6..... YES
ALARM 7..... YES ALARM 8..... YES
ALARM 9..... YES ALARM 10..... YES
ALARM 11..... YES ALARM 12..... YES
ALARM 13..... YES ALARM 14..... YES
ALARM 15..... YES ALARM 16..... YES
    
```

**MM-1-7**

```

DISPLAY/ACCESS SUBMENU

1. ADMINISTRATION
2. DISPLAY OPTIONS
3. SECURITY ACCESS
    
```

▪ Appendix B

**MM-1-7-1**

```

ADMINISTRATION

ENABLE CU/CABINET INTERLOCK CRC.... NO
CU/CABINET INTERLOCK CRC VALUE..... 0000
CU/CABINET INTERLOCK HW VALUE..... 0000

REQUEST DOWNLOAD CONTROLLER DATA... NO
CONTROLLER DATABASE CRC ..... C2C5
ENABLE AUTOMATIC BACKUP TO DATAKEY. NO
    
```

**MM-1-7-2**

```

DISPLAY OPTIONS
KEY CLICK ENABLE..... YES

BACKLIGHT ENABLE..... YES

LED MODE..... AUTO

MAIN STATUS DISPLAY MODE..... ADVANCED

SCREEN FORMAT..... ADVANCED
    
```

**MM-1-7-3**

```

SECURITY ACCESS -SELECT NAME-
01 administrator-- 02 L TA-----
03 B HELLIAR----- 04 D MCNULTY-----
05 G MEREDITH----- 06 J PASTRANO-----
07 L LINDLEY----- 08 L MAGASWERAN---
09 M PHAM----- 10 P HOLLINGSWORTH
11 public----- 12 public-----
13 public----- 14 public-----
15 public----- 16 public-----
17 public----- 18 public-----
19 public----- 20 public-----
21 public----- 22 public-----
23 public----- 24 public-----
25 public----- 26 public-----
27 public----- 28 public-----
29 public----- 30 public-----
// //
49 public----- 50 public-----
    
```

**MM-1-7-3, User Security Change**

```

USER ACCOUNT 2

CURRENT CHANGE
NAME L TA L TA
ACCESS READ-ONLY READ-WRITE

ACCESS CODE ***** 0

ACCESS CODE CONFIRM 0

1 2 3 4 5 6 7 8 9
SPACE ABC DEF GHI JKL MNO PQRS TUV WXYZ
    
```

**MM-1-8**

```

LOGIC PROCESSOR SUBMENU

1. LOGIC STATEMENT CONTROL

2. LOGIC STATEMENTS
    
```

**MM-1-8-1**

```

LOGIC STATEMENT CONTROL
1 2 3 4 5 6 7 8 9 0 1 2 3 4 5
LP 1-15. . . . .
LP 16-30. . . . .
LP 31-45. . . . .
LP 46-60. . . . .
LP 61-75. . . . .
LP 76-90. . . . .
LP 91-100. . . . .

D = DISABLED E = ENABLED
"." = ENABLED / DISABLED BY OTHER SOURCE
    
```

**MM-1-8-2**

```

LOGIC # 98      ACTIVE: N

IF  GREEN ON PHASE      10 IS ON
AND VEHICLE DET #      1 IS ON
OR  MINGRN TMR ON PHASE 10 < 15.7

THEN SET VEHICLE DET #  1    OFF
     SET GREEN OVERLAP  B    OFF
     SET YELLOW OVERLAP B    ON

ELSE DELAY FOR          15.7 SECONDS
     SET VEHICLE DET #  1    ON
    
```

**MM-2**

```

CONTROLLER SUBMENU

1. TIMING PLANS          5. START/FLASH
2. VEHICLE OVERLAPS     6. OPTION DATA
3. VEH/PED OVERLAPS    7. PRE-TIMED
4. GUAR MIN TIME       8. PHASE RECALL
    
```

**MM-2-1**

```

TIMING PLAN [ 1 ] PHASE DATA
PHASE.....1...2...3...4...5...6...7...8...9...10...11...12...13...14...15...16
MIN GRN    5  5  5  5  5  5  5  5  5  5  5  5  5  5  5  5
BK MGRN    0  0  0  0  0  0  0  0  0  0  0  0  0  0  0  0
CS MGRN    0  0  0  0  0  0  0  0  0  0  0  0  0  0  0  0
DLY GRN    0  0  0  0  0  0  0  0  0  0  0  0  0  0  0  0
WALK       0  0  0  0  0  0  0  0  0  0  0  0  0  0  0  0
WALK2      0  0  0  0  0  0  0  0  0  0  0  0  0  0  0  0
WLK MAX    0  0  0  0  0  0  0  0  0  0  0  0  0  0  0  0
PED CLR    0  0  0  0  0  0  0  0  0  0  0  0  0  0  0  0
PD CLR2    0  0  0  0  0  0  0  0  0  0  0  0  0  0  0  0
PC MAX     0  0  0  0  0  0  0  0  0  0  0  0  0  0  0  0
PED CO     0  0  0  0  0  0  0  0  0  0  0  0  0  0  0  0
VEH EXT    0.0 0.0 0.0 0.0 0.0 0.0 0.0 0.0 0.0 0.0 0.0 0.0 0.0 0.0 0.0 0.0
VH EXT2    0.0 0.0 0.0 0.0 0.0 0.0 0.0 0.0 0.0 0.0 0.0 0.0 0.0 0.0 0.0 0.0
MAX 1      35 35 35 35 35 35 35 35 35 35 35 35 35 35 35 35
MAX 2      35 35 35 35 35 35 35 35 35 35 35 35 35 35 35 35
MAX 3      35 35 35 35 35 35 35 35 35 35 35 35 35 35 35 35
DYM MAX    0  0  0  0  0  0  0  0  0  0  0  0  0  0  0  0
DYM STP    0  0  0  0  0  0  0  0  0  0  0  0  0  0  0  0
YELLOW     0.0 0.0 0.0 0.0 0.0 0.0 0.0 0.0 0.0 0.0 0.0 0.0 0.0 0.0 0.0 0.0
RED CLR    0.0 0.0 0.0 0.0 0.0 0.0 0.0 0.0 0.0 0.0 0.0 0.0 0.0 0.0 0.0 0.0
RED MAX    0.0 0.0 0.0 0.0 0.0 0.0 0.0 0.0 0.0 0.0 0.0 0.0 0.0 0.0 0.0 0.0
RED RVT    0.0 0.0 0.0 0.0 0.0 0.0 0.0 0.0 0.0 0.0 0.0 0.0 0.0 0.0 0.0 0.0
ACT B4     0  0  0  0  0  0  0  0  0  0  0  0  0  0  0  0
SEC/ACT    0.0 0.0 0.0 0.0 0.0 0.0 0.0 0.0 0.0 0.0 0.0 0.0 0.0 0.0 0.0 0.0
MAX INT    0  0  0  0  0  0  0  0  0  0  0  0  0  0  0  0
TIME B4    0  0  0  0  0  0  0  0  0  0  0  0  0  0  0  0
CARS WT    0  0  0  0  0  0  0  0  0  0  0  0  0  0  0  0
STPTDUC    0.0 0.0 0.0 0.0 0.0 0.0 0.0 0.0 0.0 0.0 0.0 0.0 0.0 0.0 0.0 0.0
TTREDUC    0  0  0  0  0  0  0  0  0  0  0  0  0  0  0  0
MIN GAP    0.0 0.0 0.0 0.0 0.0 0.0 0.0 0.0 0.0 0.0 0.0 0.0 0.0 0.0 0.0 0.0
    
```

▪ Appendix B

**MM-2-2 (TYPE: OTHER/ECONOLITE)**

```

TMG VEH OVLP...[A] TYPE:OTHER/ECONOLITE
  PHASES 1 2 3 4 5 6 7 8 9 0 1 2 3 4 5 6
INCLUDED . . . . . X . . . . .
PROTECT . . . . .
PED PRTC . . . . .
NOT OVLP . . . . .
FLSH GRN . . . . .
LAG X PH . . . . .
LAG 2 PH . . . . .

LAG GRN 0.0 YEL 0.0 RED 0.0 ADV GRN 0.0
    
```

**MM-2-2 (TYPE: NORMAL)**

```

TMG VEH OVLP...[A] TYPE: . . . . .NORMAL
  PHASES 1 2 3 4 5 6 7 8 9 0 1 2 3 4 5 6
INCLUDED . . . . . X . . . . .

LAG GRN 0.0 YEL 0.0 RED 0.0
    
```

**MM-2-2 (TYPE: -GRN/YEL)**

```

TMG VEH OVLP...[A] TYPE: . . . . .-GRN/YEL
  PHASES 1 2 3 4 5 6 7 8 9 0 1 2 3 4 5 6
INCLUDED . . . . . X . . . . .
MODIFIER . . . . .
    
```

**MM-2-2 (TYPE: PPLT FYA)**

```

TMG VEH OVLP...[A] TYPE: . . . . .PPLT FYA

PROTECTED PHASE (LEFT TURN) . . . . . 0
PERMISSIVE PHASE (OPPOSING THRU) . . . . 0
FLASHING ARROW OUTPUT . . . . .CH 0 GRN OLP

DELAY START OF: FYA . . . . .0.0 CLEARANCE . . . . .0.0
ACTION PLAN SF BIT DISABLE . . . . . 0
    
```

**MM-2-3**

VEH/PED OVERLAPS																
INCLUDED	1	2	3	4	5	6	7	8	9	0	1	2	3	4	5	6
VEH OL A	.	.	.	.	.	.	.	.	.	.	.	.	.	.	.	.
VEH OL B	.	.	.	.	.	.	.	.	.	.	.	.	.	.	.	.
VEH OL C	.	.	.	.	.	.	.	.	.	.	.	.	.	.	.	.
VEH OL D	.	.	.	.	.	.	.	.	.	.	.	.	.	.	.	.
VEH OL E	.	.	.	.	.	.	.	.	.	.	.	.	.	.	.	.
VEH OL F	.	.	.	.	.	.	.	.	.	.	.	.	.	.	.	.
VEH OL G	.	.	.	.	.	.	.	.	.	.	.	.	.	.	.	.
VEH OL H	.	.	.	.	.	.	.	.	.	.	.	.	.	.	.	.
VEH OL I	.	.	.	.	.	.	.	.	.	.	.	.	.	.	.	.
VEH OL J	.	.	.	.	.	.	.	.	.	.	.	.	.	.	.	.
VEH OL K	.	.	.	.	.	.	.	.	.	.	.	.	.	.	.	.
VEH OL L	.	.	.	.	.	.	.	.	.	.	.	.	.	.	.	.
VEH OL M	.	.	.	.	.	.	.	.	.	.	.	.	.	.	.	.
VEH OL N	.	.	.	.	.	.	.	.	.	.	.	.	.	.	.	.
VEH/PED OVERLAPS																
INCLUDED	1	2	3	4	5	6	7	8	9	0	1	2	3	4	5	6
VEH OL O	.	.	.	.	.	.	.	.	.	.	.	.	.	.	.	.
VEH OL P	.	.	.	.	.	.	.	.	.	.	.	.	.	.	.	.
PD OL 01	.	.	.	.	.	.	.	.	.	.	.	.	.	.	.	.
PD OL 02	.	.	.	.	.	.	.	.	.	.	.	.	.	.	.	.
PD OL 03	.	.	.	.	.	.	.	.	.	.	.	.	.	.	.	.
PD OL 04	.	.	.	.	.	.	.	.	.	.	.	.	.	.	.	.
PD OL 05	.	.	.	.	.	.	.	.	.	.	.	.	.	.	.	.
PD OL 06	.	.	.	.	.	.	.	.	.	.	.	.	.	.	.	.
PD OL 07	.	.	.	.	.	.	.	.	.	.	.	.	.	.	.	.
PD OL 08	.	.	.	.	.	.	.	.	.	.	.	.	.	.	.	.
PD OL 09	.	.	.	.	.	.	.	.	.	.	.	.	.	.	.	.
PD OL 10	.	.	.	.	.	.	.	.	.	.	.	.	.	.	.	.
PD OL 11	.	.	.	.	.	.	.	.	.	.	.	.	.	.	.	.
PD OL 12	.	.	.	.	.	.	.	.	.	.	.	.	.	.	.	.
VEH/PED OVERLAPS																
INCLUDED	1	2	3	4	5	6	7	8	9	0	1	2	3	4	5	6
PD OL 13	.	.	.	.	.	.	.	.	.	.	.	.	.	.	.	.
PD OL 14	.	.	.	.	.	.	.	.	.	.	.	.	.	.	.	.
PD OL 15	.	.	.	.	.	.	.	.	.	.	.	.	.	.	.	.
PD OL 16	.	.	.	.	.	.	.	.	.	.	.	.	.	.	.	.

**MM-2-4**

GUARANTEED MINIMUM TIME DATA									
PHASE	A01	B02	C03	D04	E05	F06	G07	H08	
MIN GRN	5	5	5	5	5	5	5	5	5
WALK	0	0	0	0	0	0	0	0	0
PED CLR	7	7	7	7	7	7	7	7	7
YELLOW	3.0	3.0	3.0	3.0	3.0	3.0	3.0	3.0	3.0
RED CLR	0.0	0.0	0.0	0.0	0.0	0.0	0.0	0.0	0.0
OVL GRN	5	5	5	5	5	5	5	5	5
PHASE	I09	J10	K11	L12	M13	N14	O15	P16	
MIN GRN	5	5	5	5	5	5	5	5	5
WALK	0	0	0	0	0	0	0	0	0
PED CLR	7	7	7	7	7	7	7	7	7
YELLOW	3.0	3.0	3.0	3.0	3.0	3.0	3.0	3.0	3.0
RED CLR	0.0	0.0	0.0	0.0	0.0	0.0	0.0	0.0	0.0
OVL GRN	5	5	5	5	5	5	5	5	5

▪ Appendix B

**MM-2-5**

```

START/FLASH DATA
-----START UP-----
      1 2 3 4 5 6 7 8 9 0 1 2 3 4 5 6
PHASE  R R R R R R R R R R R R R R R R
      A B C D E F G H I J K L M N O P
OVERLAP X X X X . . . . .
FLASH>MON. NO FL TIME..255 ALL RED... 6
PWR START SEQ.. 1 MUTCD->YES Y->G: NO
-----AUTOMATIC FLASH-----
      PHASE 1 2 3 4 5 6 7 8 9 0 1 2 3 4 5 6
ENTRY   . X . . . X . . . . .
EXIT    . X . . . X . . . . .
OVERLAP A B C D E F G H I J K L M N O P
EXIT    X X X X . . . . .
FLASH>MON. NO EXIT FL. W MIN FLASH. 8
MINIMUM RECALL. NO CYCLE THRU PHASE. NO
    
```

**MM-2-6**

```

OPTION DATA SUBMENU

1. CONTROLLER OPTIONS

2. EXTENDED OPTIONS
    
```

**MM-2-6-1**

```

CONTROLLER OPTIONS
PED CLEAR PROTECT . UNIT RED REVERT 2.0
MUTCD 3 SECONDS DONT WALK ..... NO
      PHASE 1 2 3 4 5 6 7 8 9 10 11 12 13 14 15 16
FLASHING GRN PH. . . . .
GUAR PASSAGE.... . . . .
NON-ACT I..... . . . .
NON-ACT II..... . . . .
DUAL ENTRY..... . . . .
COND SERVICE.... . . . .
COND RESERVICE.. . . . .
PED RESERVICE... . . . .
REST IN WALK.... . . . .
FLASHING WALK... . . . .
PED CLR>YELLOW.. . . . .
PED CLR>RED..... . . . .
IGRN + VEH EXT.. . . . .
    
```

**MM-2-6-2**

```

EXTENDED OPTIONS

IDOT 5 SECTION HEAD CONTROL.....ON
LP FEATURE.....OFF
CANADIAN LEFT TURN.....OFF
    
```

**MM-2-7**

```

PRE-TIMED MODE

ENABLE PRE-TIMED MODE..... NO
FREE INPUT ENABLES PRE-TIMED..... YES
      PHASE 1 2 3 4 5 6 7 8 9 0 1 2 3 4 5 6
PRETIMED . . . . .
    
```

**MM-2-8**

```
PHASE RECALL OPTIONS
TIMING PLAN NUMBER [ 1 ]
  PHASE.. 1 2 3 4 5 6 7 8 9 0 1 2 3 4 5 6
LOCK DET X X X X X X X X X X X X X X X X
VE RCALL . . . . .
PD RCALL . . . . .
MX RCALL . . . . .
SF RCALL . . . . .
NO REST . . . . .
AI CALC . . . . .
```

**MM-3**

```
COORDINATOR SUBMENU

1. COORDINATOR OPTIONS
2. COORDINATOR PATTERNS
3. SPLIT PATTERNS
4. AUTO PERM MIN GREEN
5. SPLIT DEMAND
```

**MM-3-1**

```

COORD OPTIONS
MANUAL PATTERN... 1 ECPI COORD.....YES
SYSTEM SOURCE.. TBC SYSTEM FORMAT.. STD
SPLITS IN...SECONDS OFFSET IN...SECONDS
TRANSITION.. ADDONLY MAX SELECT. MAXINH
DWELL/ADD TIME... 0 ENABLE MAN SYNC. NO
DLY COORD WK-LZ. NO FORCE OFF... FIXED
OFFSET REF.... LEAD CAL USE PED TM..YES
PED RECALL..... NO PED RESERVE..... NO
LOCAL ZERO OVRD.. NO FO ADD INI GRN.. NO
RE-SYNC COUNT.... 0 MULTISYNC..... NO
    
```

**MM-3-2**

```

COORDINATOR PATTERN [ 1]
USE SPLIT PATTERN. 1 SPLIT SUM .....0s
TS2 (PAT-OFF).. 0-1
CYCLE..... 100s STD (COS).....111
OFFSET VAL..... 0s DWELL/ADD TIME. 0
ACTUATED COORD... NO TIMING PLAN.... 0
ACT WALK REST.... NO SEQUENCE..... 0
PHASE RESRVCE.... NO ACTION PLAN.... 0
MAX SELECT..... NONE FORCE OFF.... NONE
SPLIT PREFERENCE PHASES
  PHASE[s] 1 2 3 4 5 6 7 8
SPT[ 1] 0 0 0 0 0 0 0 0
PREF 1... 0 0 0 0 0 0 0 0
PREF 2... 0 0 0 0 0 0 0 0
SPLT EXT. 0 0 0 0
VEH PERM. 0 0 0 DISP
RING DISP - 0 0 0 (RING 2-4)
  PHASE[s] 9 10 11 12 13 14 15 16
SPT[ 1] 0 0 0 0 0 0 0 0
PREF 1... 0 0 0 0 0 0 0 0
PREF 2... 0 0 0 0 0 0 0 0

          1 2
SPLIT DEMAND PTRN. xxx xxx XART PTRN. xxx
PHASE.. 1 2 3 4 5 6 7 8 9 0 1 2 3 4 5 6
COORD... . . . . .
VE RCALL . . . . .
PD RCALL . . . . .
MX RCALL . . . . .
OMIT.... . . . . .
SF OUT.. . . . . (1-8)
    
```

**MM-3-3**

```

SPLIT PATTERN [ 1]

  PHASE[s] 1 2 3 4 5 6 7 8
SPLIT      0 0 0 0 0 0 0 0

  PHASE[s] 9 10 11 12 13 14 15 16
SPLIT      0 0 0 0 0 0 0 0

PHASE.. 1 2 3 4 5 6 7 8 9 0 1 2 3 4 5 6
COORD... . . . . .
VE RCALL . . . . .
PD RCALL . . . . .
MX RCALL . . . . .
OMIT.... . . . . .
    
```

**MM-3-4**

```

AUTO PERM MINIMUM GREEN (SECONDS)

  PHASE 1 2 3 4 5 6 7 8
MIN GRN. 0 0 0 0 0 0 0 0

  PHASE 9 10 11 12 13 14 15 16
MIN GRN. 0 0 0 0 0 0 0 0
    
```



**MM-3-5**

```

SPLIT DEMAND
  PHASES 1 2 3 4 5 6 7 8 9 0 1 2 3 4 5 6
DEMAND 1 . . . . .
DEMAND 2 . . . . .
      DEMAND 1 2
DETECTOR..... 0 0
CALL TIME (SEC).. 0 0
CYCLE COUNT..... 0 0
    
```

**MM-4**

```

PREEMPT/TSP/SCP SUBMENU

1. PREEMPT PLAN 1-10

2. ENABLE PREEMPT FILTERING & TSP/SCP

3. TSP/SCP PLAN 1-6

4. TSP/SCP SPLIT PATTERN
    
```

**MM-4-1**

```

PREEMPT PLAN [ 1]  ENABLE.... NO
VEH/PED 1 2 3 4 5 6 7 8 9 0 1 2 3 4 5 6
OVERLAP A B C D E F G H I J K L M N O P
TRKCLR V . . . . .
TRKCLR O . . . . .
ENA TRL . . . . .
DWEL VEH . . . . .
DWEL PED . . . . .
DWEL OLP . . . . .
CYC VEH . . . . .
CYC PED . . . . .
CYC OLP . . . . .
EXIT PH . . . . .
EXIT CAL . . . . .
SP FUNC . . . . . (1-8)
    
```

**MM-4-2**

```

ENABLE PREEMPT FILTERING & TSP/SCP
FILTERED      SOLID      PULSING
INPUT 1 ...BYPASSED... ..BYPASSED..
2 ...BYPASSED... ..BYPASSED..
3 ..PREEMPT 3. ..PREEMPT 7.
4 ..PREEMPT 4. ..PREEMPT 8.
5 ..PREEMPT 5. ..PREEMPT 9.
6 ..PREEMPT 6. ..PREEMPT 10.
7 ...BYPASSED... ..BYPASSED..
8 ...BYPASSED... ..BYPASSED..
9 ...BYPASSED... ..BYPASSED..
10 ...BYPASSED... ..BYPASSED..
    
```

```

PREEMPT PLAN [ 1]  ENABLE.... NO
ENABLE.... NO|PMT OVRIDE.X|INTERLOCK NO
DET LOCK.. X|DELAY.. 0|INHIBIT... 0
OVERIDE FL. .|DURATION 0|CLR>GRN... NO
TERM OLP.ASAP|PC>YEL  NO|TERM PH  NO
PED DARK.. NO|TC RESRV. NO|DWELL FL LDSW
LINK PMT...0|X FLCOLR GRN|EXIT OPT. OFF
X TMG PLN...0|RE-SERV.. 0|FLT TYPE HARD
FREE DUR PMT|R1 NO|R2 NO|R3 NO|R4 NO
--TIMING----WALK|PED CL|MN GR| YEL| RED
ENTRANCE TM. 0| 255| 5| 4.0| 1.0
-----MIN GR|EXT GR|MX GR| YEL| RED
TRACK CLEAR 0| 255| 5| 4.0| 1.0
-----MIN DL|PMTEXT|MX TM| YEL| RED
DWL/CYC-EXIT 0| 0.0| 0| 4.0| 1.0
PMT ACTIVE OUT.. ON PMT ACT DWELL... NO
OTHER - PRI PMT.OFF NON-PRI PMT....OFF
INH EXT TIME...25.5 PED PR RETURN...OFF
PRIORITY RETURN.OFF QUEUE DELAY.... OFF
COND DELAY.....OFF
PHASES      1 2 3 4 5 6 7 8
PR RTN%     0 0 0 0 0 0 0 0
PHASES      9 10 11 12 13 14 15 16
PR RTN%     0 0 0 0 0 0 0 0
    
```

▪ Appendix B

**MM-4-3**

```

TSP/SCP PLAN
  TSP/SCP PLAN      1  2  3  4  5  6
TSP/SCP ENA        T1 T2  .  .  .  .
SIGNAL TYPE        P  P  P  P  P  P
DET LOCK           .  .  .  .  .  .
DELAY TIME          XXX XXX XXX XXX XXX XXX
MAX PRESENCE        0  0  0  0  0  0
PMT ENA RESERVE    X  X  X  X  X  X
NO DELAY IN TSP    X  X  X  X  X  X
ACT SF INHIBIT     0  0  0  0  0  0
RESERVE CYCLS      0  0  0  0  0  0
BUS HEADING         NB SB  EB  WB
TSP OR SCP... TSP FREE DEFAULT PLAN.120
HEADWAY ALLOWANCE 100%

----- TSP/SCP PHASE -----
  1 2 3 4 5 6 7 8 9 0 1 2 3 4 5 6
TSP/SCP1 . T . P . T . P . . . . .
TSP/SCP2 . . V T . . V T . . . . .
TSP/SCP3 . . . . . . . . . . .
TSP/SCP4 . . . . . . . . . . .
TSP/SCP5 . . . . . . . . . . .
TSP/SCP6 . . . . . . . . . . .
    
```

**MM-4-4**

```

TSP/SCP SPLIT PATTERN [ 1 ]
IN EFFECT TMG PLAN [1] 0 SPL DM [0] 0
  PHASE   1  2  3  4  5  6  7  8
MAX RDTN.255 255 255 255 255 255 255 255
MIN GRN..  5  5  5  5  5  5  5  5
MAX EXTN.255 255 255 255 255 255 255 255

  PHASE   9 10 11 12 13 14 15 16
MAX RDTN.255 255 255 255 255 255 255 255
MIN GRN..  5  5  5  5  5  5  5  5
MAX EXTN.255 255 255 255 255 255 255 255
    
```

**MM-5**

```

TIME BASE SUBMENU

1. CLOCK/CALENDAR DATA

2. ACTION PLAN

3. DAY PLAN/EVENT

4. SCHEDULE NUMBER

5. EXCEPTION DAYS
    
```

**MM-5-1**

```

CLOCK/CALENDAR DATA
MM/DD/YYYY          DAY      HH:MM:SS
ENA ACTION PLAN.  0
SYNC REF TIME.00:00 SYNC REF.. REF TIME
TIME FROM GMT...-04 DAY LIGHT SAVE.USDLS
TIME RESET INPUT SET TIME..... 03:30:00
    
```

**MM-5-2**

```

ACTION PLAN...[ 1]
PATTERN.....AUTC SYS OVERRIDE....YES
TIMING PLAN..... 0 SEQUENCE..... 0
VEH DETECTOR PLAN.. 0 DET LOG.....NONE
FLASH..... EN RED REST.....YES
VEH DET DIAG PLN.. 0 PED DET DIAG PLN..0
DIMMING ENABLE.. NO

    PHASE 1 2 3 4 5 6 7 8 9 0 1 2 3 4 5 6
PED RCL . . . . .
WALK 2 . . . . .
VEX 2 . . . . .
VEH RCL . . . . .
MAX RCL . . . . .
MAX 2 . X X X X X X X X . . . . .
MAX 3 . . . . .
CS INH . . . . .
OMIT . . . . .
SPC FCT . . . . . (1-8)
AUX FCT . . . (1-3)
    1 2 3 4 5 6 7 8 9 0 1 2 3 4 5
LP 1-15 . . . . .
LP 16-30 . . . . .
LP 31-45 . . . . .
LP 46-60 . . . . .
LP 61-75 . . . . .
LP 76-90 . . . . .
LP91-100 . . . . .
    
```

**MM-5-3**

DAY PLAN [ 1]	DAY PLAN IN EFFECT [ 0] v
EVENT	ACTION PLAN START TIME
1	0 00:00
2	0 00:00
3	0 00:00
4	0 00:00
5	0 00:00
6	0 00:00
7	0 00:00
8	0 00:00
9	0 00:00
10	0 00:00
11	0 00:00
12	0 00:00
13	0 00:00
14	0 00:00

DAY PLAN [ 1]	DAY PLAN IN EFFECT [ 0] ^v
EVENT	ACTION PLAN START TIME
15	0 00:00
16	0 00:00
17	0 00:00
18	0 00:00
19	0 00:00
20	0 00:00
21	0 00:00
22	0 00:00
23	0 00:00
24	0 00:00
25	0 00:00
26	0 00:00
//	
50	0 00:00

**MM-5-4**

```

SCHEDULE NUMBER [ 1]
DAY PLAN NO . . . . 0 CLEAR ALL FIELDS.. X
SELECT ALL MONTHS.. . DOW.. . DOM.. .
MONTH      J F M A M J J A S O N D
. . . . .
DAY (DOW) : SUN MON TUE WED THU FRI SAT
. . . . .
DAY (DOM) : 1  2  3  4  5  6  7  8  9 10 11
. . . . .
          12 13 14 15 16 17 18 19 20 21 22
. . . . .
          23 24 25 26 27 28 29 30 31
. . . . .
    
```

**MM-5-5**

EXCEPTION DAY PROGRAM	DAY	FLOAT/FIXED	MON/MON	DOW/DOM	WOM/YEAR	DAY PLAN
	1	FIXED	0	0	0	0
	2	FIXED	0	0	0	0
	3	FIXED	0	0	0	0
	4	FIXED	0	0	0	0
	5	FIXED	0	0	0	0
	6	FIXED	0	0	0	0
	7	FIXED	0	0	0	0
	8	FIXED	0	0	0	0
	9	FIXED	0	0	0	0
	10	FIXED	0	0	0	0
	11	FIXED	0	0	0	0
	12	FIXED	0	0	0	0
	13	FIXED	0	0	0	0

EXCEPTION DAY PROGRAM	DAY	FLOAT/FIXED	MON/MON	DOW/DOM	WOM/YEAR	DAY PLAN
	//					
	36	FIXED	0	0	0	0

**MM-6**

- DETECTOR SUBMENU

  1. VEH DET PHASE ASSIGNMENT
  2. VEHICLE DETECTOR SETUP
  3. PED DETECTOR INPUT ASSIGNMENT
  4. LOG INT / SPEED DETECTOR SETUP
  5. VEHICLE DETECTOR DIAGNOSTICS
  6. PEDESTRIAN DETECTOR DIAGNOSTICS

**MM-6-1**

VEH DET PH ASSIGN	VEH DET PLAN [ 1 ]	> v
[	ADDITIONAL PHASE CALLS	]
DET PH	1 2 3 4 5 6 7 8 9 0 1 2 3 4 5 6	T-TYPE
1	1 . . . . .	S-STANDARD
2	2 . . . . .	D-DISCONNECT TYPE QUEUE/STOP BAR
3	3 . . . . .	P-PASSAGE TYPE QUEUE/STOP BAR
4	4 . . . . .	C-CALLING
5	5 . . . . .	R-RED EXTENSION
6	6 . . . . .	G-GREEN EXTENSION/DELAY
7	7 . . . . .	N-NTCIP
8	8 . . . . .	B-BIKE
9	9 . . . . .	S-STANDARD
10	10 . . . . .	S-STANDARD
11	11 . . . . .	S-STANDARD
12	12 . . . . .	S-STANDARD
13	13 . . . . .	S-STANDARD
14	14 . . . . .	S-STANDARD
15	15 . . . . .	S-STANDARD
16	16 . . . . .	S-STANDARD
17	0 . . . . .	S-STANDARD
18	0 . . . . .	S-STANDARD
19	0 . . . . .	S-STANDARD
20	0 . . . . .	S-STANDARD
21	0 . . . . .	S-STANDARD
22	0 . . . . .	S-STANDARD
23	0 . . . . .	S-STANDARD
24	0 . . . . .	S-STANDARD
25	0 . . . . .	S-STANDARD
26	0 . . . . .	S-STANDARD
27	0 . . . . .	S-STANDARD
//		
64	0 . . . . .	S-STANDARD

**MM-6-2 (STANDARD)**

```

VEH DETECTOR [ 1]   VEH DET PLAN [ 1]
TYPE: S-STANDARD
TS2 DETECTOR..... X ECPI LOG..... YES
DET PH - 1 2 3 4 5 6 7 8 9 0 1 2 3 4 5 6
  1 1 . . . . .
EXTEND TIME... 0.0 DELAY TIME... 0.0
USE ADDED INITIAL . CROSS SWITCH PH.. 0
LOCK IN..... YELLOW NTCIP VOL X OR OCC X
PMT QUEUE DELAY. NO

```

**MM-6-2 (DISCONNECT)**

```

VEH DETECTOR [ 1]   VEH DET PLAN [ 1]
TYPE: D-DISCONNECT TYPE QUEUE/STOP BAR
TS2 DETECTOR..... X ECPI LOG..... NO
DISCONNECT TIME..... 0
USE ADDED INITIAL . CROSS SWITCH PH.. 0
LOCK IN..... NONE NTCIP VOL X OR OCC X
PMT QUEUE DELAY. NO

```

**MM-6-2 (PASSAGE QUEUE)**

```

VEH DETECTOR [ 1]   VEH DET PLAN [ 1]
TYPE: P-PASSAGE TYPE QUEUE/STOP BAR
TS2 DETECTOR..... X ECPI LOG..... NO
PASSAGE TIME..... 0.0
USE ADDED INITIAL . CROSS SWITCH PH.. 0
LOCK IN..... NONE NTCIP VOL X OR OCC X
PMT QUEUE DELAY. NO

```

**MM-6-2 (CALLING)**

```

VEH DETECTOR [ 1]   VEH DET PLAN [ 1]
TYPE: C-CALLING
TS2 DETECTOR..... X ECPI LOG..... NO
USE ADDED INITIAL . CROSS SWITCH PH.. 0
LOCK IN..... NONE NTCIP VOL X OR OCC X
PMT QUEUE DELAY. NO

```

**MM-6-2 (RED EXTENSION)**

```

VEH DETECTOR [ 1]   VEH DET PLAN [ 1]
TYPE: R-RED EXTENSION
TS2 DETECTOR..... X ECPI LOG..... NO

```

**MM-6-2 (GREEN EXTENSION)**

```

VEH DETECTOR [ 1]   VEH DET PLAN [ 1]
TYPE: G-GREEN EXTENSION/DELAY
TS2 DETECTOR..... X ECPI LOG..... NO
EXTEND TIME... 0.0 DELAY TIME... 0.0
USE ADDED INITIAL . CROSS SWITCH PH.. 0
LOCK IN..... NONE NTCIP VOL X OR OCC X
PMT QUEUE DELAY. NO

```

**MM-6-2 (NTCIP)**

```

VEH DETECTOR [ 1]   VEH DET PLAN [ 1]
TYPE: N-NTCIP
TS2 DETECTOR..... X ECPI LOG..... NO
CALL OPTION... YES DELAY TIME... 0.0
EXT OPTION. PASSAGE EXTENSION TIME. 0.0
USE ADDED INITIAL . CROSS SWITCH PH.. 0
LOCK IN..... NONE NTCIP VOL X OR OCC X
PMT QUEUE DELAY. NO

```

**MM-6-2 (BIKE)**

```

VEH DETECTOR [ 1]   VEH DET PLAN [ 1]
TYPE: B-BIKE
TS2 DETECTOR..... X ECPI LOG..... NO
EXTEND TIME... 0.0 NTCIP VOL X OR OCC X

```

▪ Appendix B

**MM-6-3 (NTCIP MODE)**

```

PED DET PHASE ASSIGNMENT MODE: NTCIP

  PHASE  1   2   3   4   5   6   7   8
DETECTOR 1   2   3   .   .   .   5   .

  PHASE  9  10  11  12  13  14  15  16
DETECTOR 10  .   .   .   .   .   .   .
    
```

**MM-6-3 (ECONOLITE MODE)**

```

PED DET PHASE ASSIGNMENT MODE:ECONOLITEv
PHASE  1 2 3 4 5 6 7 8 9 0 1 2 3 4 5 6
D  1 X . . . . . . . . . . . . . . .
E  2 . X . . . . . . . . . . . . . . .
T  3 . . . . . . . . . . . . . . . . .
E  4 . . . . B . . . . . . . . . . . .
C  5 . . . . . . . . . . . . . . . . .
T  6 . . . . . . . . 2 . . . . . . . . .
O  7 . . . . . . . . . . . . . . . . .
R  8 . . . . . . . . . . . . . . . . .
  9 . . . . . . . . . . . . . . . . .
10 . . . . . . . . . X . . . . . . . . .
11 . . . . . . . . . . . . . . . . .
12 . . . . . . . . . . . . . . . . .
13 . . . . . . . . . . . . . . . . .
14 . . . . . . . . . . . . . . . . .
15 . . . . . . . . . . . . . . . . .
16 . . . . . . . . . . . . . . . . .
    
```

**MM-6-4**

```

LOG - SPEED DETECTOR SETUP
NTCIP LOG.  0 ECPI LOG.  TBAP LENGTH.INCH
  SPEED DET  1  2  3  4  5  6  7  8
LOCAL DET.....  0  0  0  0  0  0  0  0
ONE/TWO DET.....  1  1  1  1  1  1  1  1
VEH LENGTH.....  0  0  0  0  0  0  0  0
TRAP LENGTH.....  0  0  0  0  0  0  0  0
ENABLE LOG.....  .  .  .  .  .  .  .  .
  SPEED DET  9 10 11 12 13 14 15 16
LOCAL DET.....  0  0  0  0  0  0  0  0
ONE/TWO DET.....  1  1  1  1  1  1  1  1
VEH LENGTH.....  0  0  0  0  0  0  0  0
TRAP LENGTH.....  0  0  0  0  0  0  0  0
ENABLE LOG.....  .  .  .  .  .  .  .  .
    
```

**MM-6-5**

```

VEH DET DIAG
VEH DIAG PLAN NUMBER [ 1 ] | FAILED |
DET  COUNT|ACT|PRES| X'S|TIME|CL DELAY|
  1    255 255  255  60  255  0
  2     0  0  0  1  255  0
  3     0  0  0  1  255  0
  4     0  0  0  1  255  0
  5     0  0  0  1  255  0
  6     0  0  0  1  255  0
  7     0  0  0  1  255  0
  8     0  0  0  1  255  0
  9     0  0  0  1  255  0
 10     0  0  0  1  255  0
 11     0  0  0  1  255  0
 12     0  0  0  1  255  0
 13     0  0  0  1  255  0
    
```

```

VEH DET DIAG
VEH DIAG PLAN NUMBER [ 1 ] | FAILED |
DET  COUNT|ACT|PRES| X'S|TIME|CL DELAY|
 14     0  0  0  1  255  0
 15     0  0  0  1  255  0
 16     0  0  0  1  255  0
 17     0  0  0  1  255  0
 18     0  0  0  1  255  0
 19     0  0  0  1  255  0
 20     0  0  0  1  255  0
 21     0  0  0  1  255  0
 22     0  0  0  1  255  0
 23     0  0  0  1  255  0
 24     0  0  0  1  255  0
 25     0  0  0  1  255  0
 26     0  0  0  1  255  0
  //
 64     0  0  0  1  255  0
    
```

**MM-6-6**

PED DETECTOR DIAG PLAN[1] v				
DET	COUNTS	ACT	PRES	MULTIPLIER
1	0	0	0	1
2	0	0	0	1
3	0	0	0	1
4	0	0	0	1
5	0	0	0	1
6	0	0	0	1
7	0	0	0	1
8	0	0	0	1
9	0	0	0	1
10	0	0	0	1
11	0	0	0	1
12	0	0	0	1
13	0	0	0	1
14	0	0	0	1
15	0	0	0	1
16	0	0	0	1

**Main Status Display**

```

STATUS [CORD SYS P120] MM/DD/YY|HH:MM:SS
  PHASE 1 2 3 4 5 6 7 8 9 0 1 2 3 4 5 6
PH STAT . G R R G R R R - - - - -
VEH CALL . I I . . . . .
PED CALL . . . . .
R1/PH 04|R2/PH 08|R3/PH ..|R4/PH ..
MGR1 0.0|YEL 0.0|INACTIVE |INACTIVE
PDCL 12.0|FORCE OFF| |
PLAN SPLT:.12|TP:.4|SEQ:.1|ACT:100|DP:4
LC:115s/120|SYS CYC:110s|COS 111| COORD
FUNCTION 1 2 3 4 5 6 7 8 9 0 1 2 3 4 5 6
PMT|TSP - - - - - - - - -|X X X X X X
LP FLAG . A . . . A . . . . .
COMMUNICATIONS PORT STATUS|TLM ADD: 0
ETH RX TX|P2 RX TX|P3A RX TX|P3B RX TX
2 .- .-|1 OK OK|3 ID |3 . . .
    
```

**MM-7**

- STATUS DISPLAY SUBMENU
- 1. CONTROLLER
  - 2. COORDINATOR
  - 3. PREEMPTOR/TSP
  - 4. TBC/ACTION PLAN
  - 5. COMMUNICATIONS
  - 6. DETECTORS
  - 7. FLASH/SDLC/MMU
  - 8. INPUTS / OUTPUTS

**MM-7-1**

```

CONTROL [CORD SYS P120] MM/DD/YY|HH:MM:SS
  PHASE 1 2 3 4 5 6 7 8 9 0 1 2 3 4 5 6
  PH STAT . G R R G R R R - - - - -
VEH OVL R G R - - - - -
PED OVL - D - C - D - D - - - - -
VEH CALL . I I . . . . .
PED CALL . . . . .
PLAN SPLT:.12|TP:.4|SEQ:.1|ACT:100|DP:4
R1/PH 04|R2/PH 08|R3/PH ..|R4/PH ..
MGR1 0.0|YEL 0.0|INACTIVE |INACTIVE
PDCL 12.0|FORCE OFF| |
DEN00/000|DEN00/000|DEN00/000|DEN00/000
MAX 00.0|MAX 00.0|MAX 00.0|MAX 00.0
OLA G . |OLB Y 2.9|OLC R . |OLD R .
FUNCTION 1 2 3 4 5 6 7 8 9 0 1 2 3 4 5 6
LP FLAG . A . . . A . . . . .
    
```

**MM-7-2**

```

COORD [CORD SYS P120] MM/DD/YY|HH:MM:SS
  PHASE 1 2 3 4 5 6 7 8 9 0 1 2 3 4 5 6
  PH STAT R G R R G R R R - - - - -
VEH CALL . I I . . . . .
PED CALL . . . . .
PERMISVE . P . . V P . . . . .
PLAN SPLT:.12|TP:.4|SEQ:.1|ACT:100|DP:4
LC:115s/120|SYS CYL:110s|COS 111| COORD
LOCAL OFFSET... 0s ACTUAL OFFSET.. 0s
NEXT PLAN....XXXX NEXT TIME...xx:xx:xx
SPLIT DEMAND..XXX/00 RING 1 2 3 4
HOLD APPLIED TO PHASE 2 6 . .
FORCE OFF RING . . . .
SPLIT TIMING 0s 0s 0s 0s
SPLIT EXTENSION TIME 0s 0s 0s 0s
RING OFFSETS 0s 0s 0s 0s
    
```

**MM-7-3**

- PREEMPTION/TSP SUBMENU
- 1. PREEMPTOR
  - 2. TSP/SCP

▪ Appendix B

**MM-7-3-1**

```

PREEMPT [CORD SYS P120] MM/DD/YY|HH:MM:SS
  PHASE 1 2 3 4 5 6 7 8 9 0 1 2 3 4 5 6
  PH STAT R G R R G R R R - - - - -
  VEH OVL R O R G - - - - -
  PED OVL - D - D - D - D - - - - -
  VEH CALL . I I . . . . .
  PED CALL . . . . .
LC: 6s/ 0|SYS CYC: 0s|COS 111| COORD
R1/PH 4|R2/PH 8|R3/PH .|R4/PH .
  NOT PMT | CLR TRK | CYCLING | DWELL
MGR1 0.0|YEL 0.0|RED REST |RED REST
PDCL 12.0|FORCE OFF|
FUNCTION 1 2 3 4 5 6 7 8 9 0 1 2 3 4 5 6
PMT/TSP . . . . .|. . . . .
LP FLAG . A . . . A . . . . .
    
```

**MM-7-3-2**

```

TSP/SCP [FREE-TBC ] MM/DD/YY|HH:MM:SS
  PHASE 1 2 3 4 5 6 7 8 9 0 1 2 3 4 5 6
  PH STAT R G R R G R R R - - - - -
  VEH OVL - - - - -
  PED OVL W W W W W W W W W W W W W W
  VEH CALL . I I . . . . .
  PED CALL . . . . .
ACT TSP/SCP[0] | STATUS 1H 2H 3H 4H 5H 6H
PLAN SPLT:.12|TP:.4|SEQ:.1|ACT:100|DP:4
LC: 6s/ 0|SC: 0s[ FREE]TLM ADD: 0
R1/PH 4|R2/PH 8|R3/PH .|R4/PH .
MGR1 0.0|YEL 0.0|RED REST |RED REST
PDCL 12.0|FORCE OFF|
FUNCTION 1 2 3 4 5 6 7 8 9 0 1 2 3 4 5 6
PMT/TSP . . . . .|. . . . .
LP FLAG . A . . . A . . . . .
    
```

**MM-7-4**

TIME BASE STATUS DAY MM/DD/YY HH:MM:SS								
SOURCE...			TIME BASE	NEXT DAY PLAN:FRI				
#	SCHDL	DAY	PLN	DP	EVENT	ACT	PLN	START
1	1	WED	1		5		4	09:10
2	1	WED	1		6		5	11:45
3	1	WED	1		7		10	14:20
4	1	WED	1		12		2	15:45
5	1	WED	1		2		4	19:15
6	1	WED	1		1		1	21:00
7	1	THU	1		5		4	09:00
8	1	THU	1		6		5	11:45
9	1	WED	1		1		1	21:00
10	1	WED	1		1		1	21:00
11	0	---	0		0		0	00:00
12	0	---	0		0		0	00:00
13	0	---	0		0		0	00:00

#	SCHDL	DAY	PLN	DP	EVENT	ACT	PLN	START
//								
30	0	---	0		0		0	00:00

**MM-7-5**

```

COMMUNICATIONS SUBMENU

1. ETHERNET

2. PORT 2/C50S

3. PORT 3A/C21S

4. PORT 3B/C22S

5. NTCIP

6. ECPIP
    
```

**MM-7-5-1**

```

ETHERNET          DAY MM/DD/YY|HH:MM:SS
MAC ADDRESS..... FF:FF:FF:FF:FF:FF
LINK SPEED/DUPLEX..... 1000/FULL
RX PACKET COUNT..... 65535
TX PACKET COUNT..... 65535
RX PACKET ERROR COUNT..... 65535
TX PACKET ERROR COUNT..... 65535
DEFAULT GATEWAY REACHABLE..... YES

SERVER REACHABLE..... YES
    
```



**MM-7-5-2, Port 2 on ASC/3  
(AB3418)**

```

COMM PORT 2      DAY DD/MM/YY HH:MM:SS
RECEIVE..... X PROTOCOL..... AB3418
TRANSMIT..... X RX BYTE COUNT. 65535
READY TO SEND... X TX BYTE COUNT. 65535
CLEAR TO SEND... X DROP-OUT TIMER 65535
DATA TERM READY.. X
DATA SET READY... X
CARRIER DETECT... X
    
```

**MM-7-5-2, Port C50S on 2070 (AB3418)**

```

COMM PORT C50S  DAY MM/DD/YY|HH:MM:SS
RECEIVE..... X PROTOCOL..... AB3418
TRANSMIT..... X RX BYTE COUNT. 65535
                                     TX BYTE COUNT. 65535
    
```

**MM-7-5-2, Port 2 on ASC/3  
(NTCIP with ASC/3-IM)**

```

COMM PORT 2      DAY DD/MM/YY HH:MM:SS
RECEIVE..... X PROTOCOL..... NTCIP
TRANSMIT..... X RX BYTE COUNT. 65535
READY TO SEND... X TX BYTE COUNT. 65535
CLEAR TO SEND... X DROP-OUT TIMER 65535
DATA TERM READY.. X
DATA SET READY... X
CARRIER DETECT... X

INTERSECTION MONITOR:
COMMAND MODEM ANSWER..... X
    
```

**MM-7-5-2, Port C50S on 2070  
(NTCIP)**

```

COMM PORT C50S  DAY MM/DD/YY|HH:MM:SS
RECEIVE..... X PROTOCOL..... NTCIP
TRANSMIT..... X RX BYTE COUNT. 65535
                                     TX BYTE COUNT. 65535
    
```

**MM-7-5-2, Port 2 on ASC/3  
(ECPIP)**

```

COMM PORT 2      DAY DD/MM/YY HH:MM:SS
RECEIVE..... X PROTOCOL..... ECPIP
TRANSMIT..... X RX BYTE COUNT. 65535
READY TO SEND... X TX BYTE COUNT. 65535
CLEAR TO SEND... X DROP-OUT TIMER 65535
DATA TERM READY.. X
DATA SET READY... X
CARRIER DETECT... X
    
```

**MM-7-5-2, Port C50S on 2070 (ECPIP)**

(not supported)

**MM-7-5-2, Port 2 on ASC/3  
(TERM)**

```

COMM PORT 2      DAY DD/MM/YY HH:MM:SS
RECEIVE..... X PROTOCOL..... TERM
TRANSMIT..... X RX BYTE COUNT. 65535
READY TO SEND... X TX BYTE COUNT. 65535
CLEAR TO SEND... X
DATA TERM READY.. X
DATA SET READY... X
CARRIER DETECT... X
    
```

**MM-7-5-2, Port C50S on 2070 (TERM)**

```

COMM PORT C50S  DAY MM/DD/YY|HH:MM:SS
RECEIVE..... X PROTOCOL..... TERM
TRANSMIT..... X
    
```

▪ Appendix B

**MM-7-5-3, Port 3A on ASC/3  
(AB3418)**

```
COMM PORT 3A      DAY DD/MM/YY HH:MM:SS
RECEIVE..... X PROTOCOL..... AB3418
TRANSMIT..... X RX BYTE COUNT. 65535
READY TO SEND... X TX BYTE COUNT. 65535
CARRIER DETECT... X DROP-OUT TIMER 65535
```

**MM-7-5-3, Port C21S on 2070 (AB3418)**

```
COMM PORT C21S   DAY DD/MM/YY HH:MM:SS
RECEIVE..... X PROTOCOL..... AB3418
TRANSMIT..... X RX BYTE COUNT. 65535
READY TO SEND... X TX BYTE COUNT. 65535
CLEAR TO SEND... X DROP-OUT TIMER 65535
DATA TERM READY.. X
DATA SET READY... X
CARRIER DETECT... X
```

**MM-7-5-3, Port 3A on ASC/3  
(NTCIP)**

```
COMM PORT 3A      DAY DD/MM/YY HH:MM:SS
RECEIVE..... X PROTOCOL..... NTCIP
TRANSMIT..... X RX BYTE COUNT. 65535
READY TO SEND... X TX BYTE COUNT. 65535
CARRIER DETECT... X DROP-OUT TIMER 65535
```

**MM-7-5-3, Port C21S on 2070  
(NTCIP)**

```
COMM PORT C21S   DAY DD/MM/YY HH:MM:SS
RECEIVE..... X PROTOCOL..... NTCIP
TRANSMIT..... X RX BYTE COUNT. 65535
READY TO SEND... X TX BYTE COUNT. 65535
CLEAR TO SEND... X DROP-OUT TIMER 65535
DATA TERM READY.. X
DATA SET READY... X
CARRIER DETECT... X
```

**MM-7-5-3, Port 3A on ASC/3  
(ECPIP)**

```
COMM PORT 3A      DAY DD/MM/YY HH:MM:SS
RECEIVE..... X PROTOCOL..... ECPIP
TRANSMIT..... X RX BYTE COUNT. 65535
READY TO SEND... X TX BYTE COUNT. 65536
CARRIER DETECT... X DROP-OUT TIMER 65535
```

**MM-7-5-3, Port C21S on 2070 (ECPIP)**

(not supported)

**MM-7-5-3, Port 3A on ASC/3  
(TERM)**

```
COMM PORT 3A      DAY DD/MM/YY HH:MM:SS
RECEIVE..... X PROTOCOL..... TERM
TRANSMIT..... X RX BYTE COUNT. 65535
READY TO SEND... X TX BYTE COUNT. 65535
CARRIER DETECT... X
```

**MM-7-5-3, Port C21S on 2070 (TERM)**

```
COMM PORT C21S   DAY DD/MM/YY HH:MM:SS
RECEIVE..... X PROTOCOL..... TERM
TRANSMIT..... X RX BYTE COUNT. 65535
READY TO SEND... X TX BYTE COUNT. 65535
CLEAR TO SEND... X
DATA TERM READY.. X
DATA SET READY... X
CARRIER DETECT... X
```

**MM-7-5-4, Port 3B on ASC/3  
(AB3418)**

```
COMM PORT 3B      DAY DD/MM/YY HH:MM:SS
ENABLE..... RS232 PROTOCOL..... AB3418
BIT RATE.... 115200 ADDRESS..... 65535
D/P/S..... 8/N/1 GROUP ADDRESS. 65535
DUPLEX..... HALF SINGLE FLAGGED.. YES
FLOW CONTROL... YES DROP-OUT TIME. 65535
RTS-CTS DELAY. 6810
RTS TURN OFF.. 6810
EARLY RTS..... YES
```

**MM-7-5-4, Port C22S on 2070 (AB3418)**

```
COMM PORT C22S   DAY DD/MM/YY HH:MM:SS
RECEIVE..... X PROTOCOL..... AB3418
TRANSMIT..... X RX BYTE COUNT. 65535
READY TO SEND... X TX BYTE COUNT. 65535
CLEAR TO SEND... X DROP-OUT TIMER 65535
DATA TERM READY.. X
DATA SET READY... X
CARRIER DETECT... X
```

**MM-7-5-4, Port 3B on ASC/3  
(NTCIP)**

```
COMM PORT 3B      DAY DD/MM/YY HH:MM:SS
ENABLE..... YES PROTOCOL..... NTCIP
BIT RATE.... 115200 ADDRESS..... 65535
D/P/S..... 8/N/1 GROUP ADDRESS. 65535
DUPLEX..... HALF SINGLE FLAGGED.. YES
FLOW CONTROL... YES DROP-OUT TIME. 65535
RTS-CTS DELAY. 6810
RTS TURN OFF.. 6810
EARLY RTS..... YES
```

**MM-7-5-4, Port C22S on 2070  
(NTCIP)**

```
COMM PORT C22S   DAY DD/MM/YY HH:MM:SS
RECEIVE..... X PROTOCOL..... NTCIP
TRANSMIT..... X RX BYTE COUNT. 65535
READY TO SEND... X TX BYTE COUNT. 65535
CLEAR TO SEND... X DROP-OUT TIMER 65535
DATA TERM READY.. X
DATA SET READY... X
CARRIER DETECT... X
```

**MM-7-5-4, Port 3B on ASC/3  
(ECP/IP)**

```
COMM PORT 3B      DAY DD/MM/YY HH:MM:SS
ENABLE..... YES PROTOCOL..... ECP/IP
BIT RATE.... 115200 ADDRESS..... 65535
D/P/S..... 8/N/1 TRD (ms)..... 255
DUPLEX..... HALF DROP-OUT TIME. 65535
FLOW CONTROL... YES
RTS-CTS DELAY. 6810
RTS TURN OFF.. 6810
EARLY RTS..... YES
```

**MM-7-5-4, Port C22S on 2070 (ECP/IP)**

(not supported)

**MM-7-5-4, Port 3B on ASC/3  
(TERM)**

```
COMM PORT 3B      DAY DD/MM/YY HH:MM:SS
RECEIVE..... X PROTOCOL..... TERM
TRANSMIT..... X RX BYTE COUNT. 65535
READY TO SEND... X TX BYTE COUNT. 65535
CLEAR TO SEND... X
DATA TERM READY.. X
DATA SET READY... X
CARRIER DETECT... X
```

**MM-7-5-4, Port C22S on 2070 (TERM)**

```
COMM PORT C22S   DAY DD/MM/YY HH:MM:SS
RECEIVE..... X PROTOCOL..... TERM
TRANSMIT..... X RX BYTE COUNT. 65535
READY TO SEND... X TX BYTE COUNT. 65535
CLEAR TO SEND... X
DATA TERM READY.. X
DATA SET READY... X
CARRIER DETECT... X
```

▪ Appendix B

**MM-7-5-5**

```

NTCIP          DAY MM/DD/YY|HH:MM:SS
      1 2 3 4 5 6 7 8 9 0 1 2 3
DYNAMIC OBJ   X X X X X X X X X X X X
SPECIAL FUNC  X X X X X X X X
RX SNMP MESSAGE COUNT..... 65535
TX SNMP MESSAGE COUNT..... 65535
RX STMP MESSAGE COUNT..... 65535
TX STMP MESSAGE COUNT..... 65535
ACTIVE CONTORL PORT..... C50S
LAST TIME SYNC..... 65535
TRANSACTION MODE..... YES
CONFIGURATION TRANSFER IN PROGRESS. NO
    
```

**MM-7-5-6 (ASC/3 only)**

```

ECPIP          DAY DD/MM/YY|HH:MM:SS
      1 2 3 4 5 6 7
TELEMETRY MODE X X X X X X X
SPECIAL FUNCTION X X X X
RX MESSAGE COUNT..... 65535
TX MESSAGE COUNT..... 65535
RX MESSAGE ERROR COUNT..... 65535
TX MESSAGE ERROR COUNT..... 65535
LAST VALID COMMAND..... 65535

LAST TIME SYNC..... 65535
CONFIGURATION TRANSFER IN PROGRESS. NO
    
```

**MM-7-6**

```

DETECTOR STATUS MM/DD/YY|HH:MM:SS
DET [ 5]TIME 0.0 DELAY 0.0 EXTEND 0.0
DET DIAG|CTR:MAX PRES |TS2:Excess Change
DET PH  1 2 3 4 5 6 7 8 9 0 1 2 3 4 5 6
1  1  . . . . .
01-08 . . . . C . . C 01-08
09-16 . . . . . 09-16
17-24 . . . . . 17-24
25-32 . . . . . - 25-32
33-40 - - - - - 33-40
41-48 - - - - - 41-48
49-56 - - - - - 49-56
57-64 - - - - - 57-64
    
```

**MM-7-7**

```

FLASH/SDLC/MMU STATUS
1. FLASH STATUS
2. SDLC STATUS
3. MMU STATUS
4. MMU EXTENDED STATUS
5. MMU AC STATUS
6. MMU COMPATIBILITY STATUS
    
```

**MM-7-7-1**

```

FLASH STATUS:
AUTOMATIC FLASH

AUTO FLASH REMOTE INPUT

RING 1
RING 2
    
```

**MM-7-7-2**

```

SDLC STATUS

MMU 128  DISABLED  TF  138  DISABLED
      129  DISABLED  139  DISABLED
      131  DISABLED  140  DISABLED
                                141  DISABLED
MMU STATUS:MMU DISABLED

DET 148  DISABLED  DET 152  DISABLED
      149  DISABLED  153  DISABLED
      150  DISABLED  154  DISABLED
      151  DISABLED  155  DISABLED

TEST 158  DISABLED
    
```

**MM-7-7-3**

```

MMU STATUS                      MFG: .....
CHANNEL  1 2 3 4 5 6 7 8 9 0 1 2 3 4 5 6
RED.....
YELLOW..
GREEN...
FAULT...
ENA-Y-CK X . X . X . X . . X . X . X . X
FAIL STATS . RLY TRANFR . CONFLICT...
SPARE 1... . SPARE 2... . SPARE 3....
SPARE 4... . SPARE 5... . SPARE 6....
PORT 1 FL. . RED FAIL.. . MIN CL FAIL .
CVM..... . MMU DIAG.. . STRUP FL CL .
24V MON 1. . 24V MON 2. . 24V MON INH .
MMU RESET. . RED ENABLE . LOCAL AU/FL .
FL TIME. 5s 24V LATCH. X CVM LATCH.. X
    
```

**MM-7-7-4**

```

MMU EXT STATUS                  MFG: EDI
CHANNEL  1 2 3 4 5 6 7 8 9 0 1 2 3 4 5 6
FC/RED..
FC/YEL..
FC/GREEN .
RP/RED..
RP/YEL..
RP/GREEN .
RY GON..
FAULT...
LAST FAULT REPORT: 00:00:00 00/00/00
NO FAULT
    
```

**MM-7-7-5**

```

MMU AC STATUS                   MFG: ...
NO FAULT
AC LINE: 0 VRMS AT N/A HZ,TEMP: -40 F
RED ENABLE: 0 VRMS
CHANNEL: 01 02 03 04 05 06 07 08
  RED: 0 0 0 0 0 0 0 0
  YEL: 0 0 0 0 0 0 0 0
  GRN: 0 0 0 0 0 0 0 0
CHANNEL: 09 10 11 12 13 14 15 16
  RED: 0 0 0 0 0 0 0 0
  YEL: 0 0 0 0 0 0 0 0
  GRN: 0 0 0 0 0 0 0 0

LAST FAULT REPORT: 00/00/00 00:00:00
    
```

**MM-7-7-6**

```

MMU COMPATIBILITY STATUS MFG:
CH|6 5 4|3 2 1|0 9 8|7 6 5|4 3 2
1 . . . . . X . . . . . X X . . .
2 . . . . . X . X . C X X . .
3 . . . . . X . . . X X . . .
4 . . . M X . X . X X . . .
5 . . . . . . . X . . . .
6 . . . . . X . X . . . .
7 . . . . . . . X . . . .
8 . . . . . X . X . . . .
9 . . . . . X . . . . . .
10 . . . . . X . . . . . .
11 . . . . . . . . . . . .
12 . . . . . . . . . . . .
13 . . . . . . . . . . . .
14 . . . . . . . . . . . .
15 . . . . . . . . . . . .
    
```

**MM-7-8**

```

INPUT / OUTPUT SUBMENU

1.CONTROLLER INPUTS 6.T&f BIU I/O
2.CONTROLLER OUTPUTS 7.D/R BIU I/O
3.HARDWARE INPUTS 8.LOGIC PROCESSOR
4.HARDWARE OUTPUTS 9.I/O DIFFERENCES
5.AUX HARDWARE I/O
    
```

▪ Appendix B

**MM-7-8-1 (NEMA Functional Inputs)**

INPUTS FUNCTIONS								v
PHASE	1	2	3	4	5	6	7	8
VEH DET..	.	.	.	.	.	.	.	.
PED DET..	.	.	.	.	.	.	.	.
VEH OMIT.	.	.	.	.	.	.	.	.
PED OMIT.	.	.	.	.	.	.	.	.
HOLD.....	.	.	.	.	.	.	.	.
INPUTS- RG 1 RG 2								
FORCE OFF...	.	.	.	.	.	.	.	.
INHIBIT MAX.	.	.	.	.	.	.	.	.
MAX II.....	.	.	.	.	.	.	.	.
OMIT RED CL.	.	.	.	.	.	.	.	.
PED RECYCLE.	.	.	.	.	.	.	.	.
RED REST.....	.	.	.	.	.	.	.	.
STOP TIME...	.	.	.	.	.	.	.	.
INPUTS--								
PREEMPT.....	2--	4--	5--	6--	.	.	.	.
IO MODE SELECT.	A--	B--	C--	.	.	.	.	.
TEST INPUT.....	A--	B--	C--	.	.	.	.	.
CALL NON ACT...	1--	2--	.	.	.	.	.	.
COORD/FREE. .	EXT START.		MINRECALL.	.	.	.	.	.
LAMP OFF... .	INTER ADV.		MCE.....	.	.	.	.	.
WLK RST MOD .		.	.	.	.	.	.	.

**MM-7-8-1 (332 Layout Inputs)**

C1/C11 INPUT FUNCTIONS														v
I INPUT FILE														
S#01	02	03	04	05	06	07	08	09	11	12	13	14		
P#56	39	63	47	58	41	65	49	60	80	67	68	81		
F:	.	.	.	.	.	.	.	.	.	.	.	.	.	.
P#..	43	76	..	..	45	78	..	62	53	69	70	82		
W:	.	.	.	.	.	.	.	.	.	.	.	.	.	.
J INPUT FILE														
S#01	02	03	04	05	06	07	08	09	11	12	13	14		
P#55	40	64	48	57	42	66	50	59	54	71	72	51		
F:	.	.	.	.	.	.	.	.	.	.	.	.	.	.
P#..	44	77	..	..	46	79	..	61	75	73	74	52		
W:	.	.	.	.	.	.	.	.	.	.	.	.	.	.
2A MODULE C11S INPUTS														
PIN#	10	11	12	13	15	16	17	18	19					
FUNC:	.	.	.	.	.	.	.	.	.	.	.	.	.	.
PIN#	20	21	22	23	24	25	26	27	28	29	30			
FUNC:	.	.	.	.	.	.	.	.	.	.	.	.	.	.

**MM-7-8-2 (NEMA Functional Outputs)**

OUTPUT FUNCTIONS								
PHASE	1	2	3	4	5	6	7	8
RED.....	.	.	.	.	.	.	.	.
YELLOW...	.	.	.	.	.	.	.	.
GREEN....	.	.	.	.	.	.	.	.
DONT WALK .	.	.	.	.	.	.	.	.
PED CLEAR .	.	.	.	.	.	.	.	.
WALK.....	.	.	.	.	.	.	.	.
PH CHECK. .	.	.	.	.	.	.	.	.
PH NEXT.. .	.	.	.	.	.	.	.	.
PHASE ON. .	.	.	.	.	.	.	.	.
OVLP A	B	C	D	RING	1	2	SPEC	
RED .	.	.	.	STAT A	.	.	CVM .	
YEL .	.	.	.	STAT B	.	.	FM .	
GRN .	.	.	.	STAT C	.	.	FL .	

**MM-7-8-2 (332 Layout Outputs)**

C1/C11 OUTPUT FUNCTIONS														
PH:	V1	V2	P2	V3	V4	P4	V5	V6	P6	V7	V8	P8		
PIN#	16	12	10	07	04	02	32	29	27	24	21	19		
RED:	.	.	.	.	.	.	.	.	.	.	.	.	.	.
PIN#	17	13	35	08	05	37	33	30	36	25	22	38		
YEL:	.	.	.	.	.	.	.	.	.	.	.	.	.	.
PIN#	18	15	11	09	06	03	34	31	28	26	23	20		
GRN:	.	.	.	.	.	.	.	.	.	.	.	.	.	.
2A MODULE C1 OUTPUTS														
OL:	A	B	C	D	TBC	FUNCTION	SPARE							
PIN#	97	94	88	85	83		101	91						
RED:	.	.	.	.	SF1	.	CABFLASH	.	SP	-				
PIN#	98	95	89	86	100		102	93						
YEL:	.	.	.	.	SF2	.	DETRESET	.	SP	.				
PIN#	99	96	90	87	84		103							
GRN:	.	.	.	.	SF3	.	WATCHDOG	.						
2A MODULE C11S OUTPUTS														
PIN#	01	02	03	04	05	06	07	08						
.	.	.	.	.	.	.	.	.	.	.	.	.	.	.

**MM-7-8-3 (NEMA A, B, C Inputs)**

ABC INPUTS	
CONNECTOR MS-A	K L M N P R S T f g h
INPUTS	. . . . .
CONNECTOR MS-A	i j k m n q v w x y z
INPUTS	. . . . .
CONNECTOR MS-A	AA BB EE FF GG HH
INPUTS	. . . . .
CONNECTOR MS-B	B L M N P R S T U V W X
INPUTS	. . . . .
CONNECTOR MS-B	g h i j k m n v x y z
INPUTS	. . . . .
CONNECTOR MS-C	P R S T U V W X Y Z a b
INPUTS	. . . . .
CONNECTOR MS-C	m n p q r s t u v EE
INPUTS	. . . . .

**MM-7-8-3 (332 C1 & C11 Inputs)**

C1/C11 INPUTS	
CONNECTOR	PIN
C1-Input	39 40 41 42 43 44 45 46 47 48
INPUTS	. . . . .
C1-Input	49 50 51 52 53 54 55 56 57 58
INPUTS	. . . . .
C1-Input	59 60 61 62 63 64 65 66 67 68
INPUTS	. . . . .
C1-Input	69 70 71 72 73 74 75 76 77 78
INPUTS	. . . . .
C1-Input	79 80 81 82
INPUTS	. . . . .
C11-Input	10 11 12 13 15 16 17 18 19 20
INPUTS	. . . . .
C11-Input	21 22 23 24 25 26 27 28 29 30
INPUTS	. . . . .
INPUTS	
ASC3 1000/2070 2N MODULE	
There are no HARDWARE inputs for this Controller. To view I/O on this Controller, check T&F or D/R I/O.	

**MM-7-8-4 (NEMA A, B, C Outputs)**

ABC OUTPUTS		v
CONNECTOR	PINS	
MS-A	A C D E F G H J X Y Z	
INPUTS	. . . . .	
MS A	a b c d e r s t u CC DD	
INPUTS	. . . . .	
MS-B	A C D E F G H J K Y Z a	
INPUTS	. . . . .	
MS B	b c d e f p q r s t u w	
INPUTS	. . . . .	
MS B	AA BB CC DD EE FF GG HH	
INPUTS	. . . . .	
MS-C	A B C D E F G H J K L M N	
INPUTS	. . . . .	
MS C	c d e f g h i j k w x y z	
INPUTS	. . . . .	
MS C	AA BB CC DD FF GG HH	
INPUTS	. . . . .	
MS C	JJ KK LL MM NN PP	
INPUTS	. . . . .	

**MM-7-8-4 (332 C1 & C11 Outputs)**

C1/C11 OUTPUTS	
CONNECTOR	
C1-02	03 04 05 06 07 08 09 10 11 12 13
INPUTS	. . . . .
C1-15	16 17 18 19 20 21 22 23 24 25 26
INPUTS	. . . . .
C1-27	28 29 30 31 32 33 34 35 36 37 38
INPUTS	. . . . .
C1-83	84 85 86 87 88 89 90 91 90 91
INPUTS	. . . . .
C1-93	94 95 96 97 98 99 100 101 102 103
INPUTS	. . . . .
C11-01	02 03 04 05 06 07 08
INPUTS	. . . . .
OUTPUTS	
ASC3 1000/2070 2N MODULE	
There are no HARDWARE outputs for this Controller. To view I/O on this Controller, check T&F or D/R I/O.	

▪ Appendix B

**MM-7-8-5 (NEMA Auxiliary Hardware I/O)**

D I/O												
01	02	03	04	05	06	07	08	09	10	11	12	13
O	O	I	I	O	I	*	0	I	I	O	I	I
14	15	16	17	18	19	20	21	22	23	24	25	26
I	O	I	I	I	I	I	O	O	O	O	I	I
27	28	29	30	31	32	33	34	35	36	37	38	39
O	O	O	I	I	O	O	O	I	I	I	I	I
40	41	42	43	44	45	46	47	48	49	50	51	52
I	O	O	O	O	O	O	I	O	I	I	O	O
53	54	55	56	57	58	59	60	61				
O	O	I	I	I	I	O	I	I				
ASC3 TLM I/O												
TELEMETRY												
01	02	03	04	05	06	07	08	09	10	11	12	13
I	I	I	I	I	I	I	I	O	O	*	*	*
14	15	16	17	18	19	20	21	22	23	24	25	
I	I	I	I	I	I	I	I	O	O	*	*	

**MM-7-8-5 (332 Auxiliary Hardware I/O)**

D I/O												
A	B	C	D	E	F	G	H	J	K	L	M	N
I	I	I	I	I	I	I	I	I	I	I	I	I
X	Y	Z	a	b	c	d	e	f	g	h	i	j
I	I	I	I	I	I	I	I	I	I	I	I	I
t	u	v	w	x	y	z	AA	BB	CC	DD	EE	FF
I	I	I	I	I	O	O	O	O	O	O	O	O
KK	LL	MM	NN	PP								
*	O	*	*	*								

**MM-7-8-6**

T&F BIU I/O													
BIU # 1	I/O Function												
TF- OUT	1	2	3	4	5	6	7	8					
	.	.	.	.	.	.	.	.					
OUT	9	10	11	12	13	14	15						
	.	.	.	.	.	.	.						
TF- I/O	01	02	03	04	05	06	07	08					
	IO	IO	IO	IO	IO	IO	IO	IO					
I/O	09	10	11	12	13	14	15	16					
	IO	IO	IO	IO	IO	IO	IO	IO					
I/O	17	18	19	20	21	22	23	24					
	IO	IO	IO	IO	IO	IO	IO	IO					
TF- IN	1	2	3	4	5	6	7	8					
	.	.	.	.	.	.	.	.					
TF- OPTO	1	2	3	4									
	.	.	.	.									

**MM-7-8-7**

D/R BIU I/O													
BIU # 1	I/O Function												
DR- DETECTOR	1	2	3	4	5	6	7	8					
	.	.	.	.	.	.	.	.					
DETECTOR	9	10	11	12	13	14	15	16					
	.	.	.	.	.	.	.	.					



**MM-7-8-8-1  
(Logic Processor Gate Status)**

```

LOGIC #98 ACTIVE: Y
RESULT: FALSE
IF GREEN ON PHASE      10 IS ON    F
AND VEHICLE DET #     1 IS ON    F
OR MINGRN TMR ON PHASE 10 < 15.7  F

THEN SET VEHICLE DET # 1 OFF
   SET GREEN OVERLAP   B OFF
   SET YELLOW OVERLAP  B ON

ELSE DELAY FOR         15.7 SECONDS
   SET VEHICLE DET #  1 ON
    
```

**MM-7-8-8-2 (Manual Logic  
Processor Statement Enable Plan Status)**

```

LOGIC PROCESSOR ENABLE PLAN
      1 2 3 4 5 6 7 8 9 0 1 2 3 4 5
LP  1-15 . . . . .
LP  16-30 . . . . .
LP  31-45 . . . . .
LP  46-60 . . . . .
LP  61-75 . . . . .
LP  76-90 . . . . .
LP  91-100 . . . . .
    
```

**MM-7-8-9**

```

M CNR/PIN  DEFAULT DB  ACTIVE DB
0 A/o-F    PHASE 02 RED  PHASE 04 RED
0 A/o-d    PHASE 02 CHK  PHASE 10 RED
0 A/i-h    PHASE 01 HOLD PHASE 10 HOLD
0 B/o-E    PHASE 03 YEL  PHASE 04 YEL
0 C/o-C    PHASE 08 DWK  PHASE 06 DWK
TF1/o-18B  DIMMING ENABLE TLM SPC FUNC 2
TF1/o-02B  LOADSW 09 YEL PHASE 01 GRN
TF1/x-21A  NOT ASSIGN  OVERLP I GRN
0 T/i-16   MAINTENANCE REQ PHASE 10 OMIT
- C01o103
- C11o07
    
```

**MM-8**

```

UTILITIES SUBMENU

1. COPY                5. SIGN ON
2. USB MANAGEMENT     6. LOG BUFFERS
3. PRINT               7. SOFTWARE MODULES
4. TRANSFER
    
```

**MM-8-1**

```

COPY / CLEAR UTILITY          v
FROM      >      TO
PHASE TIMING.... . > PHASE TIMING.... .
TIMING PLAN.... . > TIMING PLAN.... .
PH DET OPT PLAN. . > PH DET OPT PLAN. .
DETECTOR PLAN... . > DETECTOR PLAN... .
COORD PATTERN... . > COORD PATTERN... .
SPLIT PATTERN... . > SPLIT PATTERN... .
SEQUENCE..... . > SEQUENCE..... .
ACTION PLAN.... . > ACTION PLAN.... .
PREEMPT PLAN.... . > PREEMPT PLAN.... .
LP STATEMENT.... . > LP STATEMENT.... .
DATA KEY..... . > CONTROLLER DATA. .
CONTROLLER DATA. . > DATA KEY..... .

DEFAULT DATABASE . > CONTROLLER DATA. .
ECONOLITE DBASE. . > CONTROLLER DATA. .
CONTROLLER DATA. . > DEFAULT DATA.... .
MMU PROGRAM..... . > CONTROLLER..... .
SPECIAL FEATURES . > CONTROLLER..... .
  TOGGLE TO SELECT A "FROM" AND A "TO"
  THEN PRESS ENTER
    
```

▪ Appendix B

**MM-8-2**

```
USB OPTIONS

1 SOFTWARE UPDATE

2 CONFIGURATION UPDATE

3 SAVE FROM CONTROLLER
```

**MM-8-2-1**

```
USB COPY SUCCEEDED

*****
* PLEASE REMOVE ALL USB FLASH DRIVES. *
* TURN OFF FOR 3 SECONDS THEN TURN ON. *
*****
```

**MM-8-2-2**

```
SELECT FILE
/media/usb/
>.
DB_10.70.10.51_130127_083444.CFG
DB_10.70.10.51_130128_081531.CFG
DB_10.70.10.51_130225_174233.CFG
DB_10.70.10.51_130301_154416.CFG
PRESS 1 ON CFG OR DB TO BE UPDATED
```

**MM-8-2-3**

```
USB OPTIONS

1 SAVE CURRENT CONFIGURATION (CFG)
2 PRINT CONFIGURATION
3 PRINT LOGS
4 SAVE VIOT FILE
5 SAVE ALL
```

**MM-8-2-3-1**

```
SAVE CURRENT CONFIGURATION (CFG)

SUCCESSFUL COMPLETION
```

**MM-8-2-3-2**

```
PRINT CONFIGURATION

SUCCESSFUL COMPLETION
```

**MM-8-2-3-3**

```
PRINT LOGS

SUCCESSFUL COMPLETION
```

**MM-8-2-3-4**

```
SAVE VIOT FILE

SUCCESSFUL COMPLETION
```

**MM-8-2-3-5**

```
SAVE ALL

SUCCESSFUL COMPLETION
```

**MM-8-3**

```

PRINT

PRINT TO PORT... 2
                SELECT ALL..... .

CONFIGURATION... . TIME BASE..... .

CONTROLLER..... . DETECTOR..... .

COORDINATOR..... . LOGIC PROCESSOR. .

PREEMPTOR..... . TSP AND SCP..... .

TOGGLE TO SELECT AND THEN PRESS ENTER
TO BEGIN PRINTING
    
```

**MM-8-4**

```

TRANSFER UTILITY

PORT..... 2
DIRECTION.....TRANSMIT

DATABASE..... .

COMMAND MODEM ANSWER. .

TOGGLE TO SELECT THEN PRESS ENTER
TO TRANSFER
    
```

**MM-8-5**

```

*****
* ECONOLITE CONTROL PRODUCTS, INC. *
*                                     *
*           ASC/3-2100                *
*       Copyright (C) 2004-2013        *
*                                     *
*   Solutions that Move the World     *
*                                     *
* CITY.... 0 INTERSECTION.. 0 *
*                                     *
* SOFTWARE.....V2.55.00 *
*                                     *
*                                     *
*                                     *
* CONFIGURATION..... N3000 *
*****
    
```

**MM-8-6**

```

LOG BUFFERS SUBMENU

1. DISPLAY

2. PRINT

3. CLEAR
    
```

**MM-8-6-1**

```

DISPLAY SUBMENU

1. CONTROLLER EVENTS

2. DETECTOR EVENTS

3. DETECTOR ACTIVITY

4. MMU EVENTS
    
```

**MM-8-6-2**

```

PRINT LOG BUFFERS

PRINT TO PORT..... 2
NUMBER OF DAYS..... 10

CONTROLLER EVENTS..... .
DETECTOR EVENTS..... .
DETECTOR ACTIVITY..... .
MMU EVENTS..... .
SELECT ALL..... .

PRESS 0..9 OR TOGGLE TO SELECT
THEN ENTER TO PRINT
    
```

▪ Appendix B

**MM-8-6-3**

CLEAR SUBMENU

1. CONTROLLER EVENTS
2. DETECTOR EVENTS
3. DETECTOR ACTIVITY
4. MMU EVENTS
5. ALL LOGS

**MM-8-7**

SOFTWARE MODULES

NAME	PART NUMBER	VERSION
BOOT	N/A	N/A
APPLICATION	100-1082-242	V2.55.00
CONFIGURATION	100-1049-001	N3000, 2
HELP	100-1050-001	01.00.00
DEFINITIONS	100-1051-001	02.10.00
TEXT	100-1052-001	02.10.00
TELEMETRY	N/A	N/A

**MM-9**

DIAGNOSTICS SUBMENU

1. DIAGNOSTICS INFORMATION
2. WARNING CHECKS
3. ADVANCED DIAGNOSTICS

**MM-9-1**

DIAGNOSTICS INFORMATION

HARDWARE DIAGNOSTICS ARE PERFORMED WHILE THE CONTROLLER IS NOT OPERATIONAL.

REFER TO APPENDIX F IN THE PROGRAMMING MANUAL FOR INSTRUCTIONS ON LOADING THE DIAGNOSTIC FILE AND ITS OPERATION.

**MM-9-2**

WARNING CHECK SUBMENU

1. ENABLE WARNING CHECK CATEGORIES
2. COMPILE & VIEW ACTIVE WARNINGS
3. VIEW/EDIT DISABLED WARNINGS

**MM-9-2-1**

WARNING CHECK SELECTION - DISABLE ALL

WARNING CHECK	ENABLED
1. CONFIGURATION	NO
2. CONTROLLER	NO
3. COORDINATOR	NO
4. PREEMPTOR/TSP	NO
5. TIME BASE	NO
6. DETECTORS	NO
7. AT DATA ENTRY	NO

NOTE: Controller automatically performs Warning Check at power up only. User should run Warning Check with MM-9-2-2 after data entry changes. Individual Warnings can be disabled at MM-9-2-3

**MM-9-2-2 (example)**

```
ACTIVE DIAGNOSTIC WARNING CHECKS (WC)
1201 Inactive Exclusive Ped Phase
1202 In-use phase not in sequence
3101 Manual Pattern enabled
4104 Preempt MAX Presence time enabled
```

**MM-9-2-3 (example)**

```
WARNING CHECKS [1201]      COMMANDS      .
Inactive Exclusive Ped Phase
DISABLED WARNING CHECKS:
2101 2102 3101 3201 3202 3301 3302 3304
```

**Startup Warning Display**

```
STATUS [CORD SYS P120] MM/DD/YY|HH:MM:SS
  PHASE 1 2 3 4 5 6 7 8 9 0 1 2 3 4 5 6
PH STAT . G R R G R R R - - - - -
VEH CALL . I I . . . . .
*****
*   DATABASE IRREGULARITIES FOUND   *
*   GO TO MM-9-2-2 FOR DETAILS.     *
*                                     *
*   TO DISABLE A SPECIFIC WARNING,  *
*   GO TO MM-9-2-3.                 *
*****
PMT|TSP - - - - - - - -|X X X X X
LP FLAG . A . . . A . . . . .
COMMUNICATIONS PORT STATUS|TLM ADD:  0
ETH RX TX|P2  RX TX|P3A RX TX|P3B RX TX
2  .- .-|1  OK OK|3  ID  |3  . . .
```

---

**For your notes:**



---

# Reserved

(reserved for future use)

---

**For your notes:**



---

# Program Reference Card

## ASC/3 Program Reference Card

Intersection: \_\_\_\_\_

Controller Number: \_\_\_\_\_ Entered By: \_\_\_\_\_ Date: \_\_/\_\_/\_\_

Boot: \_\_\_\_\_ Main: \_\_\_\_\_ Help: \_\_\_\_\_ Database: \_\_\_\_\_

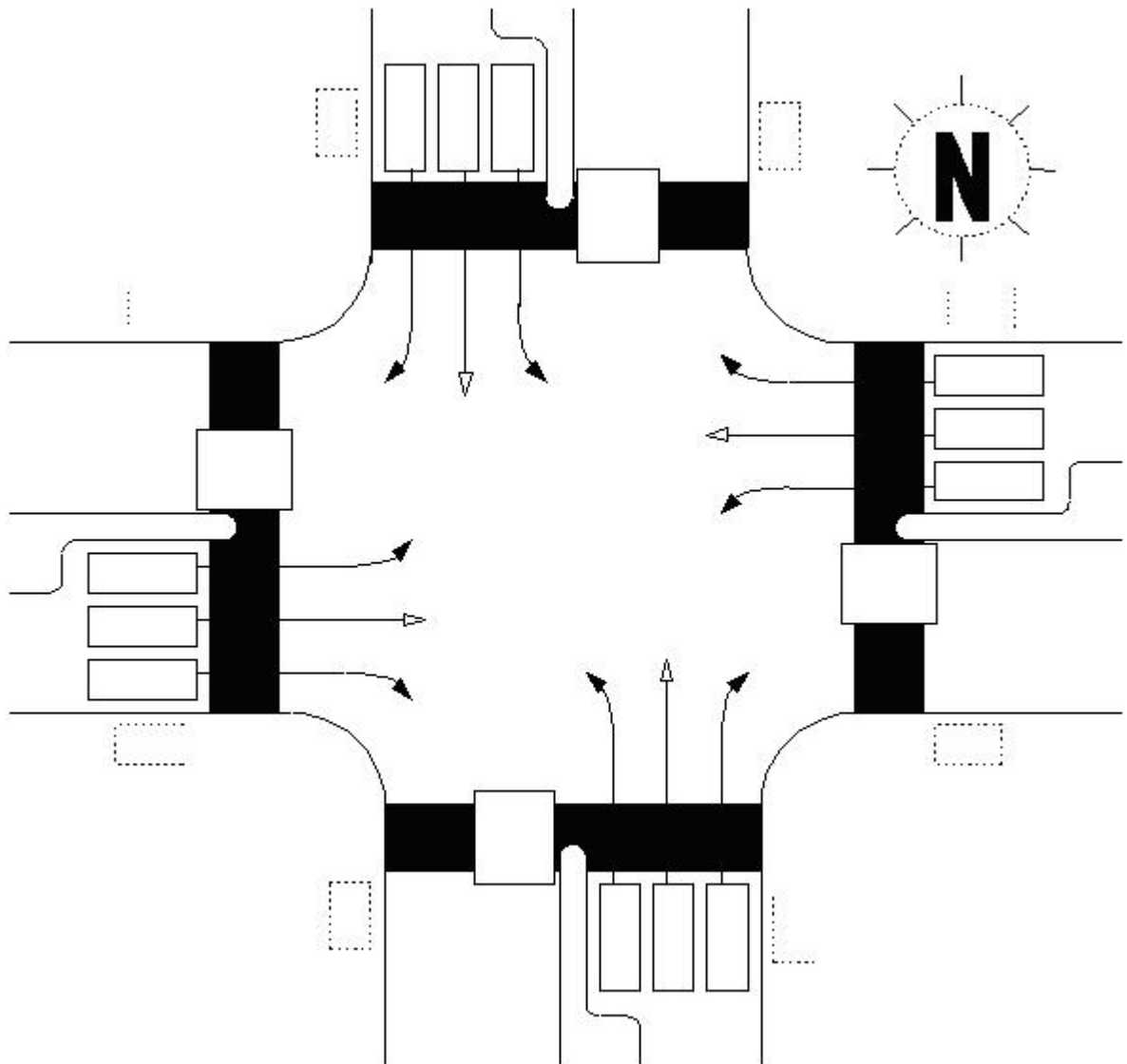

## Configuration Submenu

### MM-1-1-1 Phase Ring Assignment (PRI = Priority)

Sequence 1																	
	CONFIGURE UTILITY												HW ALTERNATE SEQUENCE ENABLE				
PRI	01	02	03	04	05	06	07	08	09	10	11	12	13	14	15	16	
BC																	
R1																	
R2																	
R3																	
R4																	

Sequence 2																
PRI	01	02	03	04	05	06	07	08	09	10	11	12	13	14	15	16
BC																
R1																
R2																
R3																
R4																

Sequence 3																
PRI	01	02	03	04	05	06	07	08	09	10	11	12	13	14	15	16
BC																
R1																
R2																
R3																
R4																

Sequence 4																
PRI	01	02	03	04	05	06	07	08	09	10	11	12	13	14	15	16
BC																
R1																
R2																
R3																
R4																

Sequence 5																
PRI	01	02	03	04	05	06	07	08	09	10	11	12	13	14	15	16
BC																
R1																
R2																
R3																
R4																

Sequence 6																
PRI	01	02	03	04	05	06	07	08	09	10	11	12	13	14	15	16
BC																
R1																
R2																
R3																
R4																

Sequence 7																
PRI	01	02	03	04	05	06	07	08	09	10	11	12	13	14	15	16
BC																
R1																
R2																
R3																
R4																

Sequence 8																
PRI	01	02	03	04	05	06	07	08	09	10	11	12	13	14	15	16
BC																
R1																
R2																
R3																
R4																

▪ Appendix D

Sequence 9																
PRI	01	02	03	04	05	06	07	08	09	10	11	12	13	14	15	16
BC																
R1																
R2																
R3																
R4																

Sequence 10																
PRI	01	02	03	04	05	06	07	08	09	10	11	12	13	14	15	16
BC																
R1																
R2																
R3																
R4																

Sequence 11																
PRI	01	02	03	04	05	06	07	08	09	10	11	12	13	14	15	16
BC																
R1																
R2																
R3																
R4																

Sequence 12																
PRI	01	02	03	04	05	06	07	08	09	10	11	12	13	14	15	16
BC																
R1																
R2																
R3																
R4																

Sequence 13																
PRI	01	02	03	04	05	06	07	08	09	10	11	12	13	14	15	16
BC																
R1																
R2																
R3																
R4																

Sequence 14																
PRI	01	02	03	04	05	06	07	08	09	10	11	12	13	14	15	16
BC																
R1																
R2																
R3																
R4																

Sequence 15																
PRI	01	02	03	04	05	06	07	08	09	10	11	12	13	14	15	16
BC																
R1																
R2																
R3																
R4																

Sequence 16																
PRI	01	02	03	04	05	06	07	08	09	10	11	12	13	14	15	16
BC																
R1																
R2																
R3																
R4																

▪ Appendix D

MM-1-1-2 Phase Compatibility

PHASE	16	15	14	13	12	11	10	09	08	07	06	05	04	03	02
1															
2															
3															
4															
5															
6															
7															
8															
9															
10															
11															
12															
13															
14															
15															

MM-1-2 Phases In Use / Exclusive Ped

PHASE	01	02	03	04	05	06	07	08
PHASES IN USE								
EXCLUSIVE PED								
PHASE	09	10	11	12	13	14	15	16
PHASES IN USE								
EXCLUSIVE PED								

MM-1-1-3 Enable Backup Prevent

TMG\BKUP	1	2	3	4	5	6	7	8	9	10	11	12	13	14	15	16
1	■															
2		■														
3			■													
4				■												
5					■											
6						■										
7							■									
8								■								
9									■							
10										■						
11											■					
12												■				
13													■			
14														■		
15															■	
16																■

MM-1-1-4 Simultaneous Gap

GAP\PH	1	2	3	4	5	6	7	8	9	10	11	12	13	14	15	16
1	■															
2		■														
3			■													
4				■												
5					■											
6						■										
7							■									
8								■								
9									■							
10										■						
11											■					
12												■				
13													■			
14														■		
15															■	
16																■
DISABLE																

MM-1-3 Phase-to-Load-Switch (MMU) Assignment

LOAD SWITCH	PHASE/OVERLAP 1-16	TYPE (V,P,O)	DIMMING				AUTOMATIC FLASH		
			RED	YELLOW	GREEN	DIMMING PHASE (+,-)	RED	YELLOW	FLASH TOGETHER
1									
2									
3									
4									
5									
6									
7									
8									
9									
10									
11									
12									
13									
14									
15									
16									

MM-1-4-1 SDLC Options

	BIU NUMBER							
TERM & FACILITY	1	2	3	4	5	6	7	8
ENABLE								
DETECTOR RACK	1	2	3	4	5	6	7	8
ENABLE								
ENABLE TS2 /MMU TYPE CABINET								
ENABLE MMU EXTENDED STATUS								
ENABLE SDLC STOP TIME								
ENABLE 3 CRITICAL RFEs LOCKUP								
MMU TO CU SDLC EXTERNAL START								



### MM-1-4-2 MMU Program

MMU COMPATIBILITY															
CH	16	15	14	13	12	11	10	9	8	7	6	5	4	3	2
1															
2															
3															
4															
5															
6															
7															
8															
9															
10															
11															
12															
13															
14															
15															

### MM-1-4-3 Color Check Enable

ENABLE COLOR CHECK DIAGNOSTICS																
MMU Channel	1	2	3	4	5	6	7	8	9	10	11	12	13	14	15	16
RED / DW																
YELLOW / PC																
GREEN / WALK																

### MM-1-4-4 Secondary Stations/Tests

SECONDARY TO SECONDARY ADDRESSING									
T&F	01	02	03	04	05	06	07	08	MMU
D/R	09	10	11	12	13	14	15	16	DIAG
ENABLE SDLC DIAGNOSTIC TEST									

▪ *Appendix D*

**MM-1-5-1 Ethernet Port Configuration**

MAC ADDRESS						
CONTROLLER IP						
SUBNET MASK						
DEFAULT GATEWAY IP						
SERVER IP						
LINK SPEED / DUPLEX						
DROP-OUT TIME						

**MM-1-5-2 ASC/3 Port 2 – 2070 C50S**

ENABLE (YES/NO)		PROTOCOL	
BIT RATE		ADDRESS	
DATA BITS/PARITY/STOP BITS		GROUP ADDRESS / TDR	
DUPLEX (HALF/FULL)		SIGNAL FLAGGED (YES/NO)	
FLOW CONTROL (YES/NO)		DROP-OUT TIME	
INTERSECTION MONITOR			
MODEM SETUP STRING			
USER STRING			

**MM-1-5-3 ASC/3 Port 3A – 2070 C21S**

ENABLE (YES/NO)		PROTOCOL	
BIT RATE		ADDRESS	
DATA BITS/PARITY/STOP BITS		GROUP ADDRESS / TDR	
DUPLEX (HALF/ FULL)		SIGNAL FLAGGED (YES/NO)	
FLOW CONTROL (YES/NO)		DROP-OUT TIME	

**MM-1-5-4 ASC/3 Port 3B – 2070 C22S**

ENABLE (YES/NO)		PROTOCOL	
BIT RATE		ADDRESS	
DATA BITS/PARITY/STOP BITS		GROUP ADDRESS / TDR	
DUPLEX (HALF/ FULL)		SIGNAL FLAGGED (YES/NO)	
FLOW CONTROL (YES/NO)		DROP-OUT TIME	
RTS-CTS DELAY			
RTS TURN OFF			
EARLY RTS			

**MM-1-5-5 Global Port Parameters**

NTCIP BACKUP TIME (SECONDS)	
UDP PORT	
ETHERNET PRIORITY	
PORT 2/C50S PRIORITY	
PORT 3A/C21S PRIORITY	
PORT 3B/C22S PRIORITY	

**MM-1-5-6 ECPIP**

CONTROLLER ADDRESS									
EXPANDED SYSTEM DETECTOR ADDRESS									
SYSTEM DETECTOR ASSIGNMENT:									
SYSTEM DET	1	2	3	4	5	6	7	8	
LOCAL DET									
SYSTEM DET	9	10	11	12	13	14	15	16	
LOCAL DET									

**MM-1-6-1 Enable Event Logs**

CRITICAL RFE'S (MMU/T&F)		3 CRITICAL RFE ERRORS IN 24 HOURS	
MMU FLASH FAULTS		LOCAL FLASH FAULTS	
NON-CRITICAL RFE'S		DETECTOR ERRORS	
COORDINATION ERRORS		CONTROLLER DOWNLOAD	
PREEMPT		TSP/SCP	
POWER ON/OFF		LOW BATTERY	
ACCESS		DATA CHANGE	
ONLINE/OFFLINE			
ALARM 1		ALARM 2	
ALARM 3		ALARM 4	
ALARM 5		ALARM 6	
ALARM 7		ALARM 8	
ALARM 9		ALARM 10	
ALARM 11		ALARM 12	
ALARM 13		ALARM 14	
ALARM 15		ALARM 16	

**Program Reference Card**

---

▪ *Appendix D*

**MM-1-7-1 Administration**

ENABLE CU/CABINET INTERLOCK CRC	
CU/CABINET INTERLOCK CRC VALUE	
CU/CABINET INTERLOCK HW VALUE	
REQUEST DOWNLOAD OF PROGRAMMED DATA	
CONTROLLER DATA SUMCHECK (CRC) #	
ENABLE AUTOMATIC BACKUP TO DATAKEY	

**MM-1-7-2 Display Options**

KEY CLICK ENABLE	
BACKLIGHT ENABLE	
LED MODE	
MAIN STATUS DISPLAY MODE	
SCREEN FORMAT	

**MM-1-8-1 Logic Statement Control**

	1	2	3	4	5	6	7	8	9	10	11	12	13	14	15
LP 01-15															
LP 16-30															
LP 31-45															
LP 46-60															
LP 61-75															
LP 76-90															
LP 91-100															

MM-1-8-2 Logic Processor Statements

LOGIC GATE NUMBER				1
IF				
THEN				
ELSE				

LOGIC GATE NUMBER				2
IF				
THEN				
ELSE				

LOGIC GATE NUMBER				3
IF				
THEN				
ELSE				

LOGIC GATE NUMBER				4
IF				
THEN				
ELSE				

**Program Reference Card**

▪ *Appendix D*

LOGIC GATE NUMBER				
IF				
THEN				
ELSE				

LOGIC GATE NUMBER				
IF				
THEN				
ELSE				

LOGIC GATE NUMBER				
IF				
THEN				
ELSE				

LOGIC GATE NUMBER				
IF				
THEN				
ELSE				

LOGIC GATE NUMBER				
IF				
THEN				
ELSE				

LOGIC GATE NUMBER				
IF				
THEN				
ELSE				

LOGIC GATE NUMBER				
IF				
THEN				
ELSE				

LOGIC GATE NUMBER				
IF				
THEN				
ELSE				

## Controller Submenu

### MM-2-1 Controller Timing Data, sheet 1 of 2

TIMING PLAN _____																
PHASE	1	2	3	4	5	6	7	8	9	10	11	12	13	14	15	16
MINIMUM GREEN																
BICYCLE MINIMUM GREEN																
CONDITIONAL SERVICE MIN. GREEN																
DELAYED GREEN																
WALK																
WALK 2																
WALK MAX																
PEDESTRIAN CLEARANCE																
PEDESTRIAN CLEARANCE 2																
PEDESTRIAN CLEARANCE MAX																
PEDESTRIAN CARRY OVER																
VEHICLE EXTENSION																
VEHICLE EXTENSION 2																
MAX1																
MAX2																
MAX3																
DYNAMIC MAX																
DYNAMIC MAX STEP																
YELLOW CHANGE																
RED CLEARANCE																
RED MAX																
RED REVERT																
ACTUATIONS BEFORE GAP REDUCTION																
SECONDS PER ACTIONS ADDED TO INITIAL																
MAXIMUM ADDED INITIAL GREEN																
TIME BEFORE GAP REDUCTION																
CARS WAITING BEFORE GAP REDUCTION																
STEP TO REDUCE																
TIME TO REDUCE TO MINIMUM																
MINIMUM GAP																



MM-2-1 Controller Timing Data, sheet 2 of 2

TIMING PLAN _____																
PHASE	1	2	3	4	5	6	7	8	9	10	11	12	13	14	15	16
MINIMUM GREEN																
BICYCLE MINIMUM GREEN																
CONDITIONAL SERVICE MIN. GREEN																
DELAYED GREEN																
WALK																
WALK 2																
WALK MAX																
PEDESTRIAN CLEARANCE																
PEDESTRIAN CLEARANCE 2																
PEDESTRIAN CLEARANCE MAX																
PEDESTRIAN CARRY OVER																
VEHICLE EXTENSION																
VEHICLE EXTENSION 2																
MAX1																
MAX2																
MAX3																
DYNAMIC MAX																
DYNAMIC MAX STEP																
YELLOW CHANGE																
RED CLEARANCE																
RED MAX																
RED REVERT																
ACTUATIONS BEFORE GAP REDUCTION																
SECONDS PER ACTIONS ADDED TO INITIAL																
MAXIMUM ADDED INITIAL GREEN																
TIME BEFORE GAP REDUCTION																
CARS WAITING BEFORE GAP REDUCTION																
STEP TO REDUCE																
TIME TO REDUCE TO MINIMUM																
MINIMUM GAP																

MM-2-2 Vehicle Overlaps, sheet 1 of 6

**Other/Econolite Overlap**

TIMING VEHICLE OVERLAP (A-P)																
PHASES	1	2	3	4	5	6	7	8	9	10	11	12	13	14	15	16
INCLUDED																
PROTECT																
PED PRTC																
NO OVLP																
FLSH GRN																
LAG X PH																
LAG 2 PH																
LAG GRN			LAG YEL					LAG RED					ADV GRN			

**Normal Overlap (NTCIP)**

TIMING VEHICLE OVERLAP (A-P)																
PHASES	1	2	3	4	5	6	7	8	9	10	11	12	13	14	15	16
INCLUDED																
LAG GRN			LAG YEL					LAG RED								

**-GRN/YEL Overlap (NTCIP)**

TIMING VEHICLE OVERLAP (A-P)																
PHASES	1	2	3	4	5	6	7	8	9	10	11	12	13	14	15	16
INCLUDED																
MODIFIER																

**PPLT FYA Overlap**

TIMING VEHICLE OVERLAP (A-P)		PPLT FYA=Protected Permissive Left Turn Flashing Yellow Arrow
PROTECTED PHASE (LEFT TURN), 0-16		
PERMISSIVE PHASE (OPPOSING THRU), 0-16		
FLASHING ARROW OUTPUT ISOLATE		
FLASHING ARROW OUTPUT YELLOW PED		
FLASHING ARROW OUTPUT GREEN OVERLAP		
DELAY START OF FYA (0.0-25.5 sec.)		
DELAY START OF CLEARANCE (0.0-25.5 sec.)		
ACTION PLAN SPECIAL FUNCTION BIT DISABLE (0-8)		

MM-2-2 Vehicle Overlaps, sheet 2 of 6

**Other/Econolite Overlap**

TIMING VEHICLE OVERLAP (A-P)																
PHASES	1	2	3	4	5	6	7	8	9	10	11	12	13	14	15	16
INCLUDED																
PROTECT																
PED PRTC																
NO OVLP																
FLSH GRN																
LAG X PH																
LAG 2 PH																
LAG GRN			LAG YEL					LAG RED					ADV GRN			

**Normal Overlap (NTCIP)**

TIMING VEHICLE OVERLAP (A-P)																
PHASES	1	2	3	4	5	6	7	8	9	10	11	12	13	14	15	16
INCLUDED																
LAG GRN			LAG YEL					LAG RED								

**-GRN/YEL Overlap (NTCIP)**

TIMING VEHICLE OVERLAP (A-P)																
PHASES	1	2	3	4	5	6	7	8	9	10	11	12	13	14	15	16
INCLUDED																
MODIFIER																

**PPLT FYA Overlap**

TIMING VEHICLE OVERLAP (A-P)		PPLT FYA=Protected Permissive Left Turn Flashing Yellow Arrow
PROTECTED PHASE (LEFT TURN), 0-16		
PERMISSIVE PHASE (OPPOSING THRU), 0-16		
FLASHING ARROW OUTPUT ISOLATE		
FLASHING ARROW OUTPUT YELLOW PED		
FLASHING ARROW OUTPUT GREEN OVERLAP		
DELAY START OF FYA (0.0-25.5 sec.)		
DELAY START OF CLEARANCE (0.0-25.5 sec.)		
ACTION PLAN SPECIAL FUNCTION BIT DISABLE (0-8)		

MM-2-2 Vehicle Overlaps, sheet 3 of 6

**Other/Econolite Overlap**

TIMING VEHICLE OVERLAP (A-P)																
PHASES	1	2	3	4	5	6	7	8	9	10	11	12	13	14	15	16
INCLUDED																
PROTECT																
PED PRTC																
NO OVLP																
FLSH GRN																
LAG X PH																
LAG 2 PH																
LAG GRN			LAG YEL					LAG RED					ADV GRN			

**Normal Overlap (NTCIP)**

TIMING VEHICLE OVERLAP (A-P)																
PHASES	1	2	3	4	5	6	7	8	9	10	11	12	13	14	15	16
INCLUDED																
LAG GRN			LAG YEL					LAG RED								

**-GRN/YEL Overlap (NTCIP)**

TIMING VEHICLE OVERLAP (A-P)																
PHASES	1	2	3	4	5	6	7	8	9	10	11	12	13	14	15	16
INCLUDED																
MODIFIER																

**PPLT FYA Overlap**

TIMING VEHICLE OVERLAP (A-P)		PPLT FYA=Protected Permissive Left Turn Flashing Yellow Arrow
PROTECTED PHASE (LEFT TURN), 0-16		
PERMISSIVE PHASE (OPPOSING THRU), 0-16		
FLASHING ARROW OUTPUT ISOLATE		
FLASHING ARROW OUTPUT YELLOW PED		
FLASHING ARROW OUTPUT GREEN OVERLAP		
DELAY START OF FYA (0.0-25.5 sec.)		
DELAY START OF CLEARANCE (0.0-25.5 sec.)		
ACTION PLAN SPECIAL FUNCTION BIT DISABLE (0-8)		

MM-2-2 Vehicle Overlaps, sheet 4 of 6

**Other/Econolite Overlap**

TIMING VEHICLE OVERLAP (A-P)																
PHASES	1	2	3	4	5	6	7	8	9	10	11	12	13	14	15	16
INCLUDED																
PROTECT																
PED PRTC																
NO OVLP																
FLSH GRN																
LAG X PH																
LAG 2 PH																
LAG GRN			LAG YEL					LAG RED					ADV GRN			

**Normal Overlap (NTCIP)**

TIMING VEHICLE OVERLAP (A-P)																
PHASES	1	2	3	4	5	6	7	8	9	10	11	12	13	14	15	16
INCLUDED																
LAG GRN			LAG YEL					LAG RED								

**-GRN/YEL Overlap (NTCIP)**

TIMING VEHICLE OVERLAP (A-P)																
PHASES	1	2	3	4	5	6	7	8	9	10	11	12	13	14	15	16
INCLUDED																
MODIFIER																

**PPLT FYA Overlap**

TIMING VEHICLE OVERLAP (A-P)		PPLT FYA=Protected Permissive Left Turn Flashing Yellow Arrow
PROTECTED PHASE (LEFT TURN), 0-16		
PERMISSIVE PHASE (OPPOSING THRU), 0-16		
FLASHING ARROW OUTPUT ISOLATE		
FLASHING ARROW OUTPUT YELLOW PED		
FLASHING ARROW OUTPUT GREEN OVERLAP		
DELAY START OF FYA (0.0-25.5 sec.)		
DELAY START OF CLEARANCE (0.0-25.5 sec.)		
ACTION PLAN SPECIAL FUNCTION BIT DISABLE (0-8)		

MM-2-2 Vehicle Overlaps, sheet 5 of 6

**Other/Econolite Overlap**

TIMING VEHICLE OVERLAP (A-P)																
PHASES	1	2	3	4	5	6	7	8	9	10	11	12	13	14	15	16
INCLUDED																
PROTECT																
PED PRTC																
NO OVLP																
FLSH GRN																
LAG X PH																
LAG 2 PH																
LAG GRN			LAG YEL					LAG RED					ADV GRN			

**Normal Overlap (NTCIP)**

TIMING VEHICLE OVERLAP (A-P)																
PHASES	1	2	3	4	5	6	7	8	9	10	11	12	13	14	15	16
INCLUDED																
LAG GRN			LAG YEL					LAG RED								

**-GRN/YEL Overlap (NTCIP)**

TIMING VEHICLE OVERLAP (A-P)																
PHASES	1	2	3	4	5	6	7	8	9	10	11	12	13	14	15	16
INCLUDED																
MODIFIER																

**PPLT FYA Overlap**

TIMING VEHICLE OVERLAP (A-P)		PPLT FYA=Protected Permissive Left Turn Flashing Yellow Arrow
PROTECTED PHASE (LEFT TURN), 0-16		
PERMISSIVE PHASE (OPPOSING THRU), 0-16		
FLASHING ARROW OUTPUT ISOLATE		
FLASHING ARROW OUTPUT YELLOW PED		
FLASHING ARROW OUTPUT GREEN OVERLAP		
DELAY START OF FYA (0.0-25.5 sec.)		
DELAY START OF CLEARANCE (0.0-25.5 sec.)		
ACTION PLAN SPECIAL FUNCTION BIT DISABLE (0-8)		

MM-2-2 Vehicle Overlaps, sheet 6 of 6

**Other/Econolite Overlap**

TIMING VEHICLE OVERLAP (A-P)																
PHASES	1	2	3	4	5	6	7	8	9	10	11	12	13	14	15	16
INCLUDED																
PROTECT																
PED PRTC																
NO OVLP																
FLSH GRN																
LAG X PH																
LAG 2 PH																
LAG GRN			LAG YEL					LAG RED					ADV GRN			

**Normal Overlap (NTCIP)**

TIMING VEHICLE OVERLAP (A-P)																
PHASES	1	2	3	4	5	6	7	8	9	10	11	12	13	14	15	16
INCLUDED																
LAG GRN			LAG YEL					LAG RED								

**-GRN/YEL Overlap (NTCIP)**

TIMING VEHICLE OVERLAP (A-P)																
PHASES	1	2	3	4	5	6	7	8	9	10	11	12	13	14	15	16
INCLUDED																
MODIFIER																

**PPLT FYA Overlap**

TIMING VEHICLE OVERLAP (A-P)		PPLT FYA=Protected Permissive Left Turn Flashing Yellow Arrow
PROTECTED PHASE (LEFT TURN), 0-16		
PERMISSIVE PHASE (OPPOSING THRU), 0-16		
FLASHING ARROW OUTPUT ISOLATE		
FLASHING ARROW OUTPUT YELLOW PED		
FLASHING ARROW OUTPUT GREEN OVERLAP		
DELAY START OF FYA (0.0-25.5 sec.)		
DELAY START OF CLEARANCE (0.0-25.5 sec.)		
ACTION PLAN SPECIAL FUNCTION BIT DISABLE (0-8)		

▪ Appendix D

MM-2-3 Veh/Ped Overlaps

VEH OL/PHASES	1	2	3	4	5	6	7	8	9	10	11	12	13	14	15	16
VEH OVERLAP A																
VEH OVERLAP B																
VEH OVERLAP C																
VEH OVERLAP D																
VEH OVERLAP E																
VEH OVERLAP F																
VEH OVERLAP G																
VEH OVERLAP H																
VEH OVERLAP I																
VEH OVERLAP J																
VEH OVERLAP K																
VEH OVERLAP L																
VEH OVERLAP M																
VEH OVERLAP N																
VEH OVERLAP O																
VEH OVERLAP P																
PED OL/PHASES	1	2	3	4	5	6	7	8	9	10	11	12	13	14	15	16
PED OVERLAP 1																
PED OVERLAP 2																
PED OVERLAP 3																
PED OVERLAP 4																
PED OVERLAP 5																
PED OVERLAP 6																
PED OVERLAP 7																
PED OVERLAP 8																
PED OVERLAP 9																
PED OVERLAP 10																
PED OVERLAP 11																
PED OVERLAP 12																
PED OVERLAP 13																
PED OVERLAP 14																
PED OVERLAP 15																
PED OVERLAP 16																



MM-2-4 Guaranteed Minimum Times

OL/PHASE	A01	B02	C03	D04	E05	F06	G07	H08
MIN GRN								
WALK								
PED CLR								
YELLOW								
RED CLR								
OVL GRN								
OL/PHASE	I09	J10	K11	L12	M13	N14	O15	P16
MIN GRN								
WALK								
PED CLR								
YELLOW								
RED CLR								
OVL GRN								

MM-2-5 Start/Flash Data

START UP																
	1	2	3	4	5	6	7	8	9	10	11	12	13	14	15	16
PHASE																
	A	B	C	D	E	F	G	H	I	J	K	L	M	N	O	P
OVERLAP																
FLASH>MON.				FLASH TIME								ALL RED TIME				
PWR START SEQ.				MUTCD								Y->G				
AUTOMATIC FLASH																
PHASE	1	2	3	4	5	6	7	8	9	10	11	12	13	14	15	16
ENTRY																
EXIT																
OVERLAP	A	B	C	D	E	F	G	H	I	J	K	L	M	N	O	P
EXIT																
FLASH>MON.				EXIT FLASH								MIN FLASH				
MINIMUM RECALL												CYCLE THROUGH PHASES				

**MM-2-6-1 Controller Options**

PEDESTRIAN CLEARANCE PROTECT																
MUTCD 3 SECONDS DONT WALK																
PHASE	1	2	3	4	5	6	7	8	9	10	11	12	13	14	15	16
FLASHING GRN PH																
GUAR PASSAGE																
NON-ACT I																
NON ACT II																
DUAL ENTRY																
COND SERVICE																
COND RESERVICE																
PED RESERVICE																
REST IN WALK																
FLASHING WALK																
PED CLEAR > YELLOW																
PED CLEAR > ALL RED																
INIT GRN + VEH EXT																

**MM-2-7 Pre-Timed Mode**

ENABLE PRE-TIMED OPERATION																
FREE INPUT ENABLES PRE-TIMED																
PHASE	1	2	3	4	5	6	7	8	9	10	11	12	13	14	15	16
PRETIMED																

MM-2-8 Phase Recall Options

TIMING PLAN NUMBER [1]																
PHASE	1	2	3	4	5	6	7	8	9	10	11	12	13	14	15	16
LOCK DET INPUT																
VEH RECALL																
PED RECALL																
MAX TIME RECALL																
SOFT RECALL																
NO REST IN PHASE																
ADDED INIT CALC																
TIMING PLAN NUMBER [2]																
PHASE	1	2	3	4	5	6	7	8	9	10	11	12	13	14	15	16
LOCK DET INPUT																
VEH RECALL																
PED RECALL																
MAX TIME RECALL																
SOFT RECALL																
NO REST IN PHASE																
ADDED INIT CALC																
TIMING PLAN NUMBER [3]																
PHASE	1	2	3	4	5	6	7	8	9	10	11	12	13	14	15	16
LOCK DET INPUT																
VEH RECALL																
PED RECALL																
MAX TIME RECALL																
SOFT RECALL																
NO REST IN PHASE																
ADDED INIT CALC																
TIMING PLAN NUMBER [4]																
PHASE	1	2	3	4	5	6	7	8	9	10	11	12	13	14	15	16
LOCK DET INPUT																
VEH RECALL																
PED RECALL																
MAX TIME RECALL																
SOFT RECALL																
NO REST IN PHASE																
ADDED INIT CALC																

## Coordinator Submenu

### MM-3-1 Coordinator Options

COORD OPTIONS			
MANUAL PATTERN		ECPI COORD	
SYSTEM SOURCE		SYSTEM FORMAT	
SPLITS IN		OFFSET IN	
TRANSITION		MAX SELECT	
DWELL/ADD TIME		ENABLE MAN SYNC	
DLY COORD WK-LZ		FORCE OFF	
OFFSET REF		CAL USE PED TM	
PED RECALL		PED RESERVE	
LOCAL ZERO OVRD		FO ADD INI GRN	
RE-SYNC COUNT		MULTISYNC	





MM-3-3 Split Pattern, sheet 1 of 4

SPLIT PATTERN NUMBER																	
PHASE		1		2		3		4		5		6		7		8	
SPLIT																	
PHASE		9		10		11		12		13		14		15		16	
SPLIT																	
PHASE		1	2	3	4	5	6	7	8	9	10	11	12	13	14	15	16
COORD																	
VEH RECALL																	
PED RECALL																	
MAX RECALL																	
OMIT																	

SPLIT PATTERN NUMBER																	
PHASE		1		2		3		4		5		6		7		8	
SPLIT																	
PHASE		9		10		11		12		13		14		15		16	
SPLIT																	
PHASE		1	2	3	4	5	6	7	8	9	10	11	12	13	14	15	16
COORD																	
VEH RECALL																	
PED RECALL																	
MAX RECALL																	
OMIT																	

MM-3-3 Split Pattern, sheet 2 of 4

SPLIT PATTERN NUMBER																	
PHASE		1		2		3		4		5		6		7		8	
SPLIT																	
PHASE																	
PHASE		9		10		11		12		13		14		15		16	
SPLIT																	
PHASE																	
PHASE		1	2	3	4	5	6	7	8	9	10	11	12	13	14	15	16
COORD																	
VEH RECALL																	
PED RECALL																	
MAX RECALL																	
OMIT																	

SPLIT PATTERN NUMBER																	
PHASE		1		2		3		4		5		6		7		8	
SPLIT																	
PHASE																	
PHASE		9		10		11		12		13		14		15		16	
SPLIT																	
PHASE																	
PHASE		1	2	3	4	5	6	7	8	9	10	11	12	13	14	15	16
COORD																	
VEH RECALL																	
PED RECALL																	
MAX RECALL																	
OMIT																	



MM-3-3 Split Pattern, sheet 3 of 4

SPLIT PATTERN NUMBER																	
PHASE		1		2		3		4		5		6		7		8	
SPLIT																	
PHASE																	
PHASE		9		10		11		12		13		14		15		16	
SPLIT																	
PHASE																	
PHASE		1	2	3	4	5	6	7	8	9	10	11	12	13	14	15	16
COORD																	
VEH RECALL																	
PED RECALL																	
MAX RECALL																	
OMIT																	

SPLIT PATTERN NUMBER																	
PHASE		1		2		3		4		5		6		7		8	
SPLIT																	
PHASE																	
PHASE		9		10		11		12		13		14		15		16	
SPLIT																	
PHASE																	
PHASE		1	2	3	4	5	6	7	8	9	10	11	12	13	14	15	16
COORD																	
VEH RECALL																	
PED RECALL																	
MAX RECALL																	
OMIT																	

MM-3-3 Split Pattern, sheet 4 of 4

SPLIT PATTERN NUMBER																	
PHASE		1		2		3		4		5		6		7		8	
SPLIT																	
PHASE																	
PHASE		9		10		11		12		13		14		15		16	
SPLIT																	
PHASE																	
PHASE		1	2	3	4	5	6	7	8	9	10	11	12	13	14	15	16
COORD																	
VEH RECALL																	
PED RECALL																	
MAX RECALL																	
OMIT																	

SPLIT PATTERN NUMBER																	
PHASE		1		2		3		4		5		6		7		8	
SPLIT																	
PHASE																	
PHASE		9		10		11		12		13		14		15		16	
SPLIT																	
PHASE																	
PHASE		1	2	3	4	5	6	7	8	9	10	11	12	13	14	15	16
COORD																	
VEH RECALL																	
PED RECALL																	
MAX RECALL																	
OMIT																	

*MM-3-4 Auto Permissive Minimum Green Time*

PHASE	1	2	3	4	5	6	7	8
MIN GRN								
PHASE	9	10	11	12	13	14	15	16
MIN GRN								

*MM-3-5 Split Demand*

PHASE	1	2	3	4	5	6	7	8	9	10	11	12	13	14	15	16
DEMAND 1																
DEMAND 2																
DEMAND			1		2											
DETECTOR																
CALL TIME (SEC)																
CYCLE COUNT																

## Preemptor Submenu

### MM-4-1 Preemptor, sheet 1 of 2

PREEMPTOR NUMBER																
VEH/PED	1	2	3	4	5	6	7	8	9	10	11	12	13	14	15	16
OVERLAP	A	B	C	D	E	F	G	H	I	J	K	L	M	N	O	P
TRACKCLR V																
TRACKCLR O																
ENA TRL																
DWEL VEH																
DWEL PED																
DWEL OLP																
CYC VEH																
CYC PED																
CYC OLP																
EXIT PH																
EXIT CAL																
SP FUNC																
ENABLE				PREEMPTION OVERRIDE						INTERLOCK ENABLE						
NON-LOCK INPUT				DELAY TIME (SECONDS)						INHIBIT TIME (SECONDS)						
AUTOMATIC FLASH HAS PRIORITY				DURATION TIME (SECONDS)						RED CLEAR GOES GREEN						
TERMINATE OVERLAPS ASAP				PED CLEAR THRU YELLOW						TERM PH						
PED DARK				TRACK CLEARANCE RESERVICE						DWELL FL						
LINKED PREEMPTOR				FLASH EXIT COLOR						PREEMPTION EXIT OPTION						
EXIT TIMING PLAN				RESERVICE TIME												
FREE DURING PREEMPTION	RING 1			RING 2			RING 3			RING 4						
TIMING	WALK			PED CLEAR			MIN GREEN			YELLOW			RED			
ENTRANCE MIN TIMES																
	MIN GREEN			EXT GREEN			MAX GREEN			YELLOW			RED			
TRACK CLEAR																
	MIN DWELL			PMT EXT			MAX TIME			YELLOW			RED			
DWELL/CYCLE - EXIT																
PREEMPTOR ACTIVE OUT							PREEMPTOR ACTIVE OUT IN DWELL									
OTHER PRIORITY PREEMPTOR OUT							NON-PRIORITY PREEMPTOR OUT									
INHIBIT EXTENSION TIME							PEDESTRIAN PRIORITY RETURN EXIT OPTION									
VEHICLE PRIORITY RETURN EXIT OPTION							QUEUE DELAY RECOVERY OPTION									
CONDITIONAL DELAY ENTRANCE OPTION																
PHASES	1	2	3	4	5	6	7	8	9	10	11	12	13	14	15	16
PRIORITY RTN GRN %																

MM-4-1 Preemptor, sheet 2 of 2

PREEMPTOR NUMBER																
VEH/PED	1	2	3	4	5	6	7	8	9	10	11	12	13	14	15	16
OVERLAP	A	B	C	D	E	F	G	H	I	J	K	L	M	N	O	P
TRACKCLR V																
TRACKCLR O																
ENA TRL																
DWEL VEH																
DWEL PED																
DWEL OLP																
CYC VEH																
CYC PED																
CYC OLP																
EXIT PH																
EXIT CAL																
SP FUNC																
ENABLE				PREEMPTION OVERRIDE								INTERLOCK ENABLE				
NON-LOCK INPUT				DELAY TIME (SECONDS)								INHIBIT TIME (SECONDS)				
AUTOMATIC FLASH HAS PRIORITY				DURATION TIME (SECONDS)								RED CLEAR GOES GREEN				
TERMINATE OVERLAPS ASAP				PED CLEAR THRU YELLOW								TERM PH				
PED DARK				TRACK CLEARANCE RESERVICE								DWELL FL				
LINKED PREEMPTOR				FLASH EXIT COLOR								PREEMPTION EXIT OPTION				
EXIT TIMING PLAN				RESERVICE TIME												
FREE DURING PREEMPTION	RING 1				RING 2				RING 3				RING 4			
TIMING	WALK		PED CLEAR		MIN GREEN		YELLOW		RED							
ENTRANCE MIN TIMES																
	MIN GREEN		EXT GREEN		MAX GREEN		YELLOW		RED							
TRACK CLEAR																
	MIN DWELL		PMT EXT		MAX TIME		YELLOW		RED							
DWELL/CYCLE - EXIT																
PREEMPTOR ACTIVE OUT									PREEMPTOR ACTIVE OUT IN DWELL							
OTHER PRIORITY PREEMPTOR OUT									NON-PRIORITY PREEMPTOR OUT							
INHIBIT EXTENSION TIME									PEDESTRIAN PRIORITY RETURN EXIT OPTION							
VEHICLE PRIORITY RETURN EXIT OPTION									QUEUE DELAY RECOVERY OPTION							
CONDITIONAL DELAY ENTRANCE OPTION																
PHASES	1	2	3	4	5	6	7	8	9	10	11	12	13	14	15	16
PRIORITY RTN GRN %																

**MM-4-2 Low Priority Preemptor Selection**

ENABLE PREEMPT FILTERING & TSP/SCP		
FILTERED INPUT	SOLID	PULSING
1		
2		
3		
4		
5		
6		
7		
8		
9		
10		

**MM-4-3 TSP/SCP Plan (Optional)**

TSP/SCP PLAN	1	2	3	4	5	6
TSP/SCP ENABLED						
SIGNAL TYPE (S or P)						
DETECTOR LOCK						
DELAY TIME						
MAX PRESENCE						
PREEMPT ENABLES RESERVICE						
NO DELAY IN TSP PHASES						
ACTION SPECIAL FUNCTION INHIBIT						
RESERVICE CYCLES						
BUS HEADING (NB, SB, EB, WB)						
MODE (TSP or SCP)		FREE DEFAULT PTN				
HEADWAY ALLOWANCE						

---- TSP/SCP PHASE ----																
VEH/PED	1	2	3	4	5	6	7	8	9	10	11	12	13	14	15	16
TSP/SCP1																
TSP/SCP2																
TSP/SCP3																
TSP/SCP4																
TSP/SCP5																
TSP/SCP6																

*MM-4-4 TSP/SCP Split Pattern (Optional)*

TSP/SCP SPLIT PATTERN									
PHASE	1	2	3	4	5	6	7	8	
MAX REDUCTION									
MIN GREEN	(computed automatically)								
MAX EXTENSION									
PHASE	9	10	11	12	13	14	15	16	
MAX REDUCTION									
MIN GREEN	(computed automatically)								
MAX EXTENSION									

## Time Base Submenu

### MM-5-1 Clock/Calendar Data

Are the Date and Time set OK? (Yes, No)		STANDARD TIME FROM GMT	
MANUAL ACTION PLAN		SYNC REFERENCE	
SYNC REFERENCE TIME		DAYLIGHT SAVINGS	
TIME RESET INPUT TIME SET			

### MM-5-2 Action Plan, sheet 1 of 4

ACTION PLAN																	
PATTERN									SYSTEM OVERRIDE								
TIMING PLAN									SEQUENCE								
VEHICLE DETECTOR PLAN									DETECTOR LOG								
FLASH									RED REST								
VEHICLE DET DIAGNOSTIC PLAN									PED DET DIAGNOSTIC PLAN								
DIMMING ENABLE																	
PHASE	1	2	3	4	5	6	7	8	9	10	11	12	13	14	15	16	
PED RECALL																	
WALK 2																	
VEH EXT 2																	
VEH RECALL																	
MAX RECALL																	
MAX 2																	
MAX 3																	
CS INHIBIT																	
PHASE OMIT																	
SPEC FUNCTION																(1-8)	
AUX FUNCTION					(1-3)												
	1	2	3	4	5	6	7	8	9	10	11	12	13	14	15		
LP 1-15																	
LP 16-30																	
LP 31-45																	
LP 46-60																	
LP 61-75																	
LP 76-90																	
LP 91-100																	



MM-5-2 Action Plan, sheet 2 of 4

ACTION PLAN																
PATTERN								SYSTEM OVERRIDE								
TIMING PLAN								SEQUENCE								
VEHICLE DETECTOR PLAN								DETECTOR LOG								
FLASH								RED REST								
VEHICLE DET DIAGNOSTIC PLAN								PED DET DIAGNOSTIC PLAN								
DIMMING ENABLE																
PHASE	1	2	3	4	5	6	7	8	9	10	11	12	13	14	15	16
PED RECALL																
WALK 2																
VEH EXT 2																
VEH RECALL																
MAX RECALL																
MAX 2																
MAX 3																
CS INHIBIT																
PHASE OMIT																
SPEC FUNCTION									(1-8)							
AUX FUNCTION				(1-3)												
	1	2	3	4	5	6	7	8	9	10	11	12	13	14	15	
LP 1-15																
LP 16-30																
LP 31-45																
LP 46-60																
LP 61-75																
LP 76-90																
LP 91-100																

**Program Reference Card**

▪ *Appendix D*

**MM-5-2 Action Plan, sheet 3 of 4**

ACTION PLAN																
PATTERN		SYSTEM OVERRIDE														
TIMING PLAN		SEQUENCE														
VEHICLE DETECTOR PLAN		DETECTOR LOG														
FLASH		RED REST														
VEHICLE DET DIAGNOSTIC PLAN		PED DET DIAGNOSTIC PLAN														
DIMMING ENABLE																
<b>PHASE</b>	<b>1</b>	<b>2</b>	<b>3</b>	<b>4</b>	<b>5</b>	<b>6</b>	<b>7</b>	<b>8</b>	<b>9</b>	<b>10</b>	<b>11</b>	<b>12</b>	<b>13</b>	<b>14</b>	<b>15</b>	<b>16</b>
PED RECALL																
WALK 2																
VEH EXT 2																
VEH RECALL																
MAX RECALL																
MAX 2																
MAX 3																
CS INHIBIT																
PHASE OMIT																
SPEC FUNCTION																
AUX FUNCTION																
	<b>1</b>	<b>2</b>	<b>3</b>	<b>4</b>	<b>5</b>	<b>6</b>	<b>7</b>	<b>8</b>	<b>9</b>	<b>10</b>	<b>11</b>	<b>12</b>	<b>13</b>	<b>14</b>	<b>15</b>	
LP 1-15																
LP 16-30																
LP 31-45																
LP 46-60																
LP 61-75																
LP 76-90																
LP 91-100																

MM-5-2 Action Plan, sheet 4 of 4

ACTION PLAN																
PATTERN																
TIMING PLAN																
VEHICLE DETECTOR PLAN																
FLASH																
VEHICLE DET DIAGNOSTIC PLAN																
DIMMING ENABLE																
PHASE	1	2	3	4	5	6	7	8	9	10	11	12	13	14	15	16
PED RECALL																
WALK 2																
VEH EXT 2																
VEH RECALL																
MAX RECALL																
MAX 2																
MAX 3																
CS INHIBIT																
PHASE OMIT																
SPEC FUNCTION																(1-8)
AUX FUNCTION																(1-3)
	1	2	3	4	5	6	7	8	9	10	11	12	13	14	15	
LP 1-15																
LP 16-30																
LP 31-45																
LP 46-60																
LP 61-75																
LP 76-90																
LP 91-100																

MM-5-3 Day Plan, sheet 1 of 2

DAY PLAN #					
EVENT #	ACTION PLAN #	START TIME	EVENT #	ACTION PLAN #	START TIME
1		:	26		:
2		:	27		:
3		:	28		:
4		:	29		:
5		:	30		:
6		:	31		:
7		:	32		:
8		:	33		:
9		:	34		:
10		:	35		:
11		:	36		:
12		:	37		:
13		:	38		:
14		:	39		:
15		:	40		:
16		:	41		:
17		:	42		:
18		:	43		:
19		:	44		:
20		:	45		:
21		:	46		:
22		:	47		:
23		:	48		:
24		:	49		:
25		:	50		:

MM-5-3 Day Plan, sheet 2 of 2

DAY PLAN #						
EVENT #	ACTION PLAN #	START TIME		EVENT #	ACTION PLAN #	START TIME
1		:		26		:
2		:		27		:
3		:		28		:
4		:		29		:
5		:		30		:
6		:		31		:
7		:		32		:
8		:		33		:
9		:		34		:
10		:		35		:
11		:		36		:
12		:		37		:
13		:		38		:
14		:		39		:
15		:		40		:
16		:		41		:
17		:		42		:
18		:		43		:
19		:		44		:
20		:		45		:
21		:		46		:
22		:		47		:
23		:		48		:
24		:		49		:
25		:		50		:

**Program Reference Card**

▪ Appendix D

**MM-5-4 Schedule, sheet 1 of 3**

SCHEDULE NUMBER													
DAY PLAN NUMBER													
MONTH	J	F	M	A	M	J	J	A	S	O	N	D	
DAY OF WEEK (DOW)	SUN		MON		TUE		WED		THU		FRI		SAT
DAY OF MONTH (DOM)	1	2	3	4	5	6	7	8	9	10	11		
	12	13	14	15	16	17	18	19	20	21	22		
	23	24	25	26	27	28	29	30	31				

SCHEDULE NUMBER													
DAY PLAN NUMBER													
MONTH	J	F	M	A	M	J	J	A	S	O	N	D	
DAY OF WEEK (DOW)	SUN		MON		TUE		WED		THU		FRI		SAT
DAY OF MONTH (DOM)	1	2	3	4	5	6	7	8	9	10	11		
	12	13	14	15	16	17	18	19	20	21	22		
	23	24	25	26	27	28	29	30	31				

MM-5-4 Schedule, sheet 2 of 3

SCHEDULE NUMBER												
DAY PLAN NUMBER												
MONTH	J	F	M	A	M	J	J	A	S	O	N	D
DAY OF WEEK (DOW)	SUN		MON	TUE		WED		THU	FRI		SAT	
DAY OF MONTH (DOM)	1	2	3	4	5	6	7	8	9	10	11	
	12	13	14	15	16	17	18	19	20	21	22	
	23	24	25	26	27	28	29	30	31			

SCHEDULE NUMBER												
DAY PLAN NUMBER												
MONTH	J	F	M	A	M	J	J	A	S	O	N	D
DAY OF WEEK (DOW)	SUN		MON	TUE		WED		THU	FRI		SAT	
DAY OF MONTH (DOM)	1	2	3	4	5	6	7	8	9	10	11	
	12	13	14	15	16	17	18	19	20	21	22	
	23	24	25	26	27	28	29	30	31			

**Program Reference Card**

▪ *Appendix D*

**MM-5-4 Schedule, sheet 3 of 3**

SCHEDULE NUMBER													
DAY PLAN NUMBER													
MONTH	J	F	M	A	M	J	J	A	S	O	N	D	
DAY OF WEEK (DOW)	SUN		MON		TUE		WED		THU		FRI		SAT
DAY OF MONTH (DOM)	1	2	3	4	5	6	7	8	9	10	11		
	12	13	14	15	16	17	18	19	20	21	22		
	23	24	25	26	27	28	29	30	31				

SCHEDULE NUMBER													
DAY PLAN NUMBER													
MONTH	J	F	M	A	M	J	J	A	S	O	N	D	
DAY OF WEEK (DOW)	SUN		MON		TUE		WED		THU		FRI		SAT
DAY OF MONTH (DOM)	1	2	3	4	5	6	7	8	9	10	11		
	12	13	14	15	16	17	18	19	20	21	22		
	23	24	25	26	27	28	29	30	31				



MM-5-5 Exception Day Program

EXCEPTION DAY	FLOAT / FIXED	MON / MON	DOW / DOM	WOM / YEAR	DAY PLAN
1					
2					
3					
4					
5					
6					
7					
8					
9					
10					
11					
12					
13					
14					
15					
16					
17					
18					
19					
20					
21					
22					
23					
24					
25					
26					
27					
28					
29					
30					
31					
32					
33					
34					
35					
36					

▪ Appendix D

## Detector Submenu

MM-6-1 Vehicle Detector Assignment, sheet 1 of 2

VEHICLE DETECTOR PLAN NUMBER [ ]																		
DET	PH	1	2	3	4	5	6	7	8	9	10	11	12	13	14	15	16	T (TYPE)
1																		
2																		
3																		
4																		
5																		
6																		
7																		
8																		
9																		
10																		
11																		
12																		
13																		
14																		
15																		
16																		
17																		
18																		
19																		
20																		
21																		
22																		
23																		
24																		
25																		
26																		
27																		
28																		
29																		
30																		
31																		
32																		
33																		
34																		
35																		
36																		
37																		
38																		
39																		
40																		
41																		
42																		
43																		
44																		
45																		
46																		
47																		
48																		
49																		
50																		
51																		
52																		
53																		
54																		
55																		
56																		
57																		
58																		
59																		
60																		
61																		
62																		
63																		
64																		

MM-6-1 Vehicle Detector Assignment, sheet 2 of 2

VEHICLE DETECTOR PLAN NUMBER [ ]																		
DET	PH	1	2	3	4	5	6	7	8	9	10	11	12	13	14	15	16	T (TYPE)
1																		
2																		
3																		
4																		
5																		
6																		
7																		
8																		
9																		
10																		
11																		
12																		
13																		
14																		
15																		
16																		
17																		
18																		
19																		
20																		
21																		
22																		
23																		
24																		
25																		
26																		
27																		
28																		
29																		
30																		
31																		
32																		
33																		
34																		
35																		
36																		
37																		
38																		
39																		
40																		
41																		
42																		
43																		
44																		
45																		
46																		
47																		
48																		
49																		
50																		
51																		
52																		
53																		
54																		
55																		
56																		
57																		
58																		
59																		
60																		
61																		
62																		
63																		
64																		

**Program Reference Card**

▪ Appendix D

**MM-6-2 Vehicle Detector Setup, sheet 1 of 16**

<b>General Detector Parameters — Note: Enter DET PH in MM-6-1.</b>																	
VEHICLE DETECTOR NUMBER (1-64)							VEHICLE DETECTOR PLAN NUMBER (1-4)										
DETECTOR TYPE (S, D, P, C, R, G, N, B)																	
ENABLE TS2 DETECTOR?											ENABLE ECPI LOG?						
PHASE NO.	1	2	3	4	5	6	7	8	9	10	11	12	13	14	15	16	

<b>Parameters Specific to the Detector Type — Note: There are no more parameters for type R (Red Extension).</b>			
<b>TYPE S</b>		<b>STANDARD DETECTOR PARAMETER SETTINGS</b>	
EXTEND TIME (0-25.5 SEC.)		DELAY TIME (0-255.0 SEC.)	
USE ADDED INITIAL CALCULATION		CROSS SWITCH PHASE (0-16)	
LOCK IN RED		NTCIP VOLUME	
LOCK IN YELLOW		NTCIP OCCUPANCY	PMT QUEUE DELAY
<b>TYPE D</b>		<b>DISCONNECT QUEUE/STOP BAR DETECTOR PARAMETER SETTINGS</b>	
DISCONNECT TIME (0-255 SEC.)			
USE ADDED INITIAL CALCULATION		CROSS SWITCH PHASE (0-16)	
LOCK IN RED		NTCIP VOLUME	
LOCK IN YELLOW		NTCIP OCCUPANCY	PMT QUEUE DELAY
<b>TYPE P</b>		<b>PASSAGE QUEUE/STOP BAR DETECTOR PARAMETER SETTINGS</b>	
PASSAGE EXTENSION TIME (0-255 SEC.)			
USE ADDED INITIAL CALCULATION		CROSS SWITCH PHASE (0-16)	
LOCK IN RED		NTCIP VOLUME	
LOCK IN YELLOW		NTCIP OCCUPANCY	PMT QUEUE DELAY
<b>TYPE C</b>		<b>CALLING DETECTOR PARAMETER SETTINGS</b>	
USE ADDED INITIAL CALCULATION		CROSS SWITCH PHASE (0-16)	
LOCK IN RED		NTCIP VOLUME	
LOCK IN YELLOW		NTCIP OCCUPANCY	PMT QUEUE DELAY
<b>TYPE G</b>		<b>GREEN EXTENSION/DELAY DETECTOR PARAMETER SETTINGS</b>	
EXTEND TIME (0-25.5 SEC.)		DELAY TIME (0-255.0 SEC.)	
USE ADDED INITIAL CALCULATION		CROSS SWITCH PHASE (0-16)	
LOCK IN RED		NTCIP VOLUME	
LOCK IN YELLOW		NTCIP OCCUPANCY	PMT QUEUE DELAY
<b>TYPE N</b>		<b>NTCIP DETECTOR PARAMETER SETTINGS</b>	
CALL OPTION (YES/NO)		DELAY TIME (0-255.0 SEC.)	
EXTENSION OPTION (PASSAGE)		EXTENSION TIME (0-25.5 SEC)	
EXTENSION OPTION (QUEUE)		QUEUE LIMIT (0-255 SEC.)	
USE ADDED INITIAL CALCULATION		CROSS SWITCH PHASE (0-16)	
LOCK IN RED		NTCIP VOLUME	
LOCK IN YELLOW		NTCIP OCCUPANCY	PMT QUEUE DELAY
<b>TYPE B</b>		<b>BIKE DETECTOR PARAMETER SETTINGS</b>	
EXTEND TIME (0-25.5 SEC.)		NTCIP VOLUME	
		NTCIP OCCUPANCY	

MM-6-2 Vehicle Detector Setup, sheet 2 of 16

General Detector Parameters — Note: Enter DET PH in MM-6-1.																	
VEHICLE DETECTOR NUMBER (1-64)							VEHICLE DETECTOR PLAN NUMBER (1-4)										
DETECTOR TYPE (S, D, P, C, R, G, N, B)																	
ENABLE TS2 DETECTOR?							ENABLE ECPI LOG?										
PHASE NO.	1	2	3	4	5	6	7	8	9	10	11	12	13	14	15	16	

Parameters Specific to the Detector Type — Note: There are no more parameters for type R (Red Extension).																	
<b>TYPE S</b>																	
STANDARD DETECTOR PARAMETER SETTINGS																	
EXTEND TIME (0-25.5 SEC.)							DELAY TIME (0-255.0 SEC.)										
USE ADDED INITIAL CALCULATION							CROSS SWITCH PHASE (0-16)										
LOCK IN RED							NTCIP VOLUME										
LOCK IN YELLOW				NTCIP OCCUPANCY				PMT QUEUE DELAY									
<b>TYPE D</b>																	
DISCONNECT QUEUE/STOP BAR DETECTOR PARAMETER SETTINGS																	
DISCONNECT TIME (0-255 SEC.)																	
USE ADDED INITIAL CALCULATION							CROSS SWITCH PHASE (0-16)										
LOCK IN RED							NTCIP VOLUME										
LOCK IN YELLOW				NTCIP OCCUPANCY				PMT QUEUE DELAY									
<b>TYPE P</b>																	
PASSAGE QUEUE/STOP BAR DETECTOR PARAMETER SETTINGS																	
PASSAGE EXTENSION TIME (0-255 SEC.)																	
USE ADDED INITIAL CALCULATION							CROSS SWITCH PHASE (0-16)										
LOCK IN RED							NTCIP VOLUME										
LOCK IN YELLOW				NTCIP OCCUPANCY				PMT QUEUE DELAY									
<b>TYPE C</b>																	
CALLING DETECTOR PARAMETER SETTINGS																	
USE ADDED INITIAL CALCULATION							CROSS SWITCH PHASE (0-16)										
LOCK IN RED							NTCIP VOLUME										
LOCK IN YELLOW				NTCIP OCCUPANCY				PMT QUEUE DELAY									
<b>TYPE G</b>																	
GREEN EXTENSION/DELAY DETECTOR PARAMETER SETTINGS																	
EXTEND TIME (0-25.5 SEC.)							DELAY TIME (0-255.0 SEC.)										
USE ADDED INITIAL CALCULATION							CROSS SWITCH PHASE (0-16)										
LOCK IN RED							NTCIP VOLUME										
LOCK IN YELLOW				NTCIP OCCUPANCY				PMT QUEUE DELAY									
<b>TYPE N</b>																	
NTCIP DETECTOR PARAMETER SETTINGS																	
CALL OPTION (YES/NO)							DELAY TIME (0-255.0 SEC.)										
EXTENSION OPTION (PASSAGE)							EXTENSION TIME (0-25.5 SEC)										
EXTENSION OPTION (QUEUE)							QUEUE LIMIT (0-255 SEC.)										
USE ADDED INITIAL CALCULATION							CROSS SWITCH PHASE (0-16)										
LOCK IN RED							NTCIP VOLUME										
LOCK IN YELLOW				NTCIP OCCUPANCY				PMT QUEUE DELAY									
<b>TYPE B</b>																	
BIKE DETECTOR PARAMETER SETTINGS																	
EXTEND TIME (0-25.5 SEC.)							NTCIP VOLUME										
							NTCIP OCCUPANCY										

**Program Reference Card**

▪ Appendix D

**MM-6-2 Vehicle Detector Setup, sheet 3 of 16**

<b>General Detector Parameters — Note: Enter DET PH in MM-6-1.</b>																	
VEHICLE DETECTOR NUMBER (1-64)							VEHICLE DETECTOR PLAN NUMBER (1-4)										
DETECTOR TYPE (S, D, P, C, R, G, N, B)																	
ENABLE TS2 DETECTOR?											ENABLE ECPI LOG?						
PHASE NO.	1	2	3	4	5	6	7	8	9	10	11	12	13	14	15	16	

<b>Parameters Specific to the Detector Type — Note: There are no more parameters for type R (Red Extension).</b>			
<b>TYPE S</b>		<b>STANDARD DETECTOR PARAMETER SETTINGS</b>	
EXTEND TIME (0-25.5 SEC.)		DELAY TIME (0-255.0 SEC.)	
USE ADDED INITIAL CALCULATION		CROSS SWITCH PHASE (0-16)	
LOCK IN RED		NTCIP VOLUME	
LOCK IN YELLOW		NTCIP OCCUPANCY	PMT QUEUE DELAY
<b>TYPE D</b>		<b>DISCONNECT QUEUE/STOP BAR DETECTOR PARAMETER SETTINGS</b>	
DISCONNECT TIME (0-255 SEC.)			
USE ADDED INITIAL CALCULATION		CROSS SWITCH PHASE (0-16)	
LOCK IN RED		NTCIP VOLUME	
LOCK IN YELLOW		NTCIP OCCUPANCY	PMT QUEUE DELAY
<b>TYPE P</b>		<b>PASSAGE QUEUE/STOP BAR DETECTOR PARAMETER SETTINGS</b>	
PASSAGE EXTENSION TIME (0-255 SEC.)			
USE ADDED INITIAL CALCULATION		CROSS SWITCH PHASE (0-16)	
LOCK IN RED		NTCIP VOLUME	
LOCK IN YELLOW		NTCIP OCCUPANCY	PMT QUEUE DELAY
<b>TYPE C</b>		<b>CALLING DETECTOR PARAMETER SETTINGS</b>	
USE ADDED INITIAL CALCULATION		CROSS SWITCH PHASE (0-16)	
LOCK IN RED		NTCIP VOLUME	
LOCK IN YELLOW		NTCIP OCCUPANCY	PMT QUEUE DELAY
<b>TYPE G</b>		<b>GREEN EXTENSION/DELAY DETECTOR PARAMETER SETTINGS</b>	
EXTEND TIME (0-25.5 SEC.)		DELAY TIME (0-255.0 SEC.)	
USE ADDED INITIAL CALCULATION		CROSS SWITCH PHASE (0-16)	
LOCK IN RED		NTCIP VOLUME	
LOCK IN YELLOW		NTCIP OCCUPANCY	PMT QUEUE DELAY
<b>TYPE N</b>		<b>NTCIP DETECTOR PARAMETER SETTINGS</b>	
CALL OPTION (YES/NO)		DELAY TIME (0-255.0 SEC.)	
EXTENSION OPTION (PASSAGE)		EXTENSION TIME (0-25.5 SEC)	
EXTENSION OPTION (QUEUE)		QUEUE LIMIT (0-255 SEC.)	
USE ADDED INITIAL CALCULATION		CROSS SWITCH PHASE (0-16)	
LOCK IN RED		NTCIP VOLUME	
LOCK IN YELLOW		NTCIP OCCUPANCY	PMT QUEUE DELAY
<b>TYPE B</b>		<b>BIKE DETECTOR PARAMETER SETTINGS</b>	
EXTEND TIME (0-25.5 SEC.)		NTCIP VOLUME	
		NTCIP OCCUPANCY	

MM-6-2 Vehicle Detector Setup, sheet 4 of 16

<b>General Detector Parameters — Note: Enter DET PH in MM-6-1.</b>																	
VEHICLE DETECTOR NUMBER (1-64)							VEHICLE DETECTOR PLAN NUMBER (1-4)										
DETECTOR TYPE (S, D, P, C, R, G, N, B)																	
ENABLE TS2 DETECTOR?							ENABLE ECPI LOG?										
PHASE NO.	1	2	3	4	5	6	7	8	9	10	11	12	13	14	15	16	

<b>Parameters Specific to the Detector Type — Note: There are no more parameters for type R (Red Extension).</b>																	
<b>TYPE S STANDARD DETECTOR PARAMETER SETTINGS</b>																	
EXTEND TIME (0-25.5 SEC.)							DELAY TIME (0-255.0 SEC.)										
USE ADDED INITIAL CALCULATION							CROSS SWITCH PHASE (0-16)										
LOCK IN RED							NTCIP VOLUME										
LOCK IN YELLOW				NTCIP OCCUPANCY						PMT QUEUE DELAY							
<b>TYPE D DISCONNECT QUEUE/STOP BAR DETECTOR PARAMETER SETTINGS</b>																	
DISCONNECT TIME (0-255 SEC.)																	
USE ADDED INITIAL CALCULATION							CROSS SWITCH PHASE (0-16)										
LOCK IN RED							NTCIP VOLUME										
LOCK IN YELLOW				NTCIP OCCUPANCY						PMT QUEUE DELAY							
<b>TYPE P PASSAGE QUEUE/STOP BAR DETECTOR PARAMETER SETTINGS</b>																	
PASSAGE EXTENSION TIME (0-255 SEC.)																	
USE ADDED INITIAL CALCULATION							CROSS SWITCH PHASE (0-16)										
LOCK IN RED							NTCIP VOLUME										
LOCK IN YELLOW				NTCIP OCCUPANCY						PMT QUEUE DELAY							
<b>TYPE C CALLING DETECTOR PARAMETER SETTINGS</b>																	
USE ADDED INITIAL CALCULATION							CROSS SWITCH PHASE (0-16)										
LOCK IN RED							NTCIP VOLUME										
LOCK IN YELLOW				NTCIP OCCUPANCY						PMT QUEUE DELAY							
<b>TYPE G GREEN EXTENSION/DELAY DETECTOR PARAMETER SETTINGS</b>																	
EXTEND TIME (0-25.5 SEC.)							DELAY TIME (0-255.0 SEC.)										
USE ADDED INITIAL CALCULATION							CROSS SWITCH PHASE (0-16)										
LOCK IN RED							NTCIP VOLUME										
LOCK IN YELLOW				NTCIP OCCUPANCY						PMT QUEUE DELAY							
<b>TYPE N NTCIP DETECTOR PARAMETER SETTINGS</b>																	
CALL OPTION (YES/NO)							DELAY TIME (0-255.0 SEC.)										
EXTENSION OPTION (PASSAGE)							EXTENSION TIME (0-25.5 SEC)										
EXTENSION OPTION (QUEUE)							QUEUE LIMIT (0-255 SEC.)										
USE ADDED INITIAL CALCULATION							CROSS SWITCH PHASE (0-16)										
LOCK IN RED							NTCIP VOLUME										
LOCK IN YELLOW				NTCIP OCCUPANCY						PMT QUEUE DELAY							
<b>TYPE B BIKE DETECTOR PARAMETER SETTINGS</b>																	
EXTEND TIME (0-25.5 SEC.)							NTCIP VOLUME										
							NTCIP OCCUPANCY										

**Program Reference Card**

▪ Appendix D

**MM-6-2 Vehicle Detector Setup, sheet 5 of 16**

<b>General Detector Parameters — Note: Enter DET PH in MM-6-1.</b>																	
VEHICLE DETECTOR NUMBER (1-64)							VEHICLE DETECTOR PLAN NUMBER (1-4)										
DETECTOR TYPE (S, D, P, C, R, G, N, B)																	
ENABLE TS2 DETECTOR?											ENABLE ECPI LOG?						
PHASE NO.	1	2	3	4	5	6	7	8	9	10	11	12	13	14	15	16	

<b>Parameters Specific to the Detector Type — Note: There are no more parameters for type R (Red Extension).</b>			
<b>TYPE S</b>		<b>STANDARD DETECTOR PARAMETER SETTINGS</b>	
EXTEND TIME (0-25.5 SEC.)		DELAY TIME (0-255.0 SEC.)	
USE ADDED INITIAL CALCULATION		CROSS SWITCH PHASE (0-16)	
LOCK IN RED		NTCIP VOLUME	
LOCK IN YELLOW		NTCIP OCCUPANCY	PMT QUEUE DELAY
<b>TYPE D</b>		<b>DISCONNECT QUEUE/STOP BAR DETECTOR PARAMETER SETTINGS</b>	
DISCONNECT TIME (0-255 SEC.)			
USE ADDED INITIAL CALCULATION		CROSS SWITCH PHASE (0-16)	
LOCK IN RED		NTCIP VOLUME	
LOCK IN YELLOW		NTCIP OCCUPANCY	PMT QUEUE DELAY
<b>TYPE P</b>		<b>PASSAGE QUEUE/STOP BAR DETECTOR PARAMETER SETTINGS</b>	
PASSAGE EXTENSION TIME (0-255 SEC.)			
USE ADDED INITIAL CALCULATION		CROSS SWITCH PHASE (0-16)	
LOCK IN RED		NTCIP VOLUME	
LOCK IN YELLOW		NTCIP OCCUPANCY	PMT QUEUE DELAY
<b>TYPE C</b>		<b>CALLING DETECTOR PARAMETER SETTINGS</b>	
USE ADDED INITIAL CALCULATION		CROSS SWITCH PHASE (0-16)	
LOCK IN RED		NTCIP VOLUME	
LOCK IN YELLOW		NTCIP OCCUPANCY	PMT QUEUE DELAY
<b>TYPE G</b>		<b>GREEN EXTENSION/DELAY DETECTOR PARAMETER SETTINGS</b>	
EXTEND TIME (0-25.5 SEC.)		DELAY TIME (0-255.0 SEC.)	
USE ADDED INITIAL CALCULATION		CROSS SWITCH PHASE (0-16)	
LOCK IN RED		NTCIP VOLUME	
LOCK IN YELLOW		NTCIP OCCUPANCY	PMT QUEUE DELAY
<b>TYPE N</b>		<b>NTCIP DETECTOR PARAMETER SETTINGS</b>	
CALL OPTION (YES/NO)		DELAY TIME (0-255.0 SEC.)	
EXTENSION OPTION (PASSAGE)		EXTENSION TIME (0-25.5 SEC)	
EXTENSION OPTION (QUEUE)		QUEUE LIMIT (0-255 SEC.)	
USE ADDED INITIAL CALCULATION		CROSS SWITCH PHASE (0-16)	
LOCK IN RED		NTCIP VOLUME	
LOCK IN YELLOW		NTCIP OCCUPANCY	PMT QUEUE DELAY
<b>TYPE B</b>		<b>BIKE DETECTOR PARAMETER SETTINGS</b>	
EXTEND TIME (0-25.5 SEC.)		NTCIP VOLUME	
		NTCIP OCCUPANCY	



MM-6-2 Vehicle Detector Setup, sheet 6 of 16

<b>General Detector Parameters — Note: Enter DET PH in MM-6-1.</b>																
VEHICLE DETECTOR NUMBER (1-64)							VEHICLE DETECTOR PLAN NUMBER (1-4)									
DETECTOR TYPE (S, D, P, C, R, G, N, B)																
ENABLE TS2 DETECTOR?							ENABLE ECPI LOG?									
PHASE NO.	1	2	3	4	5	6	7	8	9	10	11	12	13	14	15	16

<b>Parameters Specific to the Detector Type — Note: There are no more parameters for type R (Red Extension).</b>																
<b>TYPE S STANDARD DETECTOR PARAMETER SETTINGS</b>																
EXTEND TIME (0-25.5 SEC.)							DELAY TIME (0-255.0 SEC.)									
USE ADDED INITIAL CALCULATION							CROSS SWITCH PHASE (0-16)									
LOCK IN RED							NTCIP VOLUME									
LOCK IN YELLOW				NTCIP OCCUPANCY						PMT QUEUE DELAY						
<b>TYPE D DISCONNECT QUEUE/STOP BAR DETECTOR PARAMETER SETTINGS</b>																
DISCONNECT TIME (0-255 SEC.)																
USE ADDED INITIAL CALCULATION							CROSS SWITCH PHASE (0-16)									
LOCK IN RED							NTCIP VOLUME									
LOCK IN YELLOW				NTCIP OCCUPANCY						PMT QUEUE DELAY						
<b>TYPE P PASSAGE QUEUE/STOP BAR DETECTOR PARAMETER SETTINGS</b>																
PASSAGE EXTENSION TIME (0-255 SEC.)																
USE ADDED INITIAL CALCULATION							CROSS SWITCH PHASE (0-16)									
LOCK IN RED							NTCIP VOLUME									
LOCK IN YELLOW				NTCIP OCCUPANCY						PMT QUEUE DELAY						
<b>TYPE C CALLING DETECTOR PARAMETER SETTINGS</b>																
USE ADDED INITIAL CALCULATION							CROSS SWITCH PHASE (0-16)									
LOCK IN RED							NTCIP VOLUME									
LOCK IN YELLOW				NTCIP OCCUPANCY						PMT QUEUE DELAY						
<b>TYPE G GREEN EXTENSION/DELAY DETECTOR PARAMETER SETTINGS</b>																
EXTEND TIME (0-25.5 SEC.)							DELAY TIME (0-255.0 SEC.)									
USE ADDED INITIAL CALCULATION							CROSS SWITCH PHASE (0-16)									
LOCK IN RED							NTCIP VOLUME									
LOCK IN YELLOW				NTCIP OCCUPANCY						PMT QUEUE DELAY						
<b>TYPE N NTCIP DETECTOR PARAMETER SETTINGS</b>																
CALL OPTION (YES/NO)							DELAY TIME (0-255.0 SEC.)									
EXTENSION OPTION (PASSAGE)							EXTENSION TIME (0-25.5 SEC)									
EXTENSION OPTION (QUEUE)							QUEUE LIMIT (0-255 SEC.)									
USE ADDED INITIAL CALCULATION							CROSS SWITCH PHASE (0-16)									
LOCK IN RED							NTCIP VOLUME									
LOCK IN YELLOW				NTCIP OCCUPANCY						PMT QUEUE DELAY						
<b>TYPE B BIKE DETECTOR PARAMETER SETTINGS</b>																
EXTEND TIME (0-25.5 SEC.)							NTCIP VOLUME									
							NTCIP OCCUPANCY									

**Program Reference Card**

▪ Appendix D

**MM-6-2 Vehicle Detector Setup, sheet 7 of 16**

<b>General Detector Parameters — Note: Enter DET PH in MM-6-1.</b>																	
VEHICLE DETECTOR NUMBER (1-64)							VEHICLE DETECTOR PLAN NUMBER (1-4)										
DETECTOR TYPE (S, D, P, C, R, G, N, B)																	
ENABLE TS2 DETECTOR?											ENABLE ECPI LOG?						
PHASE NO.	1	2	3	4	5	6	7	8	9	10	11	12	13	14	15	16	

<b>Parameters Specific to the Detector Type — Note: There are no more parameters for type R (Red Extension).</b>			
<b>TYPE S</b>		<b>STANDARD DETECTOR PARAMETER SETTINGS</b>	
EXTEND TIME (0-25.5 SEC.)		DELAY TIME (0-255.0 SEC.)	
USE ADDED INITIAL CALCULATION		CROSS SWITCH PHASE (0-16)	
LOCK IN RED		NTCIP VOLUME	
LOCK IN YELLOW		NTCIP OCCUPANCY	PMT QUEUE DELAY
<b>TYPE D</b>		<b>DISCONNECT QUEUE/STOP BAR DETECTOR PARAMETER SETTINGS</b>	
DISCONNECT TIME (0-255 SEC.)			
USE ADDED INITIAL CALCULATION		CROSS SWITCH PHASE (0-16)	
LOCK IN RED		NTCIP VOLUME	
LOCK IN YELLOW		NTCIP OCCUPANCY	PMT QUEUE DELAY
<b>TYPE P</b>		<b>PASSAGE QUEUE/STOP BAR DETECTOR PARAMETER SETTINGS</b>	
PASSAGE EXTENSION TIME (0-255 SEC.)			
USE ADDED INITIAL CALCULATION		CROSS SWITCH PHASE (0-16)	
LOCK IN RED		NTCIP VOLUME	
LOCK IN YELLOW		NTCIP OCCUPANCY	PMT QUEUE DELAY
<b>TYPE C</b>		<b>CALLING DETECTOR PARAMETER SETTINGS</b>	
USE ADDED INITIAL CALCULATION		CROSS SWITCH PHASE (0-16)	
LOCK IN RED		NTCIP VOLUME	
LOCK IN YELLOW		NTCIP OCCUPANCY	PMT QUEUE DELAY
<b>TYPE G</b>		<b>GREEN EXTENSION/DELAY DETECTOR PARAMETER SETTINGS</b>	
EXTEND TIME (0-25.5 SEC.)		DELAY TIME (0-255.0 SEC.)	
USE ADDED INITIAL CALCULATION		CROSS SWITCH PHASE (0-16)	
LOCK IN RED		NTCIP VOLUME	
LOCK IN YELLOW		NTCIP OCCUPANCY	PMT QUEUE DELAY
<b>TYPE N</b>		<b>NTCIP DETECTOR PARAMETER SETTINGS</b>	
CALL OPTION (YES/NO)		DELAY TIME (0-255.0 SEC.)	
EXTENSION OPTION (PASSAGE)		EXTENSION TIME (0-25.5 SEC)	
EXTENSION OPTION (QUEUE)		QUEUE LIMIT (0-255 SEC.)	
USE ADDED INITIAL CALCULATION		CROSS SWITCH PHASE (0-16)	
LOCK IN RED		NTCIP VOLUME	
LOCK IN YELLOW		NTCIP OCCUPANCY	PMT QUEUE DELAY
<b>TYPE B</b>		<b>BIKE DETECTOR PARAMETER SETTINGS</b>	
EXTEND TIME (0-25.5 SEC.)		NTCIP VOLUME	
		NTCIP OCCUPANCY	

MM-6-2 Vehicle Detector Setup, sheet 8 of 16

<b>General Detector Parameters — Note: Enter DET PH in MM-6-1.</b>																
VEHICLE DETECTOR NUMBER (1-64)							VEHICLE DETECTOR PLAN NUMBER (1-4)									
DETECTOR TYPE (S, D, P, C, R, G, N, B)																
ENABLE TS2 DETECTOR?							ENABLE ECPI LOG?									
PHASE NO.	1	2	3	4	5	6	7	8	9	10	11	12	13	14	15	16

<b>Parameters Specific to the Detector Type — Note: There are no more parameters for type R (Red Extension).</b>																
<b>TYPE S STANDARD DETECTOR PARAMETER SETTINGS</b>																
EXTEND TIME (0-25.5 SEC.)							DELAY TIME (0-255.0 SEC.)									
USE ADDED INITIAL CALCULATION							CROSS SWITCH PHASE (0-16)									
LOCK IN RED							NTCIP VOLUME									
LOCK IN YELLOW				NTCIP OCCUPANCY				PMT QUEUE DELAY								
<b>TYPE D DISCONNECT QUEUE/STOP BAR DETECTOR PARAMETER SETTINGS</b>																
DISCONNECT TIME (0-255 SEC.)																
USE ADDED INITIAL CALCULATION							CROSS SWITCH PHASE (0-16)									
LOCK IN RED							NTCIP VOLUME									
LOCK IN YELLOW				NTCIP OCCUPANCY				PMT QUEUE DELAY								
<b>TYPE P PASSAGE QUEUE/STOP BAR DETECTOR PARAMETER SETTINGS</b>																
PASSAGE EXTENSION TIME (0-255 SEC.)																
USE ADDED INITIAL CALCULATION							CROSS SWITCH PHASE (0-16)									
LOCK IN RED							NTCIP VOLUME									
LOCK IN YELLOW				NTCIP OCCUPANCY				PMT QUEUE DELAY								
<b>TYPE C CALLING DETECTOR PARAMETER SETTINGS</b>																
USE ADDED INITIAL CALCULATION							CROSS SWITCH PHASE (0-16)									
LOCK IN RED							NTCIP VOLUME									
LOCK IN YELLOW				NTCIP OCCUPANCY				PMT QUEUE DELAY								
<b>TYPE G GREEN EXTENSION/DELAY DETECTOR PARAMETER SETTINGS</b>																
EXTEND TIME (0-25.5 SEC.)							DELAY TIME (0-255.0 SEC.)									
USE ADDED INITIAL CALCULATION							CROSS SWITCH PHASE (0-16)									
LOCK IN RED							NTCIP VOLUME									
LOCK IN YELLOW				NTCIP OCCUPANCY				PMT QUEUE DELAY								
<b>TYPE N NTCIP DETECTOR PARAMETER SETTINGS</b>																
CALL OPTION (YES/NO)							DELAY TIME (0-255.0 SEC.)									
EXTENSION OPTION (PASSAGE)							EXTENSION TIME (0-25.5 SEC)									
EXTENSION OPTION (QUEUE)							QUEUE LIMIT (0-255 SEC.)									
USE ADDED INITIAL CALCULATION							CROSS SWITCH PHASE (0-16)									
LOCK IN RED							NTCIP VOLUME									
LOCK IN YELLOW				NTCIP OCCUPANCY				PMT QUEUE DELAY								
<b>TYPE B BIKE DETECTOR PARAMETER SETTINGS</b>																
EXTEND TIME (0-25.5 SEC.)							NTCIP VOLUME									
							NTCIP OCCUPANCY									

**Program Reference Card**

▪ Appendix D

**MM-6-2 Vehicle Detector Setup, sheet 9 of 16**

<b>General Detector Parameters — Note: Enter DET PH in MM-6-1.</b>																	
VEHICLE DETECTOR NUMBER (1-64)							VEHICLE DETECTOR PLAN NUMBER (1-4)										
DETECTOR TYPE (S, D, P, C, R, G, N, B)																	
ENABLE TS2 DETECTOR?											ENABLE ECPI LOG?						
PHASE NO.	1	2	3	4	5	6	7	8	9	10	11	12	13	14	15	16	

<b>Parameters Specific to the Detector Type — Note: There are no more parameters for type R (Red Extension).</b>			
<b>TYPE S</b>		<b>STANDARD DETECTOR PARAMETER SETTINGS</b>	
EXTEND TIME (0-25.5 SEC.)		DELAY TIME (0-255.0 SEC.)	
USE ADDED INITIAL CALCULATION		CROSS SWITCH PHASE (0-16)	
LOCK IN RED		NTCIP VOLUME	
LOCK IN YELLOW		NTCIP OCCUPANCY	PMT QUEUE DELAY
<b>TYPE D</b>		<b>DISCONNECT QUEUE/STOP BAR DETECTOR PARAMETER SETTINGS</b>	
DISCONNECT TIME (0-255 SEC.)			
USE ADDED INITIAL CALCULATION		CROSS SWITCH PHASE (0-16)	
LOCK IN RED		NTCIP VOLUME	
LOCK IN YELLOW		NTCIP OCCUPANCY	PMT QUEUE DELAY
<b>TYPE P</b>		<b>PASSAGE QUEUE/STOP BAR DETECTOR PARAMETER SETTINGS</b>	
PASSAGE EXTENSION TIME (0-255 SEC.)			
USE ADDED INITIAL CALCULATION		CROSS SWITCH PHASE (0-16)	
LOCK IN RED		NTCIP VOLUME	
LOCK IN YELLOW		NTCIP OCCUPANCY	PMT QUEUE DELAY
<b>TYPE C</b>		<b>CALLING DETECTOR PARAMETER SETTINGS</b>	
USE ADDED INITIAL CALCULATION		CROSS SWITCH PHASE (0-16)	
LOCK IN RED		NTCIP VOLUME	
LOCK IN YELLOW		NTCIP OCCUPANCY	PMT QUEUE DELAY
<b>TYPE G</b>		<b>GREEN EXTENSION/DELAY DETECTOR PARAMETER SETTINGS</b>	
EXTEND TIME (0-25.5 SEC.)		DELAY TIME (0-255.0 SEC.)	
USE ADDED INITIAL CALCULATION		CROSS SWITCH PHASE (0-16)	
LOCK IN RED		NTCIP VOLUME	
LOCK IN YELLOW		NTCIP OCCUPANCY	PMT QUEUE DELAY
<b>TYPE N</b>		<b>NTCIP DETECTOR PARAMETER SETTINGS</b>	
CALL OPTION (YES/NO)		DELAY TIME (0-255.0 SEC.)	
EXTENSION OPTION (PASSAGE)		EXTENSION TIME (0-25.5 SEC)	
EXTENSION OPTION (QUEUE)		QUEUE LIMIT (0-255 SEC.)	
USE ADDED INITIAL CALCULATION		CROSS SWITCH PHASE (0-16)	
LOCK IN RED		NTCIP VOLUME	
LOCK IN YELLOW		NTCIP OCCUPANCY	PMT QUEUE DELAY
<b>TYPE B</b>		<b>BIKE DETECTOR PARAMETER SETTINGS</b>	
EXTEND TIME (0-25.5 SEC.)		NTCIP VOLUME	
		NTCIP OCCUPANCY	

MM-6-2 Vehicle Detector Setup, sheet 10 of 16

<b>General Detector Parameters — Note: Enter DET PH in MM-6-1.</b>																
VEHICLE DETECTOR NUMBER (1-64)							VEHICLE DETECTOR PLAN NUMBER (1-4)									
DETECTOR TYPE (S, D, P, C, R, G, N, B)																
ENABLE TS2 DETECTOR?							ENABLE ECPI LOG?									
PHASE NO.	1	2	3	4	5	6	7	8	9	10	11	12	13	14	15	16

<b>Parameters Specific to the Detector Type — Note: There are no more parameters for type R (Red Extension).</b>																
<b>TYPE S STANDARD DETECTOR PARAMETER SETTINGS</b>																
EXTEND TIME (0-25.5 SEC.)							DELAY TIME (0-255.0 SEC.)									
USE ADDED INITIAL CALCULATION							CROSS SWITCH PHASE (0-16)									
LOCK IN RED							NTCIP VOLUME									
LOCK IN YELLOW				NTCIP OCCUPANCY				PMT QUEUE DELAY								
<b>TYPE D DISCONNECT QUEUE/STOP BAR DETECTOR PARAMETER SETTINGS</b>																
DISCONNECT TIME (0-255 SEC.)																
USE ADDED INITIAL CALCULATION							CROSS SWITCH PHASE (0-16)									
LOCK IN RED							NTCIP VOLUME									
LOCK IN YELLOW				NTCIP OCCUPANCY				PMT QUEUE DELAY								
<b>TYPE P PASSAGE QUEUE/STOP BAR DETECTOR PARAMETER SETTINGS</b>																
PASSAGE EXTENSION TIME (0-255 SEC.)																
USE ADDED INITIAL CALCULATION							CROSS SWITCH PHASE (0-16)									
LOCK IN RED							NTCIP VOLUME									
LOCK IN YELLOW				NTCIP OCCUPANCY				PMT QUEUE DELAY								
<b>TYPE C CALLING DETECTOR PARAMETER SETTINGS</b>																
USE ADDED INITIAL CALCULATION							CROSS SWITCH PHASE (0-16)									
LOCK IN RED							NTCIP VOLUME									
LOCK IN YELLOW				NTCIP OCCUPANCY				PMT QUEUE DELAY								
<b>TYPE G GREEN EXTENSION/DELAY DETECTOR PARAMETER SETTINGS</b>																
EXTEND TIME (0-25.5 SEC.)							DELAY TIME (0-255.0 SEC.)									
USE ADDED INITIAL CALCULATION							CROSS SWITCH PHASE (0-16)									
LOCK IN RED							NTCIP VOLUME									
LOCK IN YELLOW				NTCIP OCCUPANCY				PMT QUEUE DELAY								
<b>TYPE N NTCIP DETECTOR PARAMETER SETTINGS</b>																
CALL OPTION (YES/NO)							DELAY TIME (0-255.0 SEC.)									
EXTENSION OPTION (PASSAGE)							EXTENSION TIME (0-25.5 SEC)									
EXTENSION OPTION (QUEUE)							QUEUE LIMIT (0-255 SEC.)									
USE ADDED INITIAL CALCULATION							CROSS SWITCH PHASE (0-16)									
LOCK IN RED							NTCIP VOLUME									
LOCK IN YELLOW				NTCIP OCCUPANCY				PMT QUEUE DELAY								
<b>TYPE B BIKE DETECTOR PARAMETER SETTINGS</b>																
EXTEND TIME (0-25.5 SEC.)							NTCIP VOLUME									
							NTCIP OCCUPANCY									

**Program Reference Card**

▪ Appendix D

*MM-6-2 Vehicle Detector Setup, sheet 11 of 16*

<b>General Detector Parameters — Note: Enter DET PH in MM-6-1.</b>																	
VEHICLE DETECTOR NUMBER (1-64)							VEHICLE DETECTOR PLAN NUMBER (1-4)										
DETECTOR TYPE (S, D, P, C, R, G, N, B)																	
ENABLE TS2 DETECTOR?											ENABLE ECPI LOG?						
PHASE NO.	1	2	3	4	5	6	7	8	9	10	11	12	13	14	15	16	

<b>Parameters Specific to the Detector Type — Note: There are no more parameters for type R (Red Extension).</b>																			
<b>TYPE S STANDARD DETECTOR PARAMETER SETTINGS</b>																			
EXTEND TIME (0-25.5 SEC.)							DELAY TIME (0-255.0 SEC.)												
USE ADDED INITIAL CALCULATION							CROSS SWITCH PHASE (0-16)												
LOCK IN RED							NTCIP VOLUME												
LOCK IN YELLOW							NTCIP OCCUPANCY							PMT QUEUE DELAY					
<b>TYPE D DISCONNECT QUEUE/STOP BAR DETECTOR PARAMETER SETTINGS</b>																			
DISCONNECT TIME (0-255 SEC.)																			
USE ADDED INITIAL CALCULATION							CROSS SWITCH PHASE (0-16)												
LOCK IN RED							NTCIP VOLUME												
LOCK IN YELLOW							NTCIP OCCUPANCY							PMT QUEUE DELAY					
<b>TYPE P PASSAGE QUEUE/STOP BAR DETECTOR PARAMETER SETTINGS</b>																			
PASSAGE EXTENSION TIME (0-255 SEC.)																			
USE ADDED INITIAL CALCULATION							CROSS SWITCH PHASE (0-16)												
LOCK IN RED							NTCIP VOLUME												
LOCK IN YELLOW							NTCIP OCCUPANCY							PMT QUEUE DELAY					
<b>TYPE C CALLING DETECTOR PARAMETER SETTINGS</b>																			
USE ADDED INITIAL CALCULATION							CROSS SWITCH PHASE (0-16)												
LOCK IN RED							NTCIP VOLUME												
LOCK IN YELLOW							NTCIP OCCUPANCY							PMT QUEUE DELAY					
<b>TYPE G GREEN EXTENSION/DELAY DETECTOR PARAMETER SETTINGS</b>																			
EXTEND TIME (0-25.5 SEC.)							DELAY TIME (0-255.0 SEC.)												
USE ADDED INITIAL CALCULATION							CROSS SWITCH PHASE (0-16)												
LOCK IN RED							NTCIP VOLUME												
LOCK IN YELLOW							NTCIP OCCUPANCY							PMT QUEUE DELAY					
<b>TYPE N NTCIP DETECTOR PARAMETER SETTINGS</b>																			
CALL OPTION (YES/NO)							DELAY TIME (0-255.0 SEC.)												
EXTENSION OPTION (PASSAGE)							EXTENSION TIME (0-25.5 SEC)												
EXTENSION OPTION (QUEUE)							QUEUE LIMIT (0-255 SEC.)												
USE ADDED INITIAL CALCULATION							CROSS SWITCH PHASE (0-16)												
LOCK IN RED							NTCIP VOLUME												
LOCK IN YELLOW							NTCIP OCCUPANCY							PMT QUEUE DELAY					
<b>TYPE B BIKE DETECTOR PARAMETER SETTINGS</b>																			
EXTEND TIME (0-25.5 SEC.)							NTCIP VOLUME												
							NTCIP OCCUPANCY												

MM-6-2 Vehicle Detector Setup, sheet 12 of 16

<b>General Detector Parameters — Note: Enter DET PH in MM-6-1.</b>																
VEHICLE DETECTOR NUMBER (1-64)							VEHICLE DETECTOR PLAN NUMBER (1-4)									
DETECTOR TYPE (S, D, P, C, R, G, N, B)																
ENABLE TS2 DETECTOR?							ENABLE ECPI LOG?									
PHASE NO.	1	2	3	4	5	6	7	8	9	10	11	12	13	14	15	16

<b>Parameters Specific to the Detector Type — Note: There are no more parameters for type R (Red Extension).</b>																
<b>TYPE S STANDARD DETECTOR PARAMETER SETTINGS</b>																
EXTEND TIME (0-25.5 SEC.)							DELAY TIME (0-255.0 SEC.)									
USE ADDED INITIAL CALCULATION							CROSS SWITCH PHASE (0-16)									
LOCK IN RED							NTCIP VOLUME									
LOCK IN YELLOW				NTCIP OCCUPANCY				PMT QUEUE DELAY								
<b>TYPE D DISCONNECT QUEUE/STOP BAR DETECTOR PARAMETER SETTINGS</b>																
DISCONNECT TIME (0-255 SEC.)																
USE ADDED INITIAL CALCULATION							CROSS SWITCH PHASE (0-16)									
LOCK IN RED							NTCIP VOLUME									
LOCK IN YELLOW				NTCIP OCCUPANCY				PMT QUEUE DELAY								
<b>TYPE P PASSAGE QUEUE/STOP BAR DETECTOR PARAMETER SETTINGS</b>																
PASSAGE EXTENSION TIME (0-255 SEC.)																
USE ADDED INITIAL CALCULATION							CROSS SWITCH PHASE (0-16)									
LOCK IN RED							NTCIP VOLUME									
LOCK IN YELLOW				NTCIP OCCUPANCY				PMT QUEUE DELAY								
<b>TYPE C CALLING DETECTOR PARAMETER SETTINGS</b>																
USE ADDED INITIAL CALCULATION							CROSS SWITCH PHASE (0-16)									
LOCK IN RED							NTCIP VOLUME									
LOCK IN YELLOW				NTCIP OCCUPANCY				PMT QUEUE DELAY								
<b>TYPE G GREEN EXTENSION/DELAY DETECTOR PARAMETER SETTINGS</b>																
EXTEND TIME (0-25.5 SEC.)							DELAY TIME (0-255.0 SEC.)									
USE ADDED INITIAL CALCULATION							CROSS SWITCH PHASE (0-16)									
LOCK IN RED							NTCIP VOLUME									
LOCK IN YELLOW				NTCIP OCCUPANCY				PMT QUEUE DELAY								
<b>TYPE N NTCIP DETECTOR PARAMETER SETTINGS</b>																
CALL OPTION (YES/NO)							DELAY TIME (0-255.0 SEC.)									
EXTENSION OPTION (PASSAGE)							EXTENSION TIME (0-25.5 SEC)									
EXTENSION OPTION (QUEUE)							QUEUE LIMIT (0-255 SEC.)									
USE ADDED INITIAL CALCULATION							CROSS SWITCH PHASE (0-16)									
LOCK IN RED							NTCIP VOLUME									
LOCK IN YELLOW				NTCIP OCCUPANCY				PMT QUEUE DELAY								
<b>TYPE B BIKE DETECTOR PARAMETER SETTINGS</b>																
EXTEND TIME (0-25.5 SEC.)							NTCIP VOLUME									
							NTCIP OCCUPANCY									

**Program Reference Card**

▪ Appendix D

**MM-6-2 Vehicle Detector Setup, sheet 13 of 16**

<b>General Detector Parameters — Note: Enter DET PH in MM-6-1.</b>																	
VEHICLE DETECTOR NUMBER (1-64)							VEHICLE DETECTOR PLAN NUMBER (1-4)										
DETECTOR TYPE (S, D, P, C, R, G, N, B)																	
ENABLE TS2 DETECTOR?											ENABLE ECPI LOG?						
PHASE NO.	1	2	3	4	5	6	7	8	9	10	11	12	13	14	15	16	

<b>Parameters Specific to the Detector Type — Note: There are no more parameters for type R (Red Extension).</b>																			
<b>TYPE S STANDARD DETECTOR PARAMETER SETTINGS</b>																			
EXTEND TIME (0-25.5 SEC.)							DELAY TIME (0-255.0 SEC.)												
USE ADDED INITIAL CALCULATION							CROSS SWITCH PHASE (0-16)												
LOCK IN RED							NTCIP VOLUME												
LOCK IN YELLOW							NTCIP OCCUPANCY							PMT QUEUE DELAY					
<b>TYPE D DISCONNECT QUEUE/STOP BAR DETECTOR PARAMETER SETTINGS</b>																			
DISCONNECT TIME (0-255 SEC.)																			
USE ADDED INITIAL CALCULATION							CROSS SWITCH PHASE (0-16)												
LOCK IN RED							NTCIP VOLUME												
LOCK IN YELLOW							NTCIP OCCUPANCY							PMT QUEUE DELAY					
<b>TYPE P PASSAGE QUEUE/STOP BAR DETECTOR PARAMETER SETTINGS</b>																			
PASSAGE EXTENSION TIME (0-255 SEC.)																			
USE ADDED INITIAL CALCULATION							CROSS SWITCH PHASE (0-16)												
LOCK IN RED							NTCIP VOLUME												
LOCK IN YELLOW							NTCIP OCCUPANCY							PMT QUEUE DELAY					
<b>TYPE C CALLING DETECTOR PARAMETER SETTINGS</b>																			
USE ADDED INITIAL CALCULATION							CROSS SWITCH PHASE (0-16)												
LOCK IN RED							NTCIP VOLUME												
LOCK IN YELLOW							NTCIP OCCUPANCY							PMT QUEUE DELAY					
<b>TYPE G GREEN EXTENSION/DELAY DETECTOR PARAMETER SETTINGS</b>																			
EXTEND TIME (0-25.5 SEC.)							DELAY TIME (0-255.0 SEC.)												
USE ADDED INITIAL CALCULATION							CROSS SWITCH PHASE (0-16)												
LOCK IN RED							NTCIP VOLUME												
LOCK IN YELLOW							NTCIP OCCUPANCY							PMT QUEUE DELAY					
<b>TYPE N NTCIP DETECTOR PARAMETER SETTINGS</b>																			
CALL OPTION (YES/NO)							DELAY TIME (0-255.0 SEC.)												
EXTENSION OPTION (PASSAGE)							EXTENSION TIME (0-25.5 SEC)												
EXTENSION OPTION (QUEUE)							QUEUE LIMIT (0-255 SEC.)												
USE ADDED INITIAL CALCULATION							CROSS SWITCH PHASE (0-16)												
LOCK IN RED							NTCIP VOLUME												
LOCK IN YELLOW							NTCIP OCCUPANCY							PMT QUEUE DELAY					
<b>TYPE B BIKE DETECTOR PARAMETER SETTINGS</b>																			
EXTEND TIME (0-25.5 SEC.)							NTCIP VOLUME												
							NTCIP OCCUPANCY												



MM-6-2 Vehicle Detector Setup, sheet 14 of 16

<b>General Detector Parameters — Note: Enter DET PH in MM-6-1.</b>																	
VEHICLE DETECTOR NUMBER (1-64)							VEHICLE DETECTOR PLAN NUMBER (1-4)										
DETECTOR TYPE (S, D, P, C, R, G, N, B)																	
ENABLE TS2 DETECTOR?							ENABLE ECPI LOG?										
PHASE NO.	1	2	3	4	5	6	7	8	9	10	11	12	13	14	15	16	

<b>Parameters Specific to the Detector Type — Note: There are no more parameters for type R (Red Extension).</b>																			
<b>TYPE S STANDARD DETECTOR PARAMETER SETTINGS</b>																			
EXTEND TIME (0-25.5 SEC.)							DELAY TIME (0-255.0 SEC.)												
USE ADDED INITIAL CALCULATION							CROSS SWITCH PHASE (0-16)												
LOCK IN RED							NTCIP VOLUME												
LOCK IN YELLOW							NTCIP OCCUPANCY							PMT QUEUE DELAY					
<b>TYPE D DISCONNECT QUEUE/STOP BAR DETECTOR PARAMETER SETTINGS</b>																			
DISCONNECT TIME (0-255 SEC.)																			
USE ADDED INITIAL CALCULATION							CROSS SWITCH PHASE (0-16)												
LOCK IN RED							NTCIP VOLUME												
LOCK IN YELLOW							NTCIP OCCUPANCY							PMT QUEUE DELAY					
<b>TYPE P PASSAGE QUEUE/STOP BAR DETECTOR PARAMETER SETTINGS</b>																			
PASSAGE EXTENSION TIME (0-255 SEC.)																			
USE ADDED INITIAL CALCULATION							CROSS SWITCH PHASE (0-16)												
LOCK IN RED							NTCIP VOLUME												
LOCK IN YELLOW							NTCIP OCCUPANCY							PMT QUEUE DELAY					
<b>TYPE C CALLING DETECTOR PARAMETER SETTINGS</b>																			
USE ADDED INITIAL CALCULATION							CROSS SWITCH PHASE (0-16)												
LOCK IN RED							NTCIP VOLUME												
LOCK IN YELLOW							NTCIP OCCUPANCY							PMT QUEUE DELAY					
<b>TYPE G GREEN EXTENSION/DELAY DETECTOR PARAMETER SETTINGS</b>																			
EXTEND TIME (0-25.5 SEC.)							DELAY TIME (0-255.0 SEC.)												
USE ADDED INITIAL CALCULATION							CROSS SWITCH PHASE (0-16)												
LOCK IN RED							NTCIP VOLUME												
LOCK IN YELLOW							NTCIP OCCUPANCY							PMT QUEUE DELAY					
<b>TYPE N NTCIP DETECTOR PARAMETER SETTINGS</b>																			
CALL OPTION (YES/NO)							DELAY TIME (0-255.0 SEC.)												
EXTENSION OPTION (PASSAGE)							EXTENSION TIME (0-25.5 SEC)												
EXTENSION OPTION (QUEUE)							QUEUE LIMIT (0-255 SEC.)												
USE ADDED INITIAL CALCULATION							CROSS SWITCH PHASE (0-16)												
LOCK IN RED							NTCIP VOLUME												
LOCK IN YELLOW							NTCIP OCCUPANCY							PMT QUEUE DELAY					
<b>TYPE B BIKE DETECTOR PARAMETER SETTINGS</b>																			
EXTEND TIME (0-25.5 SEC.)							NTCIP VOLUME												
							NTCIP OCCUPANCY												

**Program Reference Card**

▪ Appendix D

*MM-6-2 Vehicle Detector Setup, sheet 15 of 16*

<b>General Detector Parameters — Note: Enter DET PH in MM-6-1.</b>																	
VEHICLE DETECTOR NUMBER (1-64)							VEHICLE DETECTOR PLAN NUMBER (1-4)										
DETECTOR TYPE (S, D, P, C, R, G, N, B)																	
ENABLE TS2 DETECTOR?												ENABLE ECPI LOG?					
PHASE NO.	1	2	3	4	5	6	7	8	9	10	11	12	13	14	15	16	

<b>Parameters Specific to the Detector Type — Note: There are no more parameters for type R (Red Extension).</b>																			
<b>TYPE S STANDARD DETECTOR PARAMETER SETTINGS</b>																			
EXTEND TIME (0-25.5 SEC.)							DELAY TIME (0-255.0 SEC.)												
USE ADDED INITIAL CALCULATION							CROSS SWITCH PHASE (0-16)												
LOCK IN RED							NTCIP VOLUME												
LOCK IN YELLOW							NTCIP OCCUPANCY							PMT QUEUE DELAY					
<b>TYPE D DISCONNECT QUEUE/STOP BAR DETECTOR PARAMETER SETTINGS</b>																			
DISCONNECT TIME (0-255 SEC.)																			
USE ADDED INITIAL CALCULATION							CROSS SWITCH PHASE (0-16)												
LOCK IN RED							NTCIP VOLUME												
LOCK IN YELLOW							NTCIP OCCUPANCY							PMT QUEUE DELAY					
<b>TYPE P PASSAGE QUEUE/STOP BAR DETECTOR PARAMETER SETTINGS</b>																			
PASSAGE EXTENSION TIME (0-255 SEC.)																			
USE ADDED INITIAL CALCULATION							CROSS SWITCH PHASE (0-16)												
LOCK IN RED							NTCIP VOLUME												
LOCK IN YELLOW							NTCIP OCCUPANCY							PMT QUEUE DELAY					
<b>TYPE C CALLING DETECTOR PARAMETER SETTINGS</b>																			
USE ADDED INITIAL CALCULATION							CROSS SWITCH PHASE (0-16)												
LOCK IN RED							NTCIP VOLUME												
LOCK IN YELLOW							NTCIP OCCUPANCY							PMT QUEUE DELAY					
<b>TYPE G GREEN EXTENSION/DELAY DETECTOR PARAMETER SETTINGS</b>																			
EXTEND TIME (0-25.5 SEC.)							DELAY TIME (0-255.0 SEC.)												
USE ADDED INITIAL CALCULATION							CROSS SWITCH PHASE (0-16)												
LOCK IN RED							NTCIP VOLUME												
LOCK IN YELLOW							NTCIP OCCUPANCY							PMT QUEUE DELAY					
<b>TYPE N NTCIP DETECTOR PARAMETER SETTINGS</b>																			
CALL OPTION (YES/NO)							DELAY TIME (0-255.0 SEC.)												
EXTENSION OPTION (PASSAGE)							EXTENSION TIME (0-25.5 SEC)												
EXTENSION OPTION (QUEUE)							QUEUE LIMIT (0-255 SEC.)												
USE ADDED INITIAL CALCULATION							CROSS SWITCH PHASE (0-16)												
LOCK IN RED							NTCIP VOLUME												
LOCK IN YELLOW							NTCIP OCCUPANCY							PMT QUEUE DELAY					
<b>TYPE B BIKE DETECTOR PARAMETER SETTINGS</b>																			
EXTEND TIME (0-25.5 SEC.)							NTCIP VOLUME												
							NTCIP OCCUPANCY												

MM-6-2 Vehicle Detector Setup, sheet 16 of 16

<b>General Detector Parameters — Note: Enter DET PH in MM-6-1.</b>																
VEHICLE DETECTOR NUMBER (1-64)							VEHICLE DETECTOR PLAN NUMBER (1-4)									
DETECTOR TYPE (S, D, P, C, R, G, N, B)																
ENABLE TS2 DETECTOR?							ENABLE ECPI LOG?									
PHASE NO.	1	2	3	4	5	6	7	8	9	10	11	12	13	14	15	16

<b>Parameters Specific to the Detector Type — Note: There are no more parameters for type R (Red Extension).</b>																
<b>TYPE S STANDARD DETECTOR PARAMETER SETTINGS</b>																
EXTEND TIME (0-25.5 SEC.)							DELAY TIME (0-255.0 SEC.)									
USE ADDED INITIAL CALCULATION							CROSS SWITCH PHASE (0-16)									
LOCK IN RED							NTCIP VOLUME									
LOCK IN YELLOW				NTCIP OCCUPANCY				PMT QUEUE DELAY								
<b>TYPE D DISCONNECT QUEUE/STOP BAR DETECTOR PARAMETER SETTINGS</b>																
DISCONNECT TIME (0-255 SEC.)																
USE ADDED INITIAL CALCULATION							CROSS SWITCH PHASE (0-16)									
LOCK IN RED							NTCIP VOLUME									
LOCK IN YELLOW				NTCIP OCCUPANCY				PMT QUEUE DELAY								
<b>TYPE P PASSAGE QUEUE/STOP BAR DETECTOR PARAMETER SETTINGS</b>																
PASSAGE EXTENSION TIME (0-255 SEC.)																
USE ADDED INITIAL CALCULATION							CROSS SWITCH PHASE (0-16)									
LOCK IN RED							NTCIP VOLUME									
LOCK IN YELLOW				NTCIP OCCUPANCY				PMT QUEUE DELAY								
<b>TYPE C CALLING DETECTOR PARAMETER SETTINGS</b>																
USE ADDED INITIAL CALCULATION							CROSS SWITCH PHASE (0-16)									
LOCK IN RED							NTCIP VOLUME									
LOCK IN YELLOW				NTCIP OCCUPANCY				PMT QUEUE DELAY								
<b>TYPE G GREEN EXTENSION/DELAY DETECTOR PARAMETER SETTINGS</b>																
EXTEND TIME (0-25.5 SEC.)							DELAY TIME (0-255.0 SEC.)									
USE ADDED INITIAL CALCULATION							CROSS SWITCH PHASE (0-16)									
LOCK IN RED							NTCIP VOLUME									
LOCK IN YELLOW				NTCIP OCCUPANCY				PMT QUEUE DELAY								
<b>TYPE N NTCIP DETECTOR PARAMETER SETTINGS</b>																
CALL OPTION (YES/NO)							DELAY TIME (0-255.0 SEC.)									
EXTENSION OPTION (PASSAGE)							EXTENSION TIME (0-25.5 SEC)									
EXTENSION OPTION (QUEUE)							QUEUE LIMIT (0-255 SEC.)									
USE ADDED INITIAL CALCULATION							CROSS SWITCH PHASE (0-16)									
LOCK IN RED							NTCIP VOLUME									
LOCK IN YELLOW				NTCIP OCCUPANCY				PMT QUEUE DELAY								
<b>TYPE B BIKE DETECTOR PARAMETER SETTINGS</b>																
EXTEND TIME (0-25.5 SEC.)							NTCIP VOLUME									
							NTCIP OCCUPANCY									

MM-6-3 Ped Detector Phase Assignment

**NTCIP Mode**

PHASE	1	2	3	4	5	6	7	8
DETECTOR								
PHASE	9	10	11	12	13	14	15	16
DETECTOR								

**Econolite Mode**

PHASE	1	2	3	4	5	6	7	8	9	10	11	12	13	14	15	16
D E T E C T O R	1															
	2															
	3															
	4															
	5															
	6															
	7															
	8															
	9															
	10															
	11															
	12															
	13															
	14															
	15															
	16															

MM-6-4 Log Intervals – Speed Detector Setup

NTCIP LOG PERIOD	ECPI LOG PERIOD				LENGTH UNITS			
SPEED DET	1	2	3	4	5	6	7	8
LOCAL DET								
ONE/TWO DET								
VEH LENGTH								
TRAP LENGTH								
ENABLE LOG								
SPEED DET	9	10	11	12	13	14	15	16
LOCAL DET								
ONE/TWO DET								
VEH LENGTH								
TRAP LENGTH								
ENABLE LOG								

MM-6-5 Vehicle Detector Diagnostics, sheet 1 of 4

VEHICLE DIAGNOSTIC PLAN NUMBER 1													
DET	COUNTS PER MIN (ERRATIC)	NO ACTIVITY INTERVAL	MAX PRESENCE INTERVAL	MULTIPLIER	FAILED DET EXTEND TIME	FAILED DET DELAY TIME	DET	COUNTS PER MIN (ERRATIC)	NO ACTIVITY INTERVAL	MAX PRESENCE INTERVAL	MULTIPLIER	FAILED DET EXTEND TIME	FAILED DET DELAY TIME
1							33						
2							34						
3							35						
4							36						
5							37						
6							38						
7							39						
8							40						
9							41						
10							42						
11							43						
12							44						
13							45						
14							46						
15							47						
16							48						
17							49						
18							50						
19							51						
20							52						
21							53						
22							54						
23							55						
24							56						
25							57						
26							58						
27							59						
28							60						
29							61						
30							62						
31							63						
32							64						

MM-6-5 Vehicle Detector Diagnostics, sheet 2 of 4

VEHICLE DIAGNOSTIC PLAN NUMBER 2													
DET	COUNTS PER MIN (ERRATIC)	NO ACTIVITY INTERVAL	MAX PRESENCE INTERVAL	MULTIPLIER	FAILED DET EXTEND TIME	FAILED DET DELAY TIME	DET	COUNTS PER MIN (ERRATIC)	NO ACTIVITY INTERVAL	MAX PRESENCE INTERVAL	MULTIPLIER	FAILED DET EXTEND TIME	FAILED DET DELAY TIME
1							33						
2							34						
3							35						
4							36						
5							37						
6							38						
7							39						
8							40						
9							41						
10							42						
11							43						
12							44						
13							45						
14							46						
15							47						
16							48						
17							49						
18							50						
19							51						
20							52						
21							53						
22							54						
23							55						
24							56						
25							57						
26							58						
27							59						
28							60						
29							61						
30							62						
31							63						
32							64						

MM-6-5 Vehicle Detector Diagnostics, sheet 3 of 4

VEHICLE DIAGNOSTIC PLAN NUMBER 3													
DET	COUNTS PER MIN (ERRATIC)	NO ACTIVITY INTERVAL	MAX PRESENCE INTERVAL	MULTIPLIER	FAILED DET EXTEND TIME	FAILED DET DELAY TIME	DET	COUNTS PER MIN (ERRATIC)	NO ACTIVITY INTERVAL	MAX PRESENCE INTERVAL	MULTIPLIER	FAILED DET EXTEND TIME	FAILED DET DELAY TIME
1							33						
2							34						
3							35						
4							36						
5							37						
6							38						
7							39						
8							40						
9							41						
10							42						
11							43						
12							44						
13							45						
14							46						
15							47						
16							48						
17							49						
18							50						
19							51						
20							52						
21							53						
22							54						
23							55						
24							56						
25							57						
26							58						
27							59						
28							60						
29							61						
30							62						
31							63						
32							64						

MM-6-5 Vehicle Detector Diagnostics, sheet 4 of 4

VEHICLE DIAGNOSTIC PLAN NUMBER 4													
DET	COUNTS PER MIN (ERRATIC)	NO ACTIVITY INTERVAL	MAX PRESENCE INTERVAL	MULTIPLIER	FAILED DET EXTEND TIME	FAILED DET DELAY TIME	DET	COUNTS PER MIN (ERRATIC)	NO ACTIVITY INTERVAL	MAX PRESENCE INTERVAL	MULTIPLIER	FAILED DET EXTEND TIME	FAILED DET DELAY TIME
1							33						
2							34						
3							35						
4							36						
5							37						
6							38						
7							39						
8							40						
9							41						
10							42						
11							43						
12							44						
13							45						
14							46						
15							47						
16							48						
17							49						
18							50						
19							51						
20							52						
21							53						
22							54						
23							55						
24							56						
25							57						
26							58						
27							59						
28							60						
29							61						
30							62						
31							63						
32							64						



MM-6-6 Ped Detector Diagnostics

PED DETECTOR DIAG PLAN 1				
DET	COUNTS PER MIN (ERRATIC)	NO ACTIVITY INTERVAL	MAX PRESENCE INTERVAL	MULTIPLIER
1				
2				
3				
4				
5				
6				
7				
8				
9				
10				
11				
12				
13				
14				
15				
16				

PED DETECTOR DIAG PLAN 2				
DET	COUNTS PER MIN (ERRATIC)	NO ACTIVITY INTERVAL	MAX PRESENCE INTERVAL	MULTIPLIER
1				
2				
3				
4				
5				
6				
7				
8				
9				
10				
11				
12				
13				
14				
15				
16				

PED DETECTOR DIAG PLAN 3				
DET	COUNTS PER MIN (ERRATIC)	NO ACTIVITY INTERVAL	MAX PRESENCE INTERVAL	MULTIPLIER
1				
2				
3				
4				
5				
6				
7				
8				
9				
10				
11				
12				
13				
14				
15				
16				

PED DETECTOR DIAG PLAN 4				
DET	COUNTS PER MIN (ERRATIC)	NO ACTIVITY INTERVAL	MAX PRESENCE INTERVAL	MULTIPLIER
1				
2				
3				
4				
5				
6				
7				
8				
9				
10				
11				
12				
13				
14				
15				
16				

---

**For your notes:**



## Event Log Messages

Log Message	Description
3 CRITICAL RFES IN 24 HOURS	3 critical SDLC communication errors occurred in the last 24 hours.
3 CRITICAL RFES IN 24 HOURS CLEARED	3 critical SDLC communication errors cleared.
ACCESS GRANTED:USER #	User login from keyboard is successful and access is granted.
ALARM ACTIVE	An alarm event happens.
ALARM INACTIVE	An alarm event clears.
AUTOMATIC FLASH ACTIVE	Controller is in automatic flash.
AUTOMATIC FLASH INACTIVE	Controller exits from automatic flash.
BATTERY LOW	Battery voltage drops below normal level.
CABINET DOOR CLOSED	Cabinet door has just been closed.
CABINET DOOR OPEN	Cabinet door is open.
COLOR MISMATCH FAULT FLASH	Controller SDLC output colors and MMU intersection colors have not matched for over 800 ms.
COMPATIBILITY FAULT FLASH	The controller compatibility table does not match the MMU compatibility table.
CONFLICT FAULT FLASH	MMU detected Conflict calls. Two or more conflicting colors are ON for over 500 ms.
COORDINATOR ACTIVE	Controller is running in Coordination mode.
COORDINATOR DATA ERRORS (FREE)	Invalid settings are found in the commanded pattern data. Fall back to Free mode.
COORDINATOR FAILURE (FREE)	When a Coordinator Fault is in effect and a Cycle Fault occurs again within two cycles of the coordination retry. Fall back to Free mode.

## Event Log Messages

▪ Appendix E

Log Message	Description
COORDINATOR FAULT (FREE)	When a Cycle Fault is in effect and the serviceable call has been serviced within two cycles after the Cycle Fault. Fall back to Free mode.
COORDINATOR LOCAL FREE	Input commands the controller to go to FREE mode.
COORDINATOR PROGRAM FREE	TBC commands the controller to go to FREE mode.
CRC PROTECT FAIL - NEMA CRC CHECKING	CRC error was detected in the running database.
CYCLE FAILURE FLASH	Cycling diagnostics indicate that a serviceable call exists that has not been serviced for two cycles during Free.
CYCLE FAULT (FREE)	Cycling diagnostics indicate that a serviceable call exists that has not been serviced for two cycles during Coordination. Thus the controller will be in Free mode.
DATA CHANGE INITIATED (KEYBOARD)	Data change from keyboard detected since last data change timeout.
DATA CHANGE TIME OUT (KEYBOARD)	No data change from keyboard in the last 20 minutes.
DET BIU # RFE	Detector BIU communication error.
DET BIU # RFE CLEAR	Detector BIU communication error clears.
DET BIU DISABLED #	Record which detector BIU is disabled.
DET BIU ENABLED #	Record which detector BIU is enabled.
ECPIP DATABASE DOWNLOAD	New database has been downloaded to the controller through the ECPIP protocols.
EXIT ERROR FLASH	MMU flash error is cleared.
FLASH TEST	Flash Test has failed (ASC/3 NEMA only).
HRI CROSSING# TO PMT NOT SET	HRI messages are being received but all the crossing numbers are not associated with a preempt.
HRI PMT# IS NOT ENABLED	HRI messages are being received for a crossing but the preempt associated with the crossing is not enabled.
HRI PMT# IS NOT HIGH PRIORITY	Preempt is linked to an HRI crossing but is low priority. It needs to be high priority.
HRI RBHA FAULT FLASH	The HRI message is not receiving messages from the controller.
HRI RX FAULT FLASH	HRI messages are not being received by the controller.

Log Message	Description
HRI SO FAULT FLASH	HRI messages indicate that the railroad equipment is offline.
IDOT CRC FAULT FLASH	HRI CRC check has failed.
IDOT DATABASE CRC CHECKING FAILED	IDOT database CRC does not match with the preset value.
IDOT TRACK SWITCH FAIL	IDOT track switch fail input is active.
IM DATABASE DOWNLOAD	Intersection Monitor – new database has been downloaded to the controller.
IM PREEMPTOR MAX PRESENCE	Intersection Monitor – a preemption has been active longer than or equal to the programmed maximum presence time.
IM PREEMPTOR NO ACTIVITY	Intersection Monitor – no preemption is active in the programmed NO ACTIVITY time.
IM PREEMPTOR NORMAL	Intersection Monitor – a No Activity or Maximum Presence event clears.
IM REP CALL DIAG	Intersection Monitor – failed to connect the phone call.
IM TRACK SWITCH FAIL CLEAR	IDOT track switch fail input clears.
LOCAL FLASH ACTIVE	The CU has detected local flash going active.
LOCAL FLASH INACTIVE	The CU has detected local flash being removed.
MAX GREEN EVENT	Intersection Monitor – maximum green time on a phase is greater than or equal to the programmed maximum green time.
MAX GREEN EVENT CLEAR	Intersection Monitor – a maximum green event has been logged and the phase later terminates with a total accumulated green time less than the programmed maximum green time.
MMU DISABLED	MMU is disabled.
MMU ENABLED	MMU is enabled.
MMU FLASH: +24 VOLT MONITOR I	MMU is reporting that the 24 Volts I is not within limits and placed the intersection in Flash.
MMU FLASH: +24 VOLT MONITOR II	MMU is reporting that the 24 Volts II is not within limits and placed the intersection in Flash.
MMU FLASH: CONFLICT	MMU is reporting that is has detected a conflict between two channels and placed the intersection in Flash.

## Event Log Messages

▪ *Appendix E*

Log Message	Description
MMU FLASH: DIAGNOSTIC FAILURE	MMU is reporting that a diagnostic failure has occurred and placed the intersection in Flash.
MMU FLASH: MINIMUM CLEARANCE FAILURE	MMU is reporting that yellow color has not been on long enough and placed the intersection in Flash.
MMU FLASH: PORT I TIMEOUT FAILURE	MMU is not receiving valid communication from the controller and placed the intersection in Flash.
MMU FLASH: RED FAILURE	MMU is reporting that one or more channels have no colors present.
MMU FLASH: VOLTAGE MONITOR	MMU is reporting that the CVM is not active.
MMU RFE	MMU communication error.
MMU RFE CLEAR	MMU communication error clears.
MMU STATUS FLASH (HARDWARE INPUTS)	This is a second message added to the log to indicate that the MMU has found an error.
NETWORK DOWN: STARTUP MAC INCORRECT	Ethernet port fails to operate.
OFF LINE	The CU is not in normal operation (that is, in flash or preempt).
ON LINE	The CU is in normal operation.
PMT GATEDOWN FAULT FLASH	The CU has detected a gatedown fault and put the intersection into flash.
PMT INTERLOCK FAULT FLASH	The CU has detected a preempt interlock error and put the intersection into flash.
PORT 3B CANNOT BE SET TO TERMINAL	Port 3B is set incorrectly for terminal, possibly via IM command.
PORTS CANNOT BE SET TO SAME PROTOCOL	Same Protocol cannot be set on a different port, possibly via IM command.
POWER FAILURE DETECTED	Power interruption is detected.
POWER OFF	Power OFF Event.
POWER ON	Power ON Event.
POWER ON FLASH ACTIVE	The CU is powering up and keeping the intersection in flash.
POWER ON FLASH INACTIVE	The CU is coming out of power ON flash.
POWER RESTORE	Short power interruption happened and power is restored.

Log Message	Description
PREEMPTOR ACTIVE	The controller is operating in preemption mode.
PREEMPTOR INACTIVE	The preemption goes inactive.
RESPONSE FRAME FAULT FLASH	The CU has detected an RFE error and put the intersection into flash.
RF129 DUAL INDICATION FAULT FLASH	Enhanced MMU – one or more channels have multiple colors active. Refer to MM-7-7-3 for more information.
RF129 EXTERNAL WATCHDOG FAULT FLASH	Enhanced MMU – the external WDOG signal to the MMU has a failure.
RF129 FIELD CHECK FAULT FLASH	Enhanced MMU Message. Refer to MMU Manufacturer's manual for more information.
RF129 RP DETECTION STATUS	Enhanced MMU – one or more channels turning ON and OFF. For more details, go to MM-7-7-5.
RF129 SPARE #1	MMU bit setting. Refer to MMU Manufacturer's manual for more information.
RF129 SPARE #2	MMU bit setting. Refer to MMU Manufacturer's manual for more information.
RF129 SPARE #3	MMU bit setting. Refer to MMU Manufacturer's manual for more information.
RF129 SPARE #3 FLASH	Enhanced MMU message. Refer to MMU Manufacturer's manual for more information.
RF129 SPARE #4	MMU bit setting. Refer to MMU Manufacturer's manual for more information.
RF129 SPARE #5	MMU bit setting. Refer to MMU Manufacturer's manual for more information.
RF129 SPARE #6	MMU bit setting. Refer to MMU Manufacturer's manual for more information.
RF129 SPARE #6 FLASH	Enhanced MMU. Refer to MMU Manufacturer's manual for more information.
RF129 YELLOW PLUS RED CLEARANCE FLASH	Enhanced MMU – Short or Skipped Yellow.
RFE TEST	RFE 158 Test.
RFE TEST CLEAR	Clear RFE 158 Test.

## Event Log Messages

- Appendix E

Log Message	Description
STATIC RAM TEST	OS has failed a static RAM test (ASC/3 NEMA only).
TEST DISABLE	Disable RFE 158 Test.
TEST ENABLE	Enable RFE 158 Test.
TF # RFE	TF BIU # has RFE errors.
TF # RFE CLEAR	TF BIU # RFE errors have been cleared.
TF # DISABLED	TF BIU # has been disabled.
TF # ENABLED	TF BIU # has been enabled.
TSP CALL RECEIVED	A TSP call is detected.
TSP CYCLE ACTIVATED	A TSP call is being serviced. TSP timings, omits and recalls are in effect.
TSP CYCLE TERMINATED	TSP operation has been terminated.
TSP INHIBITED CALL RECEIVED	A TSP call is detected but cannot be serviced.
UPS POWER OFF	Intersection Monitor – Controller is running on UPS power.
UPS POWER ON	Intersection Monitor – Controller is no longer running on UPS power.
WSA ON BEFORE TRACK CLEARANCE	HRI – WSA occurred before the CU entered track clearance.
YELLOW PLUS RED CLEARANCE FLASH	Enhanced MMU – short or missing Yellow.



---

## ASC/3 Hardware Diagnostic Screens

The *ASC/3* Controller hardware diagnostics software is a part of the *ASC/3* Boot software package and appears as option 7 on the Boot Menu.

### To access the Hardware Diagnostic Menu:

- 1 While powering up the controller, simultaneously press **1** and **CLEAR**.

The Boot Menu screen comes into view:

```
MM/DD/YYYY      BOOT MENU      HH:MM:SS

1. DOWNLOAD FILES  6. SET WORKING DIR
2. UPLOAD OPTIONS  7. RUN H/W DIAGS
3. FILE SYSTEM     8. CLOCK/CALENDAR
4. SETUP NETWORK   9. SHOW BOOT CFG
5. SELECT APP      0. RESTART

PRESS KEYS 1..9, OR 0 TO SELECT
```

- 2 Press **7**.

The Hardware Diagnostic Menu (Screen HD, also shown below) comes into view.

```
HARDWARE DIAGNOSTIC MENU

1. DISPLAY          8. TELEMETRY I/O
2. KEYPAD           9. S-RAM
3. PORT1            0. ETHERNET
4. PORT2            A. RTC/OTHER
5. PORT3A           B. DATA MODULE
6. PORT3B           C. AUTO-LOOP
7. TS2 "ABCD" I/O  D. TS2 SUITCASE

PRESS
0..9 TO SELECT 0-9
SPEC FUNC 1-3 TO SELECT A-C
```



**HD-5**

```

PORT 3A TEST

TESTING HANDSHAKE SIGNALS [PASS]
PACKET TESTING PPPPPPPPPPPPPPP

No tx/rx failures!

*****
*TEST PASSED*
*****

PRESS ANY KEY TO RETURN
    
```

**HD-6**

```

TELEMETRY INTERFACE LOOPBACK

TESTING CTRL SIGS [PASS]
TESTING HANDSHAKE SIGNALS [PASS]

PACKET TESTING P3B PPPPPPPPPPPPPPP
No tx/rx failures!

PACKET TESTING P3C PPPPPPPPPPPPPPP
No tx/rx failures!

*****
*TEST PASSED*
*****

PRESS ANY KEY TO RETURN
    
```

**HD-7**

```

TS2 TYPE 2 LOOPBACK

Testing output 118
Input 94 has failed with Output 118

3827 3830 3831 3832 391f 3a2b 3b25 3c33
3d41 3e42 3f44 4034 4133 4234 433a 443d
4446 4539 4638 4735 4843 4934 4a3d 4a46
4b40 4c3f 4d45 4e47 4f3c 5036 5133 5242
533e 543e 5537 5636 5735 5845 5938 5a44
5b65 5c62 5d61 5d67 5e68 5f63 6064 6166
624c 635d 64 ***** 4d 684b 694a
6a60 6b55 6c *TEST FAILED* 54 7053 7152
7256 7358 74 ***** 5a 765c 765e
2c2c 2c2e 2d1c 2e21 2f1e 2f2d 3048 313b

PRESS ANY KEY TO RETURN
    
```

**HD-8**

```

TELEMETRY I/O LOOPBACK

*****
*NO HARDWARE*
*****

PRESS ANY KEY TO RETURN
    
```

**HD-9**

```

S-RAM TEST

CURRENTLY TESTING LOCATION 207FFF0

512kb MEMORY TESTS GOOD

*****
*TEST PASSED*
*****

PRESS ANY KEY TO RETURN
    
```

**HD-0**

```

ETHERNET TEST

PINGING 90.0.0.1 [PASSED]

*****
*TEST PASSED*
*****

PRESS ANY KEY TO RETURN
    
```

▪ Appendix F

**HD-A**

```
RTC/OTHER TESTS

GETTING TIME      [PASSED]
GETTING TIME      [PASSED]
CLOCK IS RUNNING  [PASSED]
TESTING LINE FREQ. [PASSED]
TESTING CVM/FM SIGS. [PASSED]

*****
*TEST PASSED*
*****

PRESS ANY KEY TO RETURN
```

**HD-B**

```
DATA MODULE TEST

FORMAT COMPLETE

CHECKING ERASURE  [PASSED]

READING FLASH BLOCK [PASSED]

*****
*TEST PASSED*
*****

PRESS ANY KEY TO RETURN
```

**HD-C**

```
AUTOMATICALLY PERFORMS
ENTIRE SEQUENCE OF 14
DIAGNOSTIC TESTS AND
THEN DISPLAYS STATS
OF THE RESULTS BEFORE
REPEATING THE FULL
SEQUENCE.
```

**HD-D**

```
TS1 SUITCASE TEST

Inputs
0123.....
4567.....
89AB.....
C .....

Outputs
0123.....
4567.....
89AB.....
CDE .....
01234567 01234567 01234567 01234567

PRESS ANY KEY TO RETURN
```



# Part Number and Software File Management

## ASC/3, ASC/3-2070 and ASC/3-LX Part Numbers

ASC/3 Traffic software technology is common for both ASC/3 NEMA HW and 2070 HW. Because of SW similarity, part numbers listed below for Controller software running on these 2 HW platforms are, therefore, similar.

Control Part #	Description	Note
<b>ASC/3 NEMA Related Parts</b>		
100-1082-2xx	ASC/3 SW, where xx is the ECO SW version number of the form 2.xx.yy.	
100-1082-5xx	ASC/3 SW CD, where xx is the ECO SW version number of the form 2.xx.yy.	
100-1047-2xx	ASC/3 OS SW version 1.xx.yy, 60 Hz version	USA
100-1105-2xx	ASC/3 OS SW version 2.xx.yy, 50 Hz version	International
100-1095-501	ASC/3 Data Key for TSP	
100-1095-502	ASC/3 Data Key for ASC/3 IM	
100-1095-503	ASC/3 Data Key for ASC/3 TSP/IM	
<b>ASC/3-2070 Related Parts</b>		
117-1082-2xx	ASC/3-2070 SW, where xx is the ECO SW version number of the form 22.xx.yy.	
117-1082-5xx	ASC/3-2070 SW CD, where xx is the ECO SW version number of the form 22.xx.yy.	
117-1052-001	ASC/3-2070 Keyboard Overlay	
117-1053-2xx	2002 OS Image for 2002 version of 2070 HW. Required for ASC/3 2070 SW support on 2002 HW.	
xx = The version number (to order the latest version, use xx in the part number)		
yy = Possible maintenance number		

▪ Appendix G

Control Part #	Description	Note
117-1054-2xx	1999 OS Image for 2002 version of 2070 HW. Required for <i>ASC/3-2070</i> SW support on 2002 HW.	
117-1096-501	<i>ASC/3-2070</i> Token Key TSP	
<b>ASC/3-LX Related Parts</b>		
117-1052-001	<i>ASC/3-2070</i> (also for <i>ASC/3-LX</i> ) Keyboard Overlay	
117-1096-501	<i>ASC/3-2070</i> (also for <i>ASC/3-LX</i> ) Token Key TSP	
119-1046-2xx	Software, U-Boot, Linux, LX/2070 Engine Board	
119-1047-2xx	Software, Linux Package, LX/2070 Engine Board	
119-1048-2xx	Software, LPC-1754 Micro Controller, LX/2070 Engine Board	
119-1049-2xx	Software, LPC 1343 Micro Controller, 2070 Host Board	
119-1051-2xx	Software, <i>ASC/3-LX/2070</i> Traffic Application where xx is the ECO SW version number of the form 32.xx.yy	
<b>Documents and Utilities</b>		
100-0903-001	Programming Manual for <i>ASC/3</i> , <i>ASC/3-2070</i> and <i>ASC/3-LX</i>	
100-0904-001	<i>ASC/3</i> Maintenance Manual	
100-0903-003	TSP Manual	
100-0903-004	<i>ASC/3</i> Configurator Manual	
100-0903-005	Intersection Monitor Quick Start Guide — only for <i>ASC/3</i>	
100-0903-007	<i>ASC/3</i> Program Reference Card	
100-0903-008	<i>ASC/3</i> IEEE 1570 User Guide	
100-1104-001	<i>ASC/3</i> Configurator	
100-1081-001	<i>ASC/3</i> Security File Manager	
xx = The version number (to order the latest version, use xx in the part number) yy = Possible maintenance number		

## Database Sets

### ASC/3 and ASC/3-2070 Database Set

Both *ASC/3* on NEMA HW and *ASC/3-2070* on 2070 HW are designed in accordance with *ASC/3* Database requirements. The *ASC/3* Database consists of a set of files. The Database set is created by authorized personnel using various SW tools and can be downloaded via the method and protocol associated with those SW tools. This document goes over major aspects of the Database Set Creation, Modification and Management.

*ASC/3* Database is a set of files that are user-configurable and is loaded to the controller through various methods. Below are the listing and the descriptions of the Database files.

Filename on PC	Filename on Controller	Description
For <i>ASC/3</i> : <sup>1</sup> Nxxxx .db  For <i>ASC/3-C1/C11</i> and TS2 Type 1 version of the rackmount: <sup>1</sup> Rxxxx .db  For <i>ASC/3-2070</i> 2A module: <sup>1</sup> Axxxx .db  For <i>ASC/3-2070</i> 2B and 2N modules: <sup>1</sup> Bxxxx .db  AnyName .db can be used. Conversion takes place during download.	ASC3 .DB           Nxxxx .DB Rxxxx .DB  <b>Or</b> Axxxx .DB  <b>Or</b> Bxxxx .DB	Copied to the controller as ASC3.DB, becoming the current DB. This is the active primary Database for the controller. It contains timing, configuration, and I/O mapping information.  Copied to the controller with the same filename. If file on the controller has this name, it is treated as the default Database. If there are multiple default databases of the same type, the highest number default database is selected.
ASC3 .DT	ASC3 .DT	Secondary database that contains optional feature or extended feature such as TSP, IM.
USERCFG .DB	USERCFG .DB	Security file that is used to determine who has access or not. Not needed if no access control is required.
ASC3 .EXT	ASC3 .EXT	Extended Logic Processor file that is used by <i>ASC/3</i> to manage groups of Logic Processor Statements. Not needed if no Logic Processor Statement is required above Statement 100.
<sup>1</sup> xxxx is a four-digit number from 3001 to 9999, formally assigned and managed by Cabinet Engineering to designate a customer. 3000 is reserved for the default engineering database configuration.		

### ASC/3-LX Database Set

An 2070 running ASC/3-LX software on a Linux module runs on a single configuration file. The database set is created by authorized personnel using various SW tools and can be downloaded via the method and protocol associated with those SW tools. This document goes over major aspects of the Database Set Creation, Modification and Management.

The database is a set of files that are user-configurable and is loaded to the controller through various methods. Below are the listing and the descriptions of the database files.

Filename on PC	Filename on Controller	Description
ASC3 . CFG	ASC3 . CFG	<p>This is the active database for the controller. It contains timing, configuration, I/O, access control and groups of logic processor statements.</p> <p><b>Note</b> • In the ASC/3 and ASC/3-2070, this data is stored separately in ASC3.DB, ASC3.DT, USERCFG.DB and ASC3.EXT.</p>
Lxxxx <sup>1</sup> . CFG	Lxxxx . CFG	<p>Copied to the controller with the same filename. If the file on the controller has this name, it is treated as the default Database. If there are multiple default databases of the same type, the highest number default database is selected.</p> <p>L3000.CFG is the default database for the 2070-1C CPU module. However, it does not contain any I/O mapping information. When the file is loaded in the controller:</p> <ol style="list-style-type: none"> <li><b>1</b> The I/O mapping is set to the default I/O mapping of the running FIO (for example, 2A).</li> <li><b>2</b> The I/O mapping is saved in ASC3.CFG, which configures it for this FIO.</li> <li><b>3</b> When the FIO is changed, at power up, the controller goes into flash and shows a message that asks if you want to change the I/O mapping to the default I/O mapping of the new FIO.</li> <li><b>4</b> The changes are enabled on the next power up.</li> </ol>

1

xxxx is a four-digit number from 3001 to 9999, formally assigned and managed by Cabinet Engineering to designate a customer.



## Features Unique to the ASC/3-LX Releases First Introduced in Ver. 32.58.00

- Single Configuration file for all controller and cabinet types. This file replaces ASC3.DB, ASC3.DT, ASC3.EXT and USERCFG.DB
  - Default Econolite configuration file is L3000.CFG
  - Active DB is ASC3.CFG
  - Default DB is Lxxxx .CFG
- You can move the Configuration file from one controller type to another controller type. The I/O mapping resets to adapt to the new controller.
- You can use the USB port to:
  - Print a Log (MM-8-6-2)
  - Print the Configuration (MM-8-3)
  - Upgrade the software
  - Upgrade the configuration
  - Upload the configuration

## Single USB Update for 2070-1C Application Software

- A script has been created that can update an ATC NEMA controller using one USB drive. It is capable of updating at the same time all 4 of the previous individual USB drive contents. The One Disk script processes the files from the 4 disk USB zip set. There are 4 groups, one from each of the 4 original zip files:
  - Disk 1: OSPackage-<version>.zip for the Engine Board OS
  - Disk 2: microcontroller.zip for the various microcontrollers
  - Disk 3: AGC OS
  - Disk 4: asc3app and cobalt zip files

## Creating and Restoring Default Database

Upon the acceptance of the programmed database, we advise you to set it as the default database using the MM-8-1 Copy feature: **Controller Data > Default Database**. Restoring to the Default Database (MM-8-1 Copy feature: **DEFAULT DATABASE > CONTROLLER DATA**) will not operate if you do not create the Default Database.

## Database Creation and Modification

There are several ways to upgrade *ASC/3*, *ASC/3-2070* or *ASC/3-LX* software. The easiest way to upgrade SW is to use the Single Click software Installation Utility that comes with every software release package. Instruction for the Utility is also included.

**IMPORTANT** • Database upgrade is a destructive operation that may potentially change the Input and Output mapping of the Controller. Incorrect Input and Output mapping brings the intersection to flash. You must make sure that the upgraded Database has the same or desirable mapping for that controller.

**Note** • You can upgrade the *ASC/3-LX* software through the USB port in the 2070-1C CPU module.

### Supporting Software

There are other tools to create, manage, download (to the controller) and upload (from the controller) the *ASC/3* database. These tools are capable of Database Management:

Software	Description	Communication Method
<i>ASC/3</i> Configurator	Standalone software that can create and modify ASC3.DB and ASC3.DT	Via <i>ASC/3</i> SW Installers
<i>ASC/3</i> SW Installer	Standalone software that can download Application SW, Database, OS, and raw files to <i>ASC/3</i> NEMA Controller HW. It can upload a Database Set and logs. All database files must be in a single folder with no more than 1 type per file.	Serial Z-modem or Ethernet FTP
<i>ASC/3-2070</i> SW Installer	Standalone software that can install Application SW, Database, OS, and raw files to 2070 controller HW. It can upload Database Set and, in the future, logs. All database files must be in a single folder, with no more than 1 type per file.	Serial Z-modem or Ethernet FTP
<i>ASC/3-LX</i> SW Installer	Standalone software that can install Application SW, Database, OS, and raw files to 2070 controller HW. It can upload Database Set and, in the future, logs. All database files must be in a single folder, with no more than 1 type per file.	Serial Z-modem or Ethernet FTP
<i>ASC/3</i> File Security Manager Utility	Create and Manage <i>ASC/3</i> front panel security access. Security file generated from this utility can be downloaded, via the SW Installer, to allow security to take effect.	Via <i>ASC/3</i> SW Installers

<b>Software</b>	<b>Description</b>	<b>Communication Method</b>
<i>icons</i> or <i>Centracs</i>	Econolite Central SW	NTCIP over Serial or Ethernet
<i>ACS Lite</i>	FHWA funded Adaptive Control Software	NTCIP over Serial or Ethernet
<i>Centracs</i> Local Edition (LE)	Econolite standalone <i>Centracs</i> LE. The special version also provides the ability to import and export Logic Processor Statements from one database to another database.	NTCIP over Serial or Ethernet
<i>Aries</i>	Econolite Central SW over ECP/IP	Serial via ASC/2M
<i>Aries</i> Direct Connect	Econolite standalone <i>Centracs</i> LE over NTCIP	NTCIP over Serial or Ethernet

---

**For your notes:**

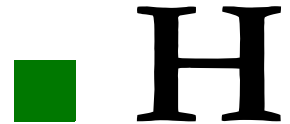

## Coordination Pattern

### *Selected by TS2 inputs*

Pattern	TS2 Plan - Offset	Pattern	TS2 Plan - Offset	Pattern	TS2 Plan - Offset
1	0-1	41	13-2	81	-
2	0-2	42	13-3	82	-
3	0-3	43	14-1	83	-
4	1-1	44	14-2	84	-
5	1-2	45	14-3	85	-
6	1-3	46	15-1	86	-
7	2-1	47	15-2	87	-
8	2-2	48	15-3	88	-
9	2-3	49	-	89	-
10	3-1	50	-	90	-
11	3-2	51	-	91	-
12	3-3	52	-	92	-
13	4-1	53	-	93	-
14	4-2	54	-	94	-
15	4-3	55	-	95	-
16	5-1	56	-	96	-
17	5-2	57	-	97	-
18	5-3	58	-	98	-
19	6-1	59	-	99	-
20	6-2	60	-	100	-
21	6-3	61	-	101	-
22	7-1	62	-	102	-
23	7-2	63	-	103	-
24	7-3	64	-	104	-
25	8-1	65	-	105	-
26	8-2	66	-	106	-
27	8-3	67	-	107	-
28	9-1	68	-	108	-
29	9-2	69	-	109	-
30	9-3	70	-	110	-
31	10-1	71	-	111	-
32	10-2	72	-	112	-
33	10-3	73	-	113	-
34	11-1	74	-	114	-
35	11-2	75	-	115	-
36	11-3	76	-	116	-
37	12-1	77	-	117	-
38	12-2	78	-	118	-
39	12-3	79	-	119	-
40	13-1	80	-	120	-

---

***For your notes:***

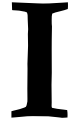

# ASC/3 Boot Menu Tree

To enter the Boot Menu, while powering up the controller

- ▶ Simultaneously press **1** and **CLEAR**.

MM ASC/3 BOOT MENU	MM-4-5 SET CONSOLE (PORT 3A) BAUD RATE
MM-1 DOWNLOAD FILES	MM-4-5-1 9600
MM-1-1 DOWNLOAD CONTROLLER IMAGE/SCREENS	MM-4-5-2 19200
MM-1-1-1 DOWNLOAD USING FTP	MM-4-5-3 38400
MM-1-1-2 DOWNLOAD USING ZMODEM	MM-4-5-4 57600
MM-1-2 DOWNLOAD SCREEN FILES ONLY	MM-4-5-5 115200
MM-1-2-1 DOWNLOAD USING FTP	MM-5 SELECT APP
MM-1-2-2 DOWNLOAD USING ZMODEM	MM-5-1 asc3App
MM-1-3 DOWNLOAD OPERATING SYSTEM IMAGE	MM-6 SET WORKING DIR
MM-1-3-1 DOWNLOAD USING FTP	MM-6-1 set1
MM-1-3-2 DOWNLOAD USING ZMODEM	MM-6-2 set2
MM-1-4 DOWNLOAD AUX. APPLICATION	MM-7 RUN H/W DIAGS
MM-1-4-1 DOWNLOAD USING FTP	MM-7-1 DISPLAY
MM-1-4-2 DOWNLOAD USING ZMODEM	MM-7-2 KEYPAD
MM-2 UPLOAD OPTIONS	MM-7-3 PORT1
MM-2-1 UPLOAD CONTROLLER FILES	MM-7-4 PORT2
MM-2-2 UPLOAD DATABASE	MM-7-5 PORT3A
This is also in the main controller.	MM-7-6 PORT3B
MM-3 FILE SYSTEM	MM-7-7 TS2 "ABCD" I/O
MM-3-1 FORMAT FILE SYSTEM	MM-7-8 TELEMETRY I/O
MM-3-2 REPAIR FILE SYSTEM	MM-7-9 S-RAM
MM-3-3 SHOW FILE LIST	MM-7-0 ETHERNET
MM-4 SETUP NETWORK	MM-7-A RTC/OTHER
MM-4-1 SET LOCAL IP ADDRESS	MM-7-B DATA MODULE
MM-4-2 SET LOCAL IP MASK	MM-7-C AUTO-LOOP
MM-4-3 SET FTP SERVER/HOST ADDRESS	MM-8 CLOCK/CALENDAR
MM-4-4 VIEW ETHERNET MAC ADDRESS	MM-9 SHOW BOOT CONFIG
	MM-0 RESTART

---

***For your notes:***



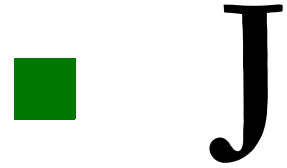

# Interface Connector Pin Lists

## Default Mapping for ASC/3 and ASC/3-2070

Connector A			Connector B			Connector C		
55-Pin (Plug) Type #22-55P			55-Pin (Socket) Type #22-55S			61-Pin (Socket) Type #24-61S		
<u>PIN</u>	<u>FUNCTION</u>	<u>I/O</u>	<u>PIN</u>	<u>FUNCTION</u>	<u>I/O</u>	<u>PIN</u>	<u>FUNCTION</u>	<u>I/O</u>
A	Fault Monitor	[O]	A	φ1 Phase Next	[O]	A	Status Bit A (Ring 2)	[O]
B	+24 VDC External	[O]	B	Preempt 2 Detector	[I]	B	Status Bit B (Ring 2)	[O]
C	Voltage Monitor	[O]	C	φ2 Phase Next	[O]	C	φ8 Dont Walk	[O]
D	φ1 Red	[O]	D	φ3 Green	[O]	D	φ8 Red	[O]
E	φ1 Dont Walk	[O]	E	φ3 Yellow	[O]	E	φ7 Yellow	[O]
F	φ2 Red	[O]	F	φ3 Red	[O]	F	φ7 Red	[O]
G	φ2 Dont Walk	[O]	G	φ4 Red	[O]	G	φ6 Red	[O]
H	φ2 Ped Clear	[O]	H	φ4 Ped Clear	[O]	H	φ5 Red	[O]
J	φ2 Walk	[O]	J	φ4 Dont Walk	[O]	J	φ5 Yellow	[O]
K	Vehicle Detector 2	[I]	K	φ4 Check	[O]	K	φ5 Ped Clear	[O]
L	Ped Detector 2	[I]	L	Vehicle Detector 4	[I]	L	φ5 Dont Walk	[O]
M	φ2 Hold	[I]	M	Ped Detector 4	[I]	M	φ5 Phase Next	[O]
N	Stop Time (Ring 1)	[I]	N	Vehicle Detector 3	[I]	N	φ5 Phase On	[O]
P	Inhibit MaxTerm(Ring1)	[I]	P	Ped Detector 3	[I]	P	Vehicle Detector 5	[I]
R	External Start	[I]	R	φ3 Phase Omit	[I]	R	Ped Detector 5	[I]
S	Interval Advance	[I]	S	φ2 Phase Omit	[I]	S	Vehicle Detector 6	[I]
T	Indicator Lamp Control	[I]	T	φ5 Ped Omit	[I]	T	Ped Detector 6	[I]
U	AC-Common	[I]	U	φ1 Phase Omit	[I]	U	Ped Detector 7	[I]
V	Chassis Ground	[I]	V	Ped Recycle(Ring 2)	[I]	V	Vehicle Detector 7	[I]
W	Logic Ground	[O]	W	Preempt 4 Detector	[I]	W	Ped Detector 8	[I]
X	Flashing Logic Out	[O]	X	Preempt 5 Detector	[I]	X	φ8 Hold Off	[I]
Y	Status Bit C (Ring1)	[O]	Y	φ3 Walk	[O]	Y	Force-Off (Ring 2)	[I]
Z	φ1 Yellow	[O]	Z	φ3 Ped Clear	[O]	Z	Stop Time (Ring 2)	[I]
a	φ1 Ped Clear	[O]	a	φ3 Dont Walk	[O]	a	Inhibit Max Term (Ring 2)	[I]
b	φ2 Yellow	[O]	b	φ4 Green	[O]	b	Test C	[I]
c	φ2 Green	[O]	c	φ4 Yellow	[O]	c	Status Bit C (Ring 2)	[O]
d	φ2 Check	[O]	d	φ4 Walk	[O]	d	φ8 Walk	[O]
e	φ2 Phase On	[O]	e	φ4 Phase On	[O]	e	φ8 Yellow	[O]
f	Vehicle Detector 1	[I]	f	φ4 Phase Next	[O]	f	φ7 Green	[O]
g	Ped Detector 1	[I]	g	φ4 Phase Omit	[I]	g	φ6 Green	[O]
h	φ1 Hold	[I]	h	φ4 Hold	[I]	h	φ6 Yellow	[O]
i	Force-Off (Ring 1)	[I]	i	φ3 Hold	[I]	i	φ5 Green	[O]
j	Ext Min Recall	[I]	j	φ3 Ped Omit	[I]	j	φ5 Walk	[O]
k	Manual Control Enable	[I]	k	φ6 Ped Omit	[I]	k	φ5 Check	[O]
m	Call To Non Actuate I	[I]	m	φ7 Ped Omit	[I]	m	φ5 Hold	[I]
n	Test A	[I]	n	φ8 Ped Omit	[I]	n	φ5 Phase Omit	[I]
p	AC+ (Control)	[I]	p	Overlap A Yellow	[O]	p	φ6 Hold	[I]

▪ Appendix J

Connector A		Connector B		Connector C	
55-Pin (Plug) Type #22-55P		55-Pin (Socket) Type #22-55S		61-Pin (Socket) Type #24-61S	
<u>PIN</u>	<u>FUNCTION</u>	<u>PIN</u>	<u>FUNCTION</u>	<u>PIN</u>	<u>FUNCTION</u>
q	I/O Mode Bit A	q	Overlap A Red	q	φ6 Phase Omit
r	Status Bit B (Ring 1)	r	φ3 Check	r	φ7 Phase Omit
s	φ1 Green	s	φ3 Phase On	s	φ8 Phase Omit
t	φ1 Walk	t	φ3 Phase Next	t	Vehicle Detector 8
u	φ1 Check	u	Overlap D Red	u	Red Rest Mode (Ring 2)
v	φ2 Ped Omit	v	Preempt 6 Detector	v	Omit Red Clear (Ring 2)
w	Omit AllRed Clr(Ring1)	w	Overlap D Green	w	φ8 Ped Clear
x	Red Rest (Ring 1)	x	φ4 Ped Omit	x	φ8 Green
y	I/O Mode Bit B	y	Free (No Coord)	y	φ7 Dont Walk
z	Call To Non Act II	z	MaxII Select(Ring 2)	z	φ6 Dont Walk
AA	Test B	AA	Overlap A Green	AA	φ6 Ped Clear
BB	Walk Rest Modifier	BB	Overlap B Yellow	BB	φ6 Check
CC	Status Bit A (Ring 1)	CC	Overlap B Red	CC	φ6 Phase On
DD	φ1 Phase On	DD	Overlap C Red	DD	φ6 Phase Next
EE	φ1 Ped Omit	EE	Overlap D Yellow	EE	φ7 Hold
FF	Ped Recycle (Ring 1)	FF	Overlap C Green	FF	φ8 Check
GG	Max II Select(Ring 1)	GG	Overlap B Green	GG	φ8 Phase On
HH	I/O Mode Bit C	HH	Overlap C Yellow	HH	φ8 Phase Next
				JJ	φ7 Walk
				KK	φ7 Ped Clear
				LL	φ6 Walk
				MM	φ7 Check
				NN	φ7 Phase On
				PP	φ7 Phase Next

## Default Mapping for ASC/3-LX

**Note** • The ASC/3-LX database is used in a 2070 controller with a 2070-1C CPU Module.

This default mapping is configured when an ASC/3-LX database (Ver. 32.59.00 and later) is loaded as a new database or if an existing database is deleted and then the ASC/3-LX database is loaded as a new database. Otherwise, the default mapping is as given in the previous table. The pins that are mapped differently—some pins mapped to channels (load switches) instead of phases—compared to the mapping in the previous table are in **bold type**. For a TS1 type cabinet, this gives you the ability use MM-1-3 to change the load switch outputs.

**Note** • This ASC/3-LX mapping does not operate in a 332 type cabinet.

In this table, LS = Load Switch

Connector A		Connector B		Connector C				
55-Pin (Plug) Type #22-55P		55-Pin (Socket) Type #22-55S		61-Pin (Socket) Type #24-61S				
<u>PIN FUNCTION</u>	<u>I/O</u>	<u>PIN FUNCTION</u>	<u>I/O</u>	<u>PIN FUNCTION</u>	<u>I/O</u>			
A	Fault Monitor	[O]	A	φ1 Phase Next	[O]	A	Status Bit A (Ring 2)	[O]
B	+24 VDC External	[O]	B	Preempt 2 Detector	[I]	B	Status Bit B (Ring 2)	[O]
C	Voltage Monitor	[O]	C	φ2 Phase Next	[O]	C	<b>LS 12 Red Dont Walk</b>	[O]
D	<b>LS 1 Red Dont Walk</b>	[O]	D	<b>LS 3 Green Walk</b>	[O]	D	<b>LS 8 Red Dont Walk</b>	[O]
E	φ1 Dont Walk	[O]	E	<b>LS 3 Yell Ped Clear</b>	[O]	E	<b>LS 7 Yellow Ped Clear</b>	[O]
F	<b>LS 2 Red Dont Walk</b>	[O]	F	<b>LS 3 Red Dont Walk</b>	[O]	F	<b>LS 7 Red Dont Walk</b>	[O]
G	<b>LS 9 Red Dont Walk</b>	[O]	G	<b>LS 4 Red Dont Walk</b>	[O]	G	<b>LS 6 Red Dont Walk</b>	[O]
H	<b>LS 9 Yellow Ped Clear</b>	[O]	H	<b>LS 10 Yell Ped Clear</b>	[O]	H	<b>LS 5 Red Dont Walk</b>	[O]
J	<b>LS 9 Green Walk</b>	[O]	J	<b>LS 10 Red Dont Walk</b>	[O]	J	<b>LS 5 Yellow Ped Clear</b>	[O]
K	Vehicle Detector 2	[I]	K	φ4 Check	[O]	K	φ5 Ped Clear	[O]
L	Ped Detector 2	[I]	L	Vehicle Detector 4	[I]	L	φ5 Dont Walk	[O]
M	φ2 Hold	[I]	M	Ped Detector 4	[I]	M	φ5 Phase Next	[O]
N	Stop Time (Ring 1)	[I]	N	Vehicle Detector 3	[I]	N	φ5 Phase On	[O]
P	Inhibit MaxTerm(Ring1)	[I]	P	Ped Detector 3	[I]	P	Vehicle Detector 5	[I]
R	External Start	[I]	R	φ3 Phase Omit	[I]	R	Ped Detector 5	[I]
S	Interval Advance	[I]	S	φ2 Phase Omit	[I]	S	Vehicle Detector 6	[I]
T	Indicator Lamp Control	[I]	T	φ5 Ped Omit	[I]	T	Ped Detector 6	[I]
U	AC-Common	[I]	U	φ1 Phase Omit	[I]	U	Ped Detector 7	[I]
V	Chassis Ground	[I]	V	Ped Recycle(Ring 2)	[I]	V	Vehicle Detector 7	[I]
W	Logic Ground	[O]	W	Preempt 4 Detector	[I]	W	Ped Detector 8	[I]
X	Flashing Logic Out	[O]	X	Preempt 5 Detector	[I]	X	φ8 Hold Off	[I]
Y	Status Bit C (Ring1)	[O]	Y	φ3 Walk	[O]	Y	Force-Off (Ring 2)	[I]
Z	<b>LS 1 Yellow Ped Clear</b>	[O]	Z	φ3 Ped Clear	[O]	Z	Stop Time (Ring 2)	[I]
a	φ1 Ped Clear	[O]	a	φ3 Dont Walk	[O]	a	Inhibit Max Term (Ring 2)	[I]
b	<b>LS 2 Yellow Ped Clear</b>	[O]	b	<b>LS 4 Green Walk</b>	[O]	b	Test C	[I]
c	<b>LS 9 Green Walk</b>	[O]	c	<b>LS 4 Yell Ped Clear</b>	[O]	c	Status Bit C (Ring 2)	[O]
d	φ2 Check	[O]	d	<b>LS 10 Green Walk</b>	[O]	d	<b>LS 12 Green Walk</b>	[O]
e	φ2 Phase On	[O]	e	φ4 Phase On	[O]	e	<b>LS 8 Yellow Ped Clear</b>	[O]
f	Vehicle Detector 1	[I]	f	φ4 Phase Next	[O]	f	<b>LS 7 Green Walk</b>	[O]
g	Ped Detector 1	[I]	g	φ4 Phase Omit	[I]	g	<b>LS 6 Green Walk</b>	[O]
h	φ1 Hold	[I]	h	φ4 Hold	[I]	h	<b>LS 6 Yellow Ped Clear</b>	[O]
i	Force-Off (Ring 1)	[I]	i	φ3 Hold	[I]	i	<b>LS 5 Green Walk</b>	[O]
j	Ext Min Recall	[I]	j	φ3 Ped Omit	[I]	j	φ5 Walk	[O]
k	Manual Control Enable	[I]	k	φ6 Ped Omit	[I]	k	φ5 Check	[O]
m	Call To Non Actuate I	[I]	m	φ7 Ped Omit	[I]	m	φ5 Hold	[I]
n	Test A	[I]	n	φ8 Ped Omit	[I]	n	φ5 Phase Omit	[I]
p	AC+ (Control)	[I]	p	<b>LS 13 Yell Ped Clear</b>	[O]	p	φ6 Hold	[I]
q	I/O Mode Bit A	[I]	q	<b>LS 13 Red Dont Walk</b>	[O]	q	φ6 Phase Omit	[I]
r	Status Bit B (Ring 1)	[O]	r	φ3 Check	[O]	r	φ7 Phase Omit	[I]
s	<b>LS 1 Green Walk</b>	[O]	s	φ3 Phase On	[O]	s	φ8 Phase Omit	[I]

## Interface Connector Pin Lists

▪ Appendix J

Connector A		Connector B		Connector C	
55-Pin (Plug) Type #22-55P		55-Pin (Socket) Type #22-55S		61-Pin (Socket) Type #24-61S	
<u>PIN</u>	<u>FUNCTION</u>	<u>PIN</u>	<u>FUNCTION</u>	<u>PIN</u>	<u>FUNCTION</u>
t	φ1 Walk	t	φ3 Phase Next	t	Vehicle Detector 8
u	φ1 Check	u	<b>LS 16 Red Dont Walk</b>	u	Red Rest Mode (Ring 2)
v	φ2 Ped Omit	v	Preempt 6 Detector	v	Omit Red Clear (Ring 2)
w	Omit AllRed Clr(Ring1)	w	<b>LS 16 Green Walk</b>	w	<b>LS 12 Yellow Ped Clear</b>
x	Red Rest (Ring 1)	x	φ4 Ped Omit	x	<b>LS 8 Green Walk</b>
y	I/O Mode Bit B	y	Free (No Coord)	y	φ7 Dont Walk
z	Call To Non Act II	z	MaxII Select(Ring 2)	z	<b>LS 11 Red Dont Walk</b>
AA	Test B	AA	<b>LS 13 Green Walk</b>	AA	<b>LS 11 Yellow Ped Clear</b>
BB	Walk Rest Modifier	BB	<b>LS 14 Yel Ped Clear</b>	BB	φ6 Check
CC	Status Bit A (Ring 1)	CC	<b>LS 14 Red Dont Walk</b>	CC	φ6 Phase On
DD	φ1 Phase On	DD	<b>LS 15 Red Dont Walk</b>	DD	φ6 Phase Next
EE	φ1 Ped Omit	EE	<b>LS 16 Yel Ped Clear</b>	EE	φ7 Hold
FF	Ped Recycle (Ring 1)	FF	<b>LS 15 Green Walk</b>	FF	φ8 Check
GG	Max II Select(Ring 1)	GG	<b>LS 14 Green Walk</b>	GG	φ8 Phase On
HH	I/O Mode Bit C	HH	<b>LS 15 Yel Ped Clear</b>	HH	φ8 Phase Next
				JJ	φ7 Walk
				KK	φ7 Ped Clear
				LL	<b>LS 11 Green Walk</b>
				MM	φ7 Check
				NN	φ7 Phase On
				PP	φ7 Phase Next

## I/O Mode Bits (3 per unit)

Mode #	Bit States			State Names
	A	B	C	
0	OFF	OFF	OFF	TS 1 Compatible
1	ON	OFF	OFF	Hardwire Interconnect
2	OFF	ON	OFF	System Interface
3	ON	ON	OFF	Reserved
4	OFF	OFF	ON	Reserved
5	ON	OFF	ON	Reserved
6	OFF	ON	ON	Manufacturer Specific
7	ON	ON	ON	Manufacturer Specific

Voltage Levels: OFF = +24 ON = 0V

I/O Pin	I/O Functions		
	Mode 0	Mode 1	Mode 2
<b>Inputs</b>			
A-h	Phase 1 Hold	Preempt 1	Preempt 1
A-M	Phase 2 Hold	Preempt 3	Preempt 3
B-i	Phase 3 Hold	Vehicle Detector 9	Vehicle Detector 9
B-h	Phase 4 Hold	Vehicle Detector 10	Vehicle Detector 10
C-m	Phase 5 Hold	Vehicle Detector 13	Vehicle Detector 13
C-p	Phase 6 Hold	Vehicle Detector 14	Vehicle Detector 14
C-EE	Phase 7 Hold	Vehicle Detector 15	Vehicle Detector 15
C-X	Phase 8 Hold	Vehicle Detector 16	Vehicle Detector 16
B-U	Phase 1 Phase Omit	Vehicle Detector 11	Vehicle Detector 11
B-S	Phase 2 Phase Omit	Vehicle Detector 12	Vehicle Detector 12
B-R	Phase 3 Phase Omit	Timing Plan C	Vehicle Detector 17
B-g	Phase 4 Phase Omit	Timing Plan D	Vehicle Detector 18
C-n	Phase 5 Phase Omit	Alternate Sequence A	Vehicle Detector 19
C-q	Phase 6 Phase Omit	Alternate Sequence B	Vehicle Detector 20
C-r	Phase 7 Phase Omit	Alternate Sequence C	Alarm 1
C-s	Phase 8 Phase Omit	Alternate Sequence D	Alarm 2
A-EE	Phase 1 Ped Omit	Dimming Enable	Dimming Enable
A-v	Phase 2 Ped Omit	Automatic Flash	Local Flash Status
B-j	Phase 3 Ped Omit	Timing Plan A	Address Bit 0
B-x	Phase 4 Ped Omit	Timing Plan B	Address Bit 1
B-T	Phase 5 Ped Omit	Offset 1	Address Bit 2
B-k	Phase 6 Ped Omit	Offset 2	Address Bit 3
B-m	Phase 7 Ped Omit	Offset 3	Address Bit 4
B-n	Phase 8 Ped Omit	TBC On Line	MMU Flash Status

▪ Appendix J

I/O Pin	I/O Functions		
	Mode 0	Mode 1	Mode 2
<b>Outputs</b>			
A-DD	Phase 1 Phase On	Preempt 1 Status	Preempt 1 Status
A-e	Phase 2 Phase On	Preempt 3 Status	Preempt 3 Status
B-s	Phase 3 Phase On	TBC Auxiliary 1	TBC Auxiliary 1
B-e	Phase 4 Phase On	TBC Auxiliary 2	TBC Auxiliary 2
C-N	Phase 5 Phase On	Timing Plan A	Timing Plan A
C-CC	Phase 6 Phase On	Timing Plan B	Timing Plan B
C-NN	Phase 7 Phase On	Offset 1	Offset 1
C-GG	Phase 8 Phase On	Offset 2	Offset 2
B-A	Phase 1 Phase Next	Preempt 2 Status	Preempt 2 Status
B-C	Phase 2 Phase Next	Preempt 4 Status	Preempt 4 Status
B-t	Phase 3 Phase Next	Preempt 5 Status	Preempt 5 Status
B-f	Phase 4 Phase Next	Preempt 6 Status	Preempt 6 Status
C-M	Phase 5 Phase Next	Offset 3	Offset 3
C-DD	Phase 6 Phase Next	Timing Plan C	Timing Plan C
C-PP	Phase 7 Phase Next	Timing Plan D	Timing Plan D
C-HH	Phase 8 Phase Next	Reserved	Reserved
A-u	Phase 1 Check	Free/Coord Status	Free/Coord Status
A-d	Phase 2 Check	Automatic Flash	Automatic Flash
B-r	Phase 3 Check	TBC Auxiliary 3	TBC Auxiliary 3
B-K	Phase 4 Check	Reserved	Reserved
C-k	Phase 5 Check	Reserved	System Special Function 1
C-BB	Phase 6 Check	Reserved	System Special Function 2
C-MM	Phase 7 Check	Reserved	System Special Function 3
C-FF	Phase 8 Check	Reserved	System Special Function 4

## Connector D

PIN	Function	Secondary Function	I/O	Notes
7	KEY POSITION			
60	AUTOMATIC FLASH		[I]	
58	ABSOLUTE STOP TIME		[I]	
14	CONTROLLER TIME RESET		[I]	
26	FORCE COORDINATOR FREE		[I]	
17	DETECTOR #09		[I]	
47	DETECTOR #10		[I]	
31	DETECTOR #11		[I]	
18	DETECTOR #12		[I]	
30	DETECTOR #13		[I]	
39	DETECTOR #14		[I]	
40	DETECTOR #15		[I]	
13	DETECTOR #16		[I]	
38	FORCE DUAL COORDINATION		[I]	
25	EXT SYS CMD CYCLE BIT 1 IN		[I]	
35	EXT SYS CMD CYCLE BIT 2 IN		[I]	
6	EXT SYS CMD CYCLE BIT 3 IN		[I]	
12	EXT SYS CMD OFFSET BIT 1 IN	EXT ADDRESS BIT 0	[I]	
10	EXT SYS CMD OFFSET BIT 2 IN	EXT ADDRESS BIT 1	[I]	
36	EXT SYS CMD OFFSET BIT 3 IN	EXT ADDRESS BIT 2	[I]	
16	EXT SYS CMD SPLIT BIT 1 IN	EXT ADDRESS BIT 3	[I]	
9	EXT SYS CMD SPLIT BIT 2 IN	EXT ADDRESS BIT 4	[I]	
4	EXT SYS CMD SYNC INPUT		[I]	
57	PREEMPTOR CALL #1 RR1		[I]	
49	PREEMPTOR CALL #2 RR2		[I]	
50	PREEMPTOR CALL #3 EVP A	/BUS PREEMPTOR #1	[I]	
55	PREEMPTOR CALL #4 EVP B	/BUS PREEMPTOR #2	[I]	
56	PREEMPTOR CALL #5 EVP C	/BUS PREEMPTOR #3	[I]	
61	PREEMPTOR CALL #6 EVP D	/BUS PREEMPTOR #4	[I]	
3	SPLIT DEMAND 1 INPUT		[I]	
20	TEST INPUT C		[I]	
37	TEST INPUT D		[I]	
19	TEST INPUT E		[I]	
27	COORDINATOR STATUS OUT		[O]	

## Interface Connector Pin Lists

▪ Appendix J

PIN	Function	Secondary Function	I/O	Notes
5	CROSS STREET SYNC OUT		[O]	
43	INT SYS STATUS CYCLE BIT 1 OUT		[O]	
44	INT SYS STATUS CYCLE BIT 2 OUT		[O]	
29	INT SYS STATUS CYCLE BIT 3 OUT		[O]	
33	INT SYS STATUS OFFSET BIT 1 OUT		[O]	
42	INT SYS STATUS OFFSET BIT 2 OUT		[O]	
2	INT SYS STATUS OFFSET BIT 3 OUT		[O]	
21	INT SYS STATUS SPLIT BIT 1 OUT		[O]	
46	INT SYS STATUS SPLIT BIT 2 OUT		[O]	
53	INT SYS STATUS SYNC OUT		[O]	
59	PMT/CTR TO CABINET INTERLOCK		[O]	
23	PREEMPTOR #1 ACTIVE		[O]	Priority preemptors 1 & 2 respond to any NEMA defined input applied to Preemptor Call input 1 & 2, respectively.
32	PREEMPTOR #2 ACTIVE		[O]	
22	PREEMPTOR #3 EVP A ACTIVE		[O]	Priority preemptors 3-6 respond to any NEMA defined input applied for at least 0.8 seconds to Preemptor Call inputs 3-6, respectively. Bus Preemptors 1-4 respond to a pulsing (1pps at 50% duty cycle) NEMA defined input applied to Preemptor Call input 3-6, respectively.
34	PREEMPTOR #4 EVP B ACTIVE		[O]	
1	PREEMPTOR #5 EVP C ACTIVE		[O]	
48	PREEMPTOR #6 EVP D ACTIVE		[O]	
15	PREEMPTOR FLASH CONTROL	(1K PULL UP)	[O]	
41	SPARE OUTPUT 4		[O]	
45	SPARE OUTPUT 5		[O]	
51	SPARE OUTPUT 6		[O]	
52	SPARE OUTPUT 7		[O]	
54	SPARE OUTPUT 8		[O]	
28	TOD SPECIAL FUNCTION 1		[O]	
8	TOD SPECIAL FUNCTION 2		[O]	
24	TOD SPECIAL FUNCTION 3/	SPARE OUTPUT 1	[O]	
11	TOD SPECIAL FUNCTION 4/	SPARE OUTPUT 2	[O]	



## Port 3B 25-pin Telemetry Connector

PIN	Function	I/O	FSK	Serial
1	SYSTEM DETECTOR C2	[I]		
2	SYSTEM DETECTOR A2	[I]		
3	SYSTEM DETECTOR A1	[I]		
4	SYSTEM DETECTOR C1	[I]		
5	SYSTEM DETECTOR B1	[I]		
6	TLM SPARE 2	[I]		
7	SYSTEM DETECTOR D1	[I]		
8	SYSTEM DETECTOR D2	[I]		
9	TLM SPECIAL FUNCTION 1	[O]		
10	TLM SPECIAL FUNCTION 3	[O]		
11	Key Position	-		
12	TRANSMIT 1	[O]		
13	TRANSMIT 2	[O]		
14	TLM SPARE 1	[I]		
15	EXTERNAL ADDRESS ENABLE	[I]		
16	DOOR OPEN	[I]		
17	ALARM 1	[I]		
18	LOCAL FLASH	[I]		
19	SYSTEM DETECTOR B2	[I]		
20	CONFLICT FLASH	[I]		
21	ALARM 2	[I]		
22	TLM SPECIAL FUNCTION 2	[O]		
23	TLM SPECIAL FUNCTION 4	[O]		
24	RECEIVE 1	[O]		
25	RECEIVE 2	[O]		

## CU Port 1 SDLC

PIN	CU Function	I/O	Notes	Other Port 1
1	Tx Data +	[O]		Rx Data +
2	Logic Ground	[-]		
3	Tx Clock +	[O]		Rx Clock +
4	Logic Ground	[-]		
5	Rx Data +	[I]		Tx Data +
6	Logic Ground	[-]		
7	Rx Clock +	[I]		Tx Clock +
8	Logic Ground	[-]		
9	Tx Data -	[O]		Rx Data -
10	Port 1 Disable	[I]	(OVDC=disable)	
11	Tx Clock -	[O]		Rx Clock -
12	Chassis Ground	[-]		Chassis Ground
13	Rx Data -	[I]		Tx Data -
14	Reserved			
15	Rx Clock -	[I]		Tx Clock -
<p><b>NOTE:</b>                      TX pins at the BIU are RX pins at the controller.                      RX pins at the BIU are TX pins at the controller.</p>				

## Type 1 Power

PIN	Function	I/O
A	AC Neutral	[I]
B	Not Used	
C	AC Line	[I]
D	Not Used	
E	Not Used	
F	Fault Monitor	[O]
G	Logic Ground	[O]
H	Chassis Ground	[I]
I	Not Used	
J	Not Used	

## Port 2/C50S Terminal

PIN	Function	I/O
1	GND Chassis Ground	[-]
2	TXD Transmit Data	[O]
3	RXD Receive Data	[I]
4	RTS Request To Send	[O]
5	CTS Clear To Send	[I]
6	Not Used	
7	GND Logic Ground	[-]
8	DCD Data Carrier Det	[I]
9-19	Not Used	
20	DTR Data Termnl Ready	[O]
21-25	Not Used	

## Port 3A EIA-232 Telemetry

PIN	Function		I/O
1	CTS	Clear To Send	[I]
2	RXD	Receive Data	[I]
3	TXD	Transmit Data	[O]
4	DTR	Data Termnl Ready	[O]
5	GND	Logic Ground	[-]
6	DSR	Data Set Ready	[O]
7	RTS	Request To Send	[O]
8	Not Used		
9	Not Used		

## Port 3B 9-pin FSK Telemetry Connector

PIN	Function		I/O
1	TXD+	Transmit 2	[O]
2	TXD-	Transmit 2	[O]
3	Reserved		
4	RXD+	Receive 1	[I]
5	RXD-	Receive 2	[I]
6		Chassis Ground	[-]
7	Reserved		
8	Reserved		
9		Chassis Ground	[-]

Equipment	170 Controller C1 Default Assignment Per Safetran Cabinet Standard
Connectivity	Controller Type ASC/3-RM or 2070 2A - C1 Connector

Pin # - Input	Safetran 332	Safetran 330 TBD	Safetran 336 TBD	Safetran 303 TBD	Safetran 337 TBD
Pin 39	VEHICLE DET 02				
Pin 40	VEHICLE DET 18				
Pin 41	VEHICLE DET 06				
Pin 42	VEHICLE DET 22				
Pin 43	VEHICLE DET 10				
Pin 44	VEHICLE DET 26				
Pin 45	VEHICLE DET 14				
Pin 46	VEHICLE DET 30				
Pin 47	VEHICLE DET 04				
Pin 48	VEHICLE DET 20				
Pin 49	VEHICLE DET 08				
Pin 50	VEHICLE DET 24				
Pin 51	PREEMPT CALL 1				
Pin 52	PREEMPT CALL 2				
Pin 53	MAN CONT ENA				
Pin 54	TEST A				
Pin 55	VEHICLE DET 17				
Pin 56	VEHICLE DET 01				
Pin 57	VEHICLE DET 21				
Pin 58	VEHICLE DET 05				
Pin 59	VEHICLE DET 25				
Pin 60	VEHICLE DET 09				
Pin 61	VEHICLE DET 29				
Pin 62	VEHICLE DET 13				
Pin 63	VEHICLE DET 03				
Pin 64	VEHICLE DET 19				
Pin 65	VEHICLE DET 07				
Pin 66	VEHICLE DET 23				
Pin 67	PED DET 02				
Pin 68	PED DET 06				
Pin 69	PED DET 04				
Pin 70	PED DET 08				
Pin 71	PREEMPT CALL 3				
Pin 72	PREEMPT CALL 4				
Pin 73	PREEMPT CALL 5				
Pin 74	PREEMPT CALL 6				
Pin 75	SPLIT DEMAND 1				
Pin 76	VEHICLE DET 11				
Pin 77	VEHICLE DET 27				
Pin 78	VEHICLE DET 15				
Pin 79	VEHICLE DET 31				
Pin 80	INT ADV				
Pin 81	LOCAL FLASH				
Pin 82	STOP TIME				

**For your notes:**

Pin # - Output	Safetran 332	Safetran 330 TBD	Safetran 336 TBD	Safetran 303 TBD	Safetran 337 TBD
Pin 2	PH 4 DON'T WLK				
Pin 3	PH 4 WALK				
Pin 4	PH 4 RED				
Pin 5	PH 4 YELLOW				
Pin 6	PH 4 GREEN				
Pin 7	PH 3 RED				
Pin 8	PH 3 YELLOW				
Pin 9	PH 3 GREEN				
Pin 10	PH 2 DON'T WLK				
Pin 11	PH 2 WALK				
Pin 12	PH 2 RED				
Pin 13	PH 2 YELLOW				
Pin 15	PH 2 GREEN				
Pin 16	PH 1 RED				
Pin 17	PH 1 YELLOW				
Pin 18	PH 1 GREEN				
Pin 19	PH 8 DON'T WLK				
Pin 20	PH 8 WALK				
Pin 21	PH 8 RED				
Pin 22	PH 8 YELLOW				
Pin 23	PH 8 GREEN				
Pin 24	PH 7 RED				
Pin 25	PH 7 YELLOW				
Pin 26	PH 7 GREEN				
Pin 27	PH 6 DON'T WLK				
Pin 28	PH 6 WALK				
Pin 29	PH 6 RED				
Pin 30	PH 6 YELLOW				
Pin 31	PH 6 GREEN				
Pin 32	PH 5 RED				
Pin 33	PH 5 YELLOW				
Pin 34	PH 5 GREEN				
Pin 35	OLA GREEN				
Pin 36	OLB GREEN				
Pin 37	OLA YELLOW				
Pin 38	OVERLAP B YELLOW				
Pin 83	TOD SPEC FUNC 1				
Pin 84	TOD SPEC FUNC 3				
Pin 85	OLD RED				
Pin 86	OLD YELLOW				
Pin 87	OLD GREEN				
Pin 88	OLC RED				
Pin 89	OLC YELLOW				
Pin 90	OLC GREEN				

Pin # - Output	Safetran 332	Safetran 330 TBD	Safetran 336 TBD	Safetran 303 TBD	Safetran 337 TBD
Pin 91	COORD FREE STAT				
Pin 93	CRD SYNC OUT				
Pin 94	OLB RED				
Pin 95	OLB YELLOW				
Pin 96	OLB GREEN				
Pin 97	OLA RED				
Pin 98	OLA YELLOW				
Pin 99	OLA GREEN				
Pin 100	TOD SPEC FUNC 2				
Pin 101	AUTOMATIC FLASH				
Pin 102	TOD SPEC FUNC 4				
Pin 103	WATCHDOG				

---

**For your notes:**





## BIU Connector Pin Lists

Pin	Function	TF #1 Function	TF #2 Function	TF #3 Function	TF #4 Function
1a	+24 VDC IN				
1b	+24 VDC IN				
2a	Output 1	Load Switch 1 Red Driver	Load Switch 9 Red Driver	Timing Plan A Output	Phase 1 On
2b	Output 2	Load Switch 1 Yellow Driver	Load Switch 9 Yellow Driver	Timing Plan B Output	Phase 2 On
3a	Output 3	Load Switch 1 Green Driver	Load Switch 9 Green Driver	Timing Plan C Output	Phase 3 On
3b	Output 4	Load Switch 2 Red Driver	Load Switch 10 Red Driver	Timing Plan D Output	Phase 4 On
4a	Output 5	Load Switch 2 Yellow Driver	Load Switch 10 Yellow Driver	Offset 1 Output	Phase 5 On
4b	Output 6	Load Switch 2 Green Driver	Load Switch 10 Green Driver	Offset 2 Output	Phase 6 On
5a	Output 7	Load Switch 3 Red Driver	Load Switch 11 Red Driver	Offset 3 Output	Phase 7 On
5b	Output 8	Load Switch 3 Yellow Driver	Load Switch 11 Yellow Driver	Automatic Flash	Phase 8 On
6a	Output 9	Load Switch 3 Green Driver	Load Switch 11 Green Driver	System Special Func 1	Phase 1 Next
6b	Output 10	Load Switch 4 Red Driver	Load Switch 12 Red Driver	System Special Func 2	Phase 2 Next
7a	Output 11	Load Switch 4 Yellow Driver	Load Switch 12 Yellow Driver	System Special Func 3	Phase 3 Next
7b	Output 12	Load Switch 4 Green Driver	Load Switch 12 Green Driver	System Special Func 4	Phase 4 Next
8a	Output 13	Load Switch 5 Red Driver	Load Switch 13 Red Driver	Reserved	Phase 5 Next
8b	Output 14	Load Switch 5 Yellow Driver	Load Switch 13 Yellow Driver	Reserved	Phase 6 Next
9a	Output 15	Load Switch 5 Green Driver	Load Switch 13 Green Driver	Reserved	Phase 7 Next
9b	Input/Output 1	Load Switch 6 Red Driver [O]	Load Switch 14 Red Driver [O]	Ring 1 Status Bit A [O]	Phase 8 Next [O]
10a	Input/Output 2	Load Switch 6 Yellow Driver [O]	Load Switch 14 Yellow Driver [O]	Ring 1 Status Bit B [O]	Phase 1 Check [O]
10b	Input/Output 3	Load Switch 6 Green Driver [O]	Load Switch 14 Green Driver [O]	Ring 1 Status Bit C [O]	Phase 2 Check [O]
11a	Input/Output 4	Load Switch 7 Red Driver [O]	Load Switch 15 Red Driver [O]	Ring 2 Status Bit A [O]	Phase 3 Check [O]
11b	Input/Output 5	Load Switch 7 Yellow Driver [O]	Load Switch 15 Yellow Driver [O]	Ring 2 Status Bit B [O]	Phase 4 Check [O]
12a	Input/Output 6	Load Switch 7 Green Driver [O]	Load Switch 15 Green Driver [O]	Ring 2 Status Bit C [O]	Phase 5 Check [O]
12b	Input/Output 7	Load Switch 8 Red Driver [O]	Load Switch 16 Red Driver [O]	Red Rest Ring 1 [I]	Phase 6 Check [O]
13a	Input/Output 8	Load Switch 8 Yellow Driver [O]	Load Switch 16 Yellow Driver [O]	Red Rest Ring 2 [I]	Phase 7 Check [O]
13b	Input/Output 9	Load Switch 8 Green Driver [O]	Load Switch 16 Green Driver [O]	Omit All Red Ring 1 [I]	Phase 8 Check [O]
14a	Input/Output 10	TBC Aux #1 Output [O]	TBC Aux #3 Output [O]	Omit All Red Ring 2 [I]	Address Bit 0 [I]
14b	Input/Output 11	TBC Aux #2 Output [O]	Free/Coord Status [O]	Ped Recycle Ring 1 [I]	Address Bit 1 [I]
15a	Input/Output 12	Preempt 1 Output [O]	Preempt 3 Output [O]	Ped Recycle Ring 2 [I]	Address Bit 2 [I]

## BIU Connector Pin Lists

▪ Appendix K

Pin	Function	TF #1 Function	TF #2 Function	TF #3 Function	TF #4 Function
15b	Input/Output 13	Preempt 2 Output [O]	Preempt 4 Output [O]	Alternate Sequence A[I]	Address Bit 3[I]
16a	Input/Output 14	Preempt 1 Input [I]	Preempt 5 Output [O]	Alternate Sequence B[I]	Address Bit 4[I]
16b	Input/Output 15	Preempt 2 Input [I]	Preempt 6 Output [O]	Alternate Sequence C[I]	Spare
17a	Input/Output 16	Test Input A [I]	Preempt 3 Input [I]	Alternate Sequence D[I]	Spare
17b	Input/Output 17	Test Input B [I]	Preempt 4 Input [I]	Phase Omit 1[I]	Spare
18a	Input/Output 18	Automatic Flash [I]	Preempt 5 Input [I]	Phase Omit 2[I]	Spare
18b	Input/Output 19	Dimming Enable [I]	Preempt 6 Input [I]	Phase Omit 3[I]	Spare
19a	Input/Output 20	Manual Control Enable [I]	Call To Nonactuated II [I]	Phase Omit 4[I]	Reserved
19b	Input/Output 21	Interval Advance [I]	Spare	Phase Omit 5[I]	Reserved
20a	Input/Output 22	External Minimum Recall [I]	Spare	Phase Omit 6[I]	Reserved
20b	Input/Output 23	External Start [I]	Spare	Phase Omit 7[I]	Reserved
21a	Input/Output 24	TBC ON Line [I]	Spare	Phase Omit 8[I]	Reserved
21b	Input 1	Stop Time Ring 1 (Stop Time)	Inhibit Max Ring 1	Hold Phase 1	Ped Omit 1
22a	Input 2	Stop Time Ring 2	Inhibit Max Ring 2	Hold Phase 2	Ped Omit 2
22b	Input 3	Max II Selection Ring 1	Local Flash	Hold Phase 3	Ped Omit 3
23a	Input 4	Max II Selection Ring 2	MMU Flash	Hold Phase 4	Ped Omit 4
23b	Input 5	Force Off Ring 1 (Force Off)	Alarm 1	Hold Phase 5	Ped Omit 5
24a	Input 6	Force Off Ring 2	Alarm 2	Hold Phase 6	Ped Omit 6
24b	Input 7	Call To Non Act I	Free (No Coord)	Hold Phase 7	Ped Omit 7
25a	Input 8	Walk Rest Modifier	Test Input C	Hold Phase 8	Ped Omit 8
25b	Opto Input 1	Phase 1 Ped Call	Phase 5 Ped Call (Signal Plan A)	Timing Plan A Input	Offset 1 Input
26a	Opto Input 2	Phase 2 Ped Call	Phase 6 Ped Call (Signal Plan B)	Timing Plan B Input	Offset 2 Input
26b	Opto Input 3	Phase 3 Ped Call	Phase 7 Ped Call	Timing Plan C Input	Offset 3 Input
27a	Opto Input 4	Phase 4 Ped Call	Phase 8 Ped Call	Timing Plan D Input	Spare
27b	Opto Common	12 VAC	12 VAC	Interconnect Common	Interconnect Common
28a	Address Select 0	Open	Logic GND	Open	Log GND
28b	Address Select 1	Open	Open	Logic GND	Log GND
29a	Address Select 2	Open	Open	Open	Open
29b	Address Select 3	Open	Open	Open	Open
30a					
30b	Data Transmit				
31b	Data Receive				
31a	Line Frequency				
32b	Logic Ground				

Pin	Function	DET #1 Function	DET #2 Function	DET #3 Function	DET #4 Function
1a	+24 VDC IN				
1b	+24 VDC IN				
2a	Output 1	Detector Reset Slot ½			
2b	Output 2	Detector Reset Slot 3/4			
3a	Output 3	Detector Reset Slot 5/6			
3b	Output 4	Detector Reset Slot 7/8			
4a	Output 5	Reserved			
4b	Output 6	Reserved			
5a	Output 7	Reserved			
5b	Output 8	Reserved			
6a	Output 9	Reserved			
6b	Output 10	Reserved			
7a	Output 11	Reserved			
7b	Output 12	Reserved			
8a	Output 13	Reserved			
8b	Output 14	Reserved			
9a	Output 15	Reserved			
9b	Input/Output 1	Channel 1 Call[I]	Channel 17 Call [I]	Channel 33 Call[I]	Channel 49 Call[I]
10a	Input/Output 2	Channel 2 Call[I]	Channel 18 Call [I]	Channel 34 Call[I]	Channel 50 Call[I]
10b	Input/Output 3	Channel 3 Call[I]	Channel 19 Call [I]	Channel 35 Call[I]	Channel 51Call[I]
11a	Input/Output 4	Channel 4 Call[I]	Channel 20 Call [I]	Channel 36 Call[I]	Channel 52 Call[I]
11b	Input/Output 5	Channel 5 Call[I]	Channel 21 Call [I]	Channel 37 Call[I]	Channel 53 Call[I]
12a	Input/Output 6	Channel 6 Call[I]	Channel 22 Call [I]	Channel 38 Call[I]	Channel 54 Call[I]
12b	Input/Output 7	Channel 7 Call[I]	Channel 23 Call [I]	Channel 39 Call[I]	Channel 55 Call[I]
13a	Input/Output 8	Channel 8 Call[I]	Channel 24 Call [I]	Channel 40 Call[I]	Channel 56 Call[I]
13b	Input/Output 9	Channel 9 Call[I]	Channel 25 Call [I]	Channel 41 Call[I]	Channel 57 Call[I]
14a	Input/Output 10	Channel 10 Call[I]	Channel 26 Call [I]	Channel 42 Call[I]	Channel 58 Call[I]
14b	Input/Output 11	Channel 11 Call[I]	Channel 27 Call [I]	Channel 43 Call[I]	Channel 59 Call[I]
15a	Input/Output 12	Channel 12 Call[I]	Channel 28 Call [I]	Channel 44 Call[I]	Channel 60 Call[I]
15b	Input/Output 13	Channel 13 Call[I]	Channel 29 Call [I]	Channel 45 Call[I]	Channel 61 Call[I]
16a	Input/Output 14	Channel 14 Call[I]	Channel 30 Call [I]	Channel 46 Call[I]	Channel 62 Call[I]
16b	Input/Output 15	Channel 15 Call[I]	Channel 31 Call [I]	Channel 47 Call[I]	Channel 63 Call[I]

## BIU Connector Pin Lists

▪ Appendix K

Pin	Function	DET #1 Function	DET #2 Function	DET #3 Function	DET #4 Function
17a	Input/Output 16	Channel 16 Call[!]	Channel 32 Call [!]	Channel 48 Call[!]	Channel 64 Call[!]
17b	Input/Output 17	Channel 1 Fault Status[!]	Channel 17 Fault Status [!]	Channel 33 Fault Status [!]	Channel 49 Fault Status [!]
18a	Input/Output 18	Channel 2 Fault Status[!]	Channel 18 Fault Status [!]	Channel 34 Fault Status [!]	Channel 50 Fault Status [!]
18b	Input/Output 19	Channel 3 Fault Status[!]	Channel 19 Fault Status [!]	Channel 35 Fault Status [!]	Channel 51 Fault Status [!]
19a	Input/Output 20	Channel 4 Fault Status[!]	Channel 20 Fault Status [!]	Channel 36 Fault Status [!]	Channel 52 Fault Status [!]
19b	Input/Output 21	Channel 5 Fault Status[!]	Channel 21 Fault Status [!]	Channel 37 Fault Status [!]	Channel 53 Fault Status [!]
20a	Input/Output 22	Channel 6 Fault Status[!]	Channel 22 Fault Status [!]	Channel 38 Fault Status [!]	Channel 54 Fault Status [!]
20b	Input/Output 23	Channel 7 Fault Status[!]	Channel 23 Fault Status [!]	Channel 39 Fault Status [!]	Channel 55 Fault Status [!]
21a	Input/Output 24	Channel 8 Fault Status[!]	Channel 24 Fault Status [!]	Channel 40 Fault Status [!]	Channel 56 Fault Status [!]
21b	Input 1	Channel 9 Fault Status	Channel 25 Fault Status	Channel 41 Fault Status	Channel 57 Fault Status
22a	Input 2	Channel 10 Fault Status	Channel 26 Fault Status	Channel 42 Fault Status	Channel 58 Fault Status
22b	Input 3	Channel 11 Fault Status	Channel 27 Fault Status	Channel 43 Fault Status	Channel 59 Fault Status
23b	Input 4	Channel 12 Fault Status	Channel 28 Fault Status	Channel 44 Fault Status	Channel 60 Fault Status
23a	Input 5	Channel 13 Fault Status	Channel 29 Fault Status	Channel 45 Fault Status	Channel 61 Fault Status
24b	Input 6	Channel 14 Fault Status	Channel 30 Fault Status	Channel 46 Fault Status	Channel 62 Fault Status
24a	Input 7	Channel 15 Fault Status	Channel 31 Fault Status	Channel 47 Fault Status	Channel 63 Fault Status
25a	Input 8	Channel 16 Fault Status	Channel 32 Fault Status	Channel 48 Fault Status	Channel 64 Fault Status
25b	Opto Input 1	Reserved			
26a	Opto Input 2	Reserved			
26b	Opto Input 3	Reserved			
27a	Opto Input 4	Reserved			
27b	Opto Common	Reserved			
28b	Address Select 0	-	Logic GND	-	Logic GND
28a	Address Select 1	-	-	Logic GND	Logic GND
29b	Address Select 2	-	-	-	-
29a	Address Select 3	Logic GND	Logic GND	Logic GND	Logic G
30b	Data Transmit (reserved)				
30a	Data Receive (reserved)				
31b	Earth Ground				
31a	Line Frequency Ref.				
32b	Logic Ground				



# Logic Processor Operation

## Introduction

The Logic Processor provides a means to command the controller inputs and outputs based upon a set of Logical Elements. This increases the flexibility of the controller and allows the knowledgeable user to implement and verify modifications to the operation of the *ASC/3*.

Each Logic Processor Statement (LPS) can be controlled by manual data entry (MM-1-8-1), Time Base Action Plan (MM-5-4), or Remote Command. It is recommended that the LPSs that are being developed be programmed in MM-1-8-1 as “D” (disabled). Once the complete operation is developed and ready for evaluation, the statements can be programmed as “E” (enabled). When the LPSs operate correctly, the statements can be left enabled or can be put under Time Base action plan (MM-1-5-4) control (“.”).

---

**IMPORTANT** • The controller must be on the bench and not operating an intersection when the Logic Processor is being programmed. Changing an LPS will force transaction mode for additional safety.

---

The format of Logic Processor Statements is based upon IF-THEN-ELSE elements. A Logic Processor Statement is divided into the following parts:

Name	Type	Description
LP #	n/a	Logic Processor statement number.
IF	Testable element	Up to 10 elements can be programmed in the IF condition. Multiple elements must be separated by a logical operator (below).
<i>logical operator</i>	Testable element	Logical operator lines are optional. After the first Testable element, additional Testable elements must be preceded by a logical operator (AND, OR, NAND, NOR, XOR).
THEN	Executable element	Up to 5 THEN elements can be programmed.
ELSE	Executable element	Up to 5 ELSE elements can be programmed.

For example: IF x THEN y ELSE z

### ▪ Appendix L

Several LP statements can be linked together as “Linked LP Statements” to perform a unique function. The order of LPSs is critical for correct operation.

The *ASC/3* evaluates each statement every *one tenth* of a second, in top-down order. When a Logic Processor statement requires information that is developed by another statement, that information must be developed in an earlier statement.

A total of 200 LPSs are available for programming. Statements 1-100 are enabled and disabled via the Controller menus MM-1-8-1 and MM-5-4. Statements 101-200 are Extended Options and must be enabled in a special file called *ASC3 .EXT*. (For more information about programming statements 101-200, refer to *Extended Logic Processor Group* on page 6-64.)

Defining each statement is done in MM-1-8-2. However, statements 101-200 cannot be accessed on an actual *ASC/3* controller; instead, statements 101-200 must be programmed using the *ASC/3* Controller Configurator run on a PC.

## General LP Programming Operation

### *IF Condition – Testable Elements*

The LP (Logic Processor) IF elements can determine the state of selected internal timers, states, CIB (Controller Input Buffer) and COB (Controller Output Buffer) locations. Also, the controller mapping may determine whether or not the result of the LPS causes an output to the field or an input from the field. For example, if the LPS is testing Preemption 10 input but there is no connector input pin 00 mapped to that location, the LPS will never see a change to that location in the CIB.

Each IF condition is comprised of up to 10 testable elements. Testable elements are conditions within the controller that can be evaluated to be either true or false. Examples of testable elements include:

- VEH GREEN ON PH 2
- DET #1 IS ON
- PMT DELAY TIMER > 5 seconds (where > means “is greater than”)
- COORDINATION PLAN IS FREE

These testable elements can be linked together to form an IF condition. Because each testable element results in either a true or false condition, linking of several testable elements into an IF condition will result in an overall true or false condition.

Linking occurs through the following logical operators:

Operator	Description
AND	The result is true only if both elements are true.
OR	The result is true if at least one element is true.
NAND	The result is false only if both elements are true.
NOR	The result is true only if both elements are false.
XOR	The result is true if one element (but not both) is true.

The following table shows the results for these logical operations:

Statement 1	Operator	Statement 2	Result
TRUE	AND	TRUE	TRUE
TRUE	AND	FALSE	FALSE
FALSE	AND	TRUE	FALSE
FALSE	AND	FALSE	FALSE
TRUE	OR	TRUE	TRUE
TRUE	OR	FALSE	TRUE
FALSE	OR	TRUE	TRUE
FALSE	OR	FALSE	FALSE
TRUE	NAND	TRUE	FALSE
TRUE	NAND	FALSE	TRUE
FALSE	NAND	TRUE	TRUE
FALSE	NAND	FALSE	TRUE
TRUE	NOR	TRUE	FALSE
TRUE	NOR	FALSE	FALSE
FALSE	NOR	TRUE	FALSE
FALSE	NOR	FALSE	TRUE
TRUE	XOR	TRUE	FALSE
TRUE	XOR	FALSE	TRUE
FALSE	XOR	TRUE	TRUE
FALSE	XOR	FALSE	FALSE

▪ Appendix L

For example, several testable elements can be linked in the IF condition as:

- (1) **IF** Phase 2 Green is ON
- (2) **AND** Vehicle Detector #1 is ON
- (3) **OR** Preempt Delay Timer > 5 seconds
- (4) **OR** Coord Plan is FREE

Every *one tenth* of a second, this expression is evaluated to either true or false.

Testable elements are evaluated from top to bottom. In this example, elements (1) and (2) are evaluated first, and the result is evaluated against element (3); this result is then evaluated against element (4). This process continues for all testable elements in the IF condition.

Using the previous example, assume that:

- phase 2 is green
- vehicle detector #1 is off
- the preempt delay timer is at 10 seconds
- the coord plan is *not* FREE

The results when each testable element is evaluated independently are:

Phase 2 Green is ON	==>	<b>TRUE</b>
Vehicle Detector #1 is ON	==>	<b>FALSE</b>
Preempt Delay Timer > 5 seconds	==>	<b>TRUE</b>
Coord Plan is FREE	==>	<b>FALSE</b>

When the first two testable elements are evaluated, the result is **FALSE**:

TRUE (1) AND FALSE (2) = FALSE (1,2)

When this result is evaluated against the third testable element, the result is **TRUE**:

FALSE (1,2) OR TRUE (3) = TRUE (1,2,3)

When this result is evaluated against the last testable element, the result is **TRUE**:

TRUE (1,2,3) OR FALSE (4) = TRUE (1,2,3,4)

Thus, the final result for the whole expression is **TRUE**.

The order of testable elements is *very* important. In the above example if elements 2 and 3 are reversed:

- (1) **IF** Phase 2 Green is ON
- (2) **OR** Preempt Delay Timer > 5 seconds
- (3) **AND** Vehicle Detector #1 is ON
- (4) **OR** Coord Plan is FREE

the final result for the whole expression is now **FALSE**:



When the first two testable elements are evaluated, the result is **TRUE**:

TRUE (1) OR TRUE (2) = TRUE (1,2)

When this result is evaluated against the third testable element, the result is **FALSE**:

TRUE (1,2) AND FALSE (3) = FALSE (1,2,3)

When this result is evaluated against the last testable element, the result is **FALSE**:

FALSE (1,2,3) OR FALSE (4) = FALSE (1,2,3,4)

### **THEN/ELSE – Executable Elements**

The Logic Processor THEN/ELSE statements perform several functions. For CIB (Controller Input Buffer) and COB (Controller Output Buffer) operation, the controller mapping determines whether or not the results of these elements cause an output to the field or input from the field. For example, if the executable element sets PHASE GREEN 16 ON but no pin is mapped to that element, there will be no output.

Once the result of the IF condition is determined, the THEN statement specifies what the controller does when the IF condition is true, and the ELSE statement specifies what the controller does when the IF condition is false. Each THEN/ELSE action is comprised of up to 5 executable elements.

Examples of executable elements include:

- Set Vehicle Detector #2 ON
- Delay 10 seconds
- Set Phase 10 Green output OFF

Adding these elements to the preceding example:

```
(1)      IF Phase 2 Green is ON
(2)      AND Vehicle Detector #1 is ON
(3)      OR Preempt Delay Timer > 5 seconds
(4)      OR Coord Plan is FREE
(5)      THEN Set Vehicle Detector #2 ON
(6)          Set Phase 10 Green output OFF
(7)      ELSE Set Vehicle Detector #2 OFF
(8)          Set Phase 10 Green output ON
```

when the IF condition is true, the logic processor will set vehicle detector #2 ON and phase 10 green output OFF; when the IF condition is false, the logic processor will set vehicle detector #2 OFF and phase 10 green output ON.

---

**IMPORTANT** • When phase colors are being controlled, the complete set of phase indications must be considered. In this example, the THEN element turns Phase 10 Green off. If it was on, there will be no color output for that phase. The intersection will go to a Red Fail flash condition if the controller is operating in a TS2 environment. Similarly, the ELSE element turns Phase 10 Green on. If it was off, there will be two color outputs for that phase. The intersection will go to a Dual Indication flash condition if the controller is operating in a TS2 environment.

---

### Delay Timers

Delay timers can be set as an executable element to temporarily suspend execution of certain elements. When an executable element that contains a delay interval is encountered, the delay timer will begin timing down from its programmed value. All remaining executable elements will be disregarded until the delay timer has expired. The delay timer will continue timing as long as the conditional element remains in a constant state.

---

**Note** • If the result of the IF condition changes, the delay timer will be reset.

---

Adding a delay timer to the previous example illustrates this behavior:

```
(1)    IF Phase 2 Green is ON
(2)    AND Vehicle Detector #1 is ON
(3)    OR Preempt Delay Timer > 5 seconds
(4)    OR Coord Plan is FREE
(5)    THEN Set Vehicle Detector #2 ON
        Delay 3 seconds
(6)    Set Phase 10 Green output OFF
(7)    ELSE Set Vehicle Detector #2 OFF
        Delay 5 seconds
(8)    Set Phase 10 Green output ON
```

In this example, when the IF condition is true, vehicle detector #2 turns on immediately; if the IF condition remains true for at least 3 seconds, phase 10 green output turns off. When the IF condition is false, vehicle detector #2 turns off immediately; if the IF condition remains false for at least 5 seconds, phase 10 green output turns on.

---

**Note** • When the IF condition changes value, all delay timers are reset.

---

Multiple delay timers can be placed within a single THEN statement, as shown here:

```
(1)    IF Phase 2 Green is ON
(2)    AND Vehicle Detector #1 is ON
(3)    OR Preempt Delay Timer > 5 seconds
(4)    OR Coord Plan is FREE
(5)    THEN Set Vehicle Detector #2 ON
        Delay 3 seconds
(6)    Set Phase 10 Green output OFF
        Delay 3 seconds
(8)    Set Phase 10 Green output ON
```

In this example, if the IF condition remains true for at least 3 seconds, phase 10 green output turns off; if the IF condition remains true for an additional 3 seconds, phase 10 green output turns on.

The order of executable elements and delay elements is *very* important. If the THEN statements are rearranged as shown below, vehicle detector #2 turns on and phase 10 green output turns off immediately; six seconds later, phase 10 green output turns on:

```
(5)      THEN Set Vehicle Detector #2 ON
(6)      Set Phase 10 Green output OFF
          Delay 3 seconds
          Delay 3 seconds
(8)      Set Phase 10 Green output ON
```

## Logic Flags

The *ASC/3* supports 64 user-settable logic flags. These logic flags are Boolean, i.e., they can have a value of true or false. The flags can be used as testable elements and can be set by executable elements. They can be used to link several testable elements together.

When the controller restarts, these flags are set to false. Otherwise, flags set to true remain true until explicitly set to false.

### Example:

#### Statement #1

```
IF ... (up to 10 testable elements)
THEN Set Logic Flag #1 ON
```

#### Statement #2

```
IF Logic Flag #1 is ON
AND ... (up to 9 more testable elements)
THEN Set Logic Flag #2 ON
```

#### Statement #3

```
IF Logic Flag #2 is ON
AND ... (up to 9 more testable elements)
THEN ...
```

This example uses two logic flags to link three logical elements together. A maximum of 28 testable elements can be linked together.

▪ Appendix L

The order of executable elements and setting of logic flags is *very* important. In this example, if Statements 2 and 3 are reversed:

**Statement #1**

```
IF ... (up to 10 testable elements)
THEN Set Logic Flag #1 ON
```

**Statement #3**

```
IF Logic Flag #2 is ON
AND ... (up to 9 more testable elements)
THEN ...
```

**Statement #2**

```
IF Logic Flag #1 is ON
AND ... (up to 9 more testable elements)
THEN Set Logic Flag #2 ON
```

Statement 3 does not get evaluated until the next tenth of a second because Logic Flag #2 does not get set until Statement 2 is processed.

## Testable Elements in the IF Condition

The following is a list of the *ASC/3* Logic Processor testable elements. Each entry describes the element, condition, and range of values to test against.

**Note** • The condition “!=” means “not equal”.

### Phase Testable Elements

Testable Element	Range	Operator	Condition	Description
CTR ON PH FORC OFF	0-16	IS	ON/OFF	The selected phase (1-16) or any (0) phase has FORCE OFF on. This state indicated when the selected phase (1-16) or any (0) green has been forced off. This testable element is true during the yellow Change and Red Clearance of the selected phase.
CTR ON PH PED CHK	0-16	IS	ON/OFF	The selected active phase (1-16) or any (0) phase pedestrian demand is ON or OFF.
CTR ON PHASE CALL	0-16	IS	ON/OFF	The selected phase (1-16) or any (0) phase check is ON or OFF if it is part of the active sequence. “CALL ON PHASE” does not indicate true if the phase is not part of the active sequence or omitted for any reason, This include an input, Coordinator, Preemptor, Time Base programming along with any other feature that omits the phase.
CTR ON PHASE CHECK	0-16	IS	ON/OFF	The selected phase (1-16) or any (0) phase demand (check) is ON or OFF.
CTR ON PHASE HOLD	0-16	IS	ON/OFF	The selected phase (1-16) or any (0) phase hold is ON or OFF.
CTR ON PHASE OMIT	0-16	IS	ON/OFF	The selected phase (1-16) or any (0) phase omit is ON or OFF.
CTR PED CALL ON PH	0-16	IS	ON/OFF	The selected active phase (1-16) or any (0) phase pedestrian check is ON or OFF. PED CALL ON PHASE does not indicate true if the phase pedestrian movement is not part of the active sequence or is omitted for any reason. This includes an input, Coordinator, Preemptor, Time Base programming along with any other feature that omits the phase pedestrian movement.
CTR PED OMIT ON PH	0-16	IS	ON/OFF	The selected phase (1-16) or any (0) phase pedestrian omit is ON or OFF.
CTR PH NEXT ON PHS	0-16	IS	ON/OFF	The selected phase (1-16) or any (0) phase next is ON or OFF.
CTR PHASE TIMING	0-16	IS	ON/OFF	The selected phase (1-16) or any (0) phase timing is ON or OFF.

▪ Appendix L

Testable Element	Range	Operator	Condition	Description
DET FAIL ON PHASE	0-16	IS	ON/OFF	The selected active phase (1-16) or any (0) phase failed detector is ON or OFF.
PED ON PH DONT WLK	0-16	IS	ON/OFF	The selected phase (1-16) or any (0) phase don't walk is ON or OFF.
PED ON PH PED CLR	0-16	IS	ON/OFF	The selected active phase (1-16) or any (0) phase pedestrian clearance is ON or OFF.
PED ON PH WALK	0-16	IS	ON/OFF	The selected active phase (1-16) or any (0) phase walk is ON or OFF.
VEH GREEN ON PH	0-16	IS	ON/OFF	The selected phase (1-16) or any (0) phase green is ON or OFF.
VEH RED ON PH	0-16	IS	ON/OFF	The selected phase (1-16) or any (0) phase red is ON or OFF.
VEH YELLOW ON PH	0-16	IS	ON/OFF	The selected phase (1-16) or any (0) phase yellow is ON or OFF.

*Ring Timer Testable Elements*

To determine when a timer is equal to a partial second, set a flag on the next higher value and delay the partial second required.

**Example:**

Determine when Minimum green for phase 1 (ring 1) has 1.2 seconds left. This will function only if stop time or manual advance is not applied during the delay period.

```

IF    MIN GREEN TME RING 1  IS  2
AND   GREEN ON PHASE 1      IS  ON (true for 1/10 second)
THEN  SET LOGIC FLAG 1      ON
IF    LOGIC FLAG 1          IS  ON
THEN  DELAY FOR 0.8
    
```

After the delay statement you can insert the elements that you want to become active when phase 1 minimum green has 1.2 seconds left.

---

**IMPORTANT** • Be sure to clear the logic flag when it is no longer required.

---

Testable Element	Range	Operator	Condition	Description
CTR MAX GRN TMR R $\beta$	$\beta = 1-4$	IS != > <	0-255	A phase in RING $\beta$ is timing Maximum Green down from the programmed value to zero in tenths of a second (.01 sec.). The value is entered in seconds. This value counts down. When in a phase is green with no conflicting demand, the Max Green Timer is set to zero.
CTR MAX OUT CNT PH	0-16	IS != > <	0-255	Test condition for the number of times continuous Max Out event happens on a specific phase.
CTR MIN GRN TMR R $\beta$	$\beta = 1-4$	IS != > <	0-255	A phase in RING $\beta$ is timing Minimum Green down from the programmed value to zero in tenths of a second (.01 sec.). The value is entered in seconds. This value counts down.
CTR PED CLR TMR R $\beta$	$\beta = 1-4$	IS != > <	0-255	A phase in RING $\beta$ is timing Pedestrian Clearance down from the programmed value to zero in tenths of a second (.01 sec.). The value is entered in seconds. This value counts down.
CTR PED WLK TMR R $\beta$	$\beta = 1-4$	IS != > <	0-255	A phase in RING $\beta$ is timing Walk down from the programmed value to zero in tenths of a second (.01 sec.). The value is entered in seconds. This value counts down.
CTR RED TIMER R $\beta$	$\beta = 1-4$	IS != > <	0-255	A phase in RING $\beta$ is timing Red Clearance down from the programmed value to zero in tenths of a second (.01 sec.). The value is entered in seconds. This value counts down.
VEH YELLOW TMR R $\beta$	$\beta = 1-4$	IS != > <	0-255	A phase in RING $\beta$ is timing Yellow Change down from the programmed value to zero in tenths of a second (.01 sec.). The value is entered in seconds. This value counts down.

Ring Input Testable Elements

Testable Element	Range	Operator	Condition	Description
CTR FORCE OFF RING	0-4	IS	ON/OFF	Force off input to the selected ring (1-4) or any ring (0) is ON or OFF.
CTR GAP OUT CNT PH	0-16	IS != > <	0-255	Test condition for the number of times continuous Gap Out event happens on a specific phase.
CTR INHBT MAX RING	0-4	IS	ON/OFF	Inhibit Maximum input to the selected ring (1-4) or any ring (0) is ON or OFF.
CTR MAX $\beta$ RING	$\beta = 0-4$	IS	ON/OFF	Max $\beta$ is input to the selected ring (1-4) or any ring (0) is ON or OFF.
CTR OMT RD CLR RNG	0-4	IS	ON/OFF	Omit Red Clearance input to the selected ring (1-4) or any ring (0) is ON or OFF.
CTR PED RECYC RING	0-4	IS	ON/OFF	Pedestrian recycle input to the selected ring (1-4) or any ring (0) is ON or OFF.
CTR RED REST RING	0-4	IS	ON/OFF	Red rest input to the selected ring (1-4) or any ring (0) is ON or OFF.
CTR STOP TIME RING	0-4	IS	ON/OFF	Stop Time input to the selected ring (1-4) or any ring (0) is ON or OFF.



## Overlap Testable Elements

Testable Element	Range	Operator	Condition	Description
CTR OL GRN EXT	0-16	IS	ON/OFF	Overlap A-P (1-16) or any overlap (0) is timing lag or trailing green.
CTR OL TRL RED CLR	0-16	IS	ON/OFF	Overlap A-P (1-16) or any overlap (0) is in red clearance.
CTR OVERLAP OMIT	0-16	IS	ON/OFF	Overlap A-P (1-16) or any overlap (0) omit is ON or OFF.
PED OL DON'T WALK	0-16	IS	ON/OFF	Overlap walk 1-16 or any overlap (0) Don't Walk is ON or OFF. An Overlap Don't Walk is a ped overlap enabled in MM-2-3 even if it is only one phase. The Ped Overlap must be comprised of at least one phase that has an enabled pedestrian movement. If it does not, the Don't Walk will not be sensed. The Ped Overlap Don't Walk will toggle at 1 PPS during the Pedestrian clearance.
PED OL PED CLEAR	0-16	IS	ON/OFF	Overlap walk 1-16 or any overlap (0) Ped Clearance is ON or OFF. An Overlap Ped Clearance is a ped overlap enabled in MM-2-3 even if it is only one phase.
PED OL WALK	0-16	IS	ON/OFF	Overlap walk 1-16 or any overlap (0) Walk is ON or OFF. An Overlap Walk is a ped overlap enabled in MM-2-3 even if it is only one phase.
VEH OVERLAP	0-16	IS	ON/OFF	Overlap A-P (1-16 respectively) or any overlap (0) is active.
VEH OVERLAP GREEN	0-16	IS	ON/OFF	Overlap A-P (1-16 respectively) or any overlap (0) is active.
VEH OVERLAP RED	0-16	IS	ON/OFF	Overlap A-P (1-16) or any overlap (0) is red. <b>NOTE:</b> OVERLAP RED 0 will be true unless all overlaps are either green or yellow. Any non-programmed overlap will be red.
VEH OVERLAP YLW	0-16	IS	ON/OFF	Overlap A-P (1-16) or any overlap (0) is timing lag or trailing green.

Coordinator Testable Elements

Testable Element	Range	Operator	Condition	Description
COORD CYCLE LENGTH		IS != > <	0-999	The cycle length in effect IS, !=, >, or < the programmed value even if the coordinator is free.
COORD CYCLE TIMER		IS != > <	0-2047	The coordinated cycle timer IS, !=, >, or < the programmed value in tenths of a second.
COORD FLASH		IS	ON/OFF	The coordinator is commanding flash (Pattern 255).
COORD FREE		IS	ON/OFF	The coordinator is commanding free (Pattern 254). If the TOD commanded free is required, set a Special Function output when that Action Plan is in effect and test for that output.
COORD IN STEP		IS	ON/OFF	The coordinator is commanded to a pattern even if the coordinator is free.
COORD MSTR CYC TMR		IS != > <	0-999	The master cycle timer IS, !=, >, or < the programmed value in seconds.
COORD OFFSET		IS != > <	0-255	The offset in effect IS, !=, >, or < the programmed value even if the coordinator is free.
COORD PLAN	1-63	IS != > <	0-120	The coordinated plan in effect IS, !=, >, or < the programmed value even if the coordinator is free.
COORD SPLT TMR RNG	0-4	IS != > <	0-2047	The split timer for ring (1-4) or any ring (0) IS (!=, >, or <) the programmed value in seconds. <b>Example:</b> To determine the split timing for a specific phase, use the following: IF PHASE TIMING 4 IS ON AND COORD SPLT TMR RNG 1 < 10 seconds

## Preemptor Testable Elements

Testable Element	Range	Operator	Condition	Description
PMT ADV TO EXIT		IS	ON/OFF	The preemption is preparing to exit. The PMT call is false. Minimum Dwell and Duration times are complete.
PMT ADV TO FLASH		IS	ON/OFF	The active preemptor is timing Track Clearance intervals yellow, all red and the preemptor will flash the dwell phases yellow and others red.
PMT ADV TRACK CLR		IS	ON/OFF	There is a preemptor timing entrance green, walk, pedestrian clearance, yellow or all red and there is a track clearance movement.
PMT ADVNCE TO HOLD		IS	ON/OFF	Indicated that the preemptor is starting to time the Cycling/Dwell phases.
PMT CYC DLY TMR		IS != > <	0-255	Check the EXTEND PREEMPT INPUT TIMER against the conditional setting.
PMT CYCLE DELAY		IS	ON/OFF	The Preemptor is timing the Extend Input time during Dwell/Cycling phases.
PMT CYCLING		IS	ON/OFF	The active preemptor is timing cycling phases.
PMT DELAY		IS	ON/OFF	There is a preemptor delay timing and there is no active preemptor.
PMT DELAY TIMER	0-10	IS != > <	0-2047	Time is entered in seconds for Preemptor 1-10 or any Preemptor "0" delay.
PMT DURATION TMR		IS != > <	0-255	The Duration Timer for the preemptor in effect is compared against the entered value and the element is set true when the selected conditions are true.
PMT DWELL		IS	ON/OFF	The active preemptor is timing dwell phases.
PMT FLASH		IS	ON/OFF	The Preemptor is being held during the Extend Input timing. This element is true when the Extend timer is timing and the preemption is in Dwell Flash.
PMT FLASH DELAY		IS	ON/OFF	The Preemptor is timing the Extend Input time during dwell flash.
PMT HOLD GREEN TMR		IS != > <	0-255	The Preemptor is being held during the Extend Input timing. This element measures the Extend timer.

▪ Appendix L

Testable Element	Range	Operator	Condition	Description
PMT INPUT	0-10	IS	ON/OFF	The selected preempt (1-10) or any preempt (0) input is active. This is regardless of the programming for that preemptor.
PMT MAX CALL TMR		IS != > <	0-255	The maximum time that a non-priority preemption call can be active and be recognized by the controller. Once failed, the input must return to inactive state to be recognized again.
PMT MIN DWELL TMR		IS != > <	0-255	The Dwell Timer for the preemptor in effect is compared against the entered value and the element is set true when the selected conditions are true.
PMT PREEMPT ACTIVE	0-10	IS	ON/OFF	The selected preempt (1-10) or any preempt (0) is active.
PMT RE-SERV TMR	0-10	IS != > <	0-2047	The Preemption Reservice time is tested against a particular value.
PMT TRACK CLEAR		IS	ON/OFF	The active preemptor is timing Track Clearance intervals green, yellow and all red.
PMT TRACK GRN TMR		IS != > <	0-255	The Track Clearance Green Timer for the preemptor in effect is compared against the entered value and the element is set true when the selected conditions are true.
PMT WAIT FOR PMT		IS	ON/OFF	There is no preemptor active and the controller will respond to the next preemption input. This feature is true during delay timing, all during preemption. It is not true when the controller is not in preemption or an input is inhibited because of Reservice timing.

## Detector Testable Elements

Testable Element	Range	Operator	Condition	Description
CTR PED ABSNC FAIL	0-16	IS	ON/OFF	The selected (1-16) or any (0) pedestrian detector has failed because of no activity. Refer to MM-6-7.
CTR PED ERRTC FAIL	0-16	IS	ON/OFF	The selected (1-16) pedestrian detector has failed because of excessive counts. Refer to MM-6-7.
CTR PED LOCK FAIL	0-16	IS	ON/OFF	The selected (1-16) or any (0) pedestrian detector has failed because of max presence. Refer to MM-6-7.
DET	1-64	IS	ON/OFF	The selected vehicle detector (1-64) is ON or OFF when the detector is assigned to a phase.
DET FAIL ON DET	1-64	IS	ON/OFF	The selected vehicle detector (1-64) failure is ON or OFF when the detector is assigned to a phase. When not assigned to a phase. The detector does not fail.
DET OCCUPANCY %	1-64	IS != > <	0-999	The selected (1-64) vehicle detector occupancy in 0.5% increments for an enabled detector (MM-6-2) that was collected during the last NTCIP Log Period (MM-6-4). 0-200 = 0 to 100% in 0.5% increments. Enter the occupancy level that is being tested multiplied by 2 (for example, 0 = 0%, 36 = 18%, 63 = 31.5%). 210 = Max Presence Fault 211 = No Activity Fault 212 = Open Loop Fault 213 = Shorted Loop Fault 214 = Excessive Change Fault 216 = Watchdog Fault 217 = Erratic count Fault <b>NOTE:</b> When there is more than one fault active, the highest number is reported.
DET PED	0-16	IS	ON/OFF	The selected (1-16) or any (0) pedestrian detector is on or off ON or OFF when the detector is assigned to a phase and that phase has a ped movement programmed.
DET TMR DELAY	1-64	IS	ON/OFF	The selected vehicle detector (1-64) is timing delay when the detector is assigned to a phase. When not assigned to a phase. The detector delay does not time.
DET TMR EXTND	1-64	IS	ON/OFF	The selected vehicle detector (1-64) is extension is timing when the detector is assigned to a phase. When not assigned to a phase. The detector extension does not time.
DET VOLUME	1-64	IS != > <	0-2047	The selected (1-64) vehicle detector volume count for an enabled detector (MM-6-2) that was collected during the last NTCIP Log Period (MM-6-4). 0-254 = The volume data collected. 255 = The volume of the data collected is greater than 254.

*Time-of-Day (TOD) Testable Elements*

Testable Element	Operator	Condition	Description
TOD DAY OF WEEK	IS != > <	1-7	Determines if the TOD Day of Week is equal to, not equal to, greater than or less than the compared-to value. Sunday is day 1 for this comparison.
TOD DOM	IS != > <	1-31	Determines if the TOD Day of Month is equal to, not equal to, greater than or less than the compared to value.
TOD HOUR	IS != > <	0-23	Determines if the TOD Hour is equal to, not equal to, greater than or less than the compared-to value. Sunday is day 1 for this comparison.
TOD MINUTE	IS != > <	0-59	Determines if the TOD Day of Week is equal to, not equal to, greater than or less than the compared to value. Sunday is day 1 for this comparison.
TOD MONTH	IS != > <	1-12	Determines if the TOD Month is equal to, not equal to, greater than or less than the compared-to value.
TOD SECOND	IS != > <	0-59	Determines if the TOD Day of Week is equal to, not equal to, greater than or less than the compared-to value. Sunday is day 1 for this comparison.
TOD TENTH SEC	IS != > <	0-9	Determines if the TOD Day of Week is equal to, not equal to, greater than or less than the compared-to value. Sunday is day 1 for this comparison.

### Logic Processor (LP) Testable Elements

Testable Element	Range	Operator	Condition	Description
LP FLAG	1-64	IS	ON/OFF	Determines if a logic flag is ON (set) or OFF (reset). The logic flags are not automatically reset except at power ON. When used, an LP element, when no longer required, must reset them.
LP STATEMENT	1-64	IS	ON/OFF	Determines if a logic statement is enabled from any source. These sources are enabled manually (MM-1-8-1) and, if allowed, by the action plan in effect (MM-5-4).

### CIB & COB Testable Elements

**Note** • CIB = Controller Input Buffer; COB = Controller Output Buffer.

Testable Element	Range	Description
LP CIB CODE OFF	0-575	Checks if the state of the selected CIB bit number (0-575) is OFF.
LP CIB CODE ON	0-575	Checks if the state of the selected CIB bit number (0-575) is ON.
LP COB CODE OFF	0-767	Checks if the state of the selected COB bit number (0-767) is OFF.
LP COB CODE ON	0-767	Checks if the state of the selected CIB bit number (0-767) is ON.

### Miscellaneous Testable Elements

Testable Element	Range	Operator	Condition	Description
COORD SPLIT PATTERN		IS	1-120	Checks if split pattern (1-120) is in effect.
CTR BIKE GRN ON PH	1-16	IS	ON/OFF	Checks if bike Green timing on phase (1-16) is ON or OFF.
CTR PH RECALL PLAN		IS	1-4	Checks if phase recall plan (1-4) is in effect.
CTR SEQUENCE #		IS	1-20	Checks if controller is running a particular sequence number.
CTR TM PLN N EFFCT		IS	1-4	Checks if timing plan (1-4) is in effect.
DET BIKE CALL PH	1-16	IS	ON/OFF	Checks if bike call on phase (1-16) is ON or OFF.
DET PLAN NUM		IS	1-4	Checks if detector plan (1-4) is in effect.
TOD ACTION PLAN #		IS	1-100	Checks if action plan (1-100) is in effect.
TOD DAY PLAN #		IS	1-4	Checks if day plan (1-4) is in effect.

## Executable Elements in THEN/ELSE

The following is a list of the *ASC/3* Logic Processor Executable Elements. Each entry describes the element, range of values, and individual SET action.

### Phase Output Executable Elements

Executable Element	Range	Action	Description
SIG SET PH D WALK	0-16	ON/OFF	Sets the phase don't walk output ON or OFF. The state of the green output will return to the phase state every tenth of a second. To keep the output ON or OFF, the logic processor must turn it ON or OFF every tenth of a second.
SIG SET PH GREEN	0-16	ON/OFF	Sets the phase green output ON or OFF. The state of the green output will return to the phase state every tenth of a second. To keep the output ON or OFF, the logic processor must turn it ON or OFF every tenth of a second.
SIG SET PH PED CLR	0-16	ON/OFF	Sets the phase pedestrian clearance output ON or OFF. The state of the green output will return to the phase state every tenth of a second. To keep the output ON or OFF, the logic processor must turn it ON or OFF every tenth of a second.
SIG SET PH YELLOW	0-16	ON/OFF	Sets the phase yellow output ON or OFF. The state of the green output will return to the phase state every tenth of a second. To keep the output ON or OFF, the logic processor must turn it ON or OFF every tenth of a second.
SIG SET PHASE RED	0-16	ON/OFF	Sets the phase red output ON or OFF. The state of the green output will return to the phase state every tenth of a second. To keep the output ON or OFF, the logic processor must turn it ON or OFF every tenth of a second.
SIG SET PHASE WALK	0-16	ON/OFF	Sets the phase walk output ON or OFF. The state of the green output will return to the phase state every tenth of a second. To keep the output ON or OFF, the logic processor must turn it ON or OFF every tenth of a second.

### Overlap Output Executable Elements

Executable Element	Range	Action	Description
SIG SET OLP RED	0-16	ON/OFF	Sets the overlap red output ON or OFF. The state of the green output will return to the phase state every tenth of a second. To keep the output ON or OFF, the logic processor must turn it ON or OFF every tenth of a second.
SIG SET OLP YELLOW	0-16	ON/OFF	Sets the overlap yellow output ON or OFF. The state of the green output will return to the phase state every tenth of a second. To keep the output ON or OFF, the logic processor must turn it ON or OFF every tenth of a second.
SIG SET OVLP GREEN	0-16	ON/OFF	Sets the overlap green output ON or OFF. The state of the green output will return to the phase state every tenth of a second. To keep the output ON or OFF, the logic processor must turn it ON or OFF every tenth of a second.



*Detector Input Executable Elements*

Executable Element	Range	Action	Description
DET SET PED	1-8	ON/OFF	Sets the “raw” pedestrian detector. If attempting to interrupt a pedestrian call and redirect it, use the SET COB ON 64-79 ON/OFF executable element.
DET SET PED2	1-16	ON/OFF	Sets the “raw” pedestrian detector 2.
DET SET VEH 1-16	1-16	ON/OFF	Sets the “raw” vehicle detector 1-16 ON or OFF.
DET SET VEH 17-32	17-32	ON/OFF	Sets the “raw” vehicle detector 17-32 ON or OFF.
DET SET VEH 33-48	33-48	ON/OFF	Sets the “raw” vehicle detector 33-48 ON or OFF.
DET SET VEH 49-64	49-64	ON/OFF	Sets the “raw” vehicle detector 49-64 ON or OFF.
DET SET VH PLN A-C	1-4	ON	Sets the specified vehicle plan ON.

*Ring Input Executable Elements*

Executable Element	Range	Action	Description
CTR OMIT RD CLR RG	0-4	ON/OFF	Turns OMIT RED CLEARANCE input ON or OFF to a selected ring (1-4) or all rings (0).
CTR SET FO RING	0-4	ON/OFF	Turns FORCE OFF input ON or OFF to a selected ring (1-4) or all rings (0).
CTR SET INH MAX RG	0-4	ON/OFF	Turns INHIBIT MAX input ON or OFF to a selected ring (1-4) or all rings (0).
CTR SET MAX2 RING	0-4	ON/OFF	Turns MAX 2 input ON or OFF to a selected ring (1-4) or all rings (0).
CTR SET MAX3 RING	0-4	ON/OFF	Turns MAX 3 input ON or OFF to a selected ring (1-4) or all rings (0).
CTR SET PED REC RG	0-4	ON/OFF	Turns PEDESTRIAN RECYCLE input ON or OFF to a selected ring (1-4) or all rings (0).
CTR SET RD REST RG	0-4	ON/OFF	Turns RED REST input ON or OFF to a selected ring (1-4) or all rings (0).
CTR SET STIME RING	0-4	ON/OFF	Turns STOP TIME input ON or OFF to a selected ring (1-4) or all rings (0).

Unit Input Executable Elements

Executable Element	Range	Action	Description																																																																																					
CRD SET FREE		ON/OFF	Turns COORDINATION FREE input ON or OFF.																																																																																					
CRD SET OSET B 1-3	0-3	ON/OFF	Turns OFFSET BIT INPUTS input ON or OFF for a selected offset bit input (1-3) or all inputs (0).																																																																																					
CRD SET SPL DEMND1		ON/OFF	Turns SPLIT DEMAND 1 input ON or OFF.																																																																																					
CRD SET SPL DEMND2		ON/OFF	Turns SPLIT DEMAND 2 input ON or OFF.																																																																																					
CRD SET SPLT B 1-2	0-2	ON/OFF	Turns SPLIT BIT INPUTS input ON or OFF for a selected split bit input (1-2) or all inputs (0).																																																																																					
CRD SET SYNC		ON/OFF	Turns COORDINATION SYNC input ON or OFF.																																																																																					
CRD ST CYC BIT 1-3	0-3	ON/OFF	Turns CYCLE BIT inputs input ON or OFF for a selected cycle bit input (1-3) or all inputs (0).																																																																																					
CRD ST DUAL COORD		ON/OFF	Turns DUAL COORDINATION input ON or OFF.																																																																																					
CTR SET ALARM	0-16	ON/OFF	Turns input for selected alarms (1-16) or all alarms (0) ON or OFF.																																																																																					
CTR SET AT SEQ A-D	0-4	ON/OFF	Turns selected (1-4) or all (0) ALTERNATE SEQUENCE inputs ON or OFF. Use SET CIB CODE ON/OFF for locations 416-420 respectively for A-D. Sequence 0-15 is a BCD representation of A-D, where D is highest. These inputs must be enabled in MM-1-1-1.  <table border="0" style="margin-left: 40px;"> <tr> <td style="text-align: right;"><b>Seq</b></td> <td><b>ALT</b></td> <td><b>CALT</b></td> <td><b>BALT</b></td> <td><b>A</b></td> </tr> <tr> <td>1</td> <td>OFF</td> <td>OFF</td> <td>ON</td> <td></td> </tr> <tr> <td>2</td> <td>OFF</td> <td>ON</td> <td>OFF</td> <td></td> </tr> <tr> <td>3</td> <td>OFF</td> <td>ON</td> <td>ON</td> <td></td> </tr> <tr> <td>4</td> <td>ON</td> <td>OFF</td> <td>OFF</td> <td></td> </tr> <tr> <td>5</td> <td>ON</td> <td>OFF</td> <td>ON</td> <td></td> </tr> <tr> <td>6</td> <td>ON</td> <td>ON</td> <td>OFF</td> <td></td> </tr> <tr> <td>7</td> <td>ON</td> <td>ON</td> <td>ON</td> <td></td> </tr> <tr> <td>8</td> <td>OFF</td> <td>OFF</td> <td>OFF</td> <td></td> </tr> <tr> <td>9</td> <td>OFF</td> <td>OFF</td> <td>ON</td> <td></td> </tr> <tr> <td>10</td> <td>OFF</td> <td>ON</td> <td>OFF</td> <td></td> </tr> <tr> <td>11</td> <td>OFF</td> <td>ON</td> <td>ON</td> <td></td> </tr> <tr> <td>12</td> <td>ON</td> <td>OFF</td> <td>OFF</td> <td></td> </tr> <tr> <td>13</td> <td>ON</td> <td>OFF</td> <td>ON</td> <td></td> </tr> <tr> <td>14</td> <td>ON</td> <td>ON</td> <td>OFF</td> <td></td> </tr> <tr> <td>15</td> <td>ON</td> <td>ON</td> <td>ON</td> <td></td> </tr> <tr> <td>16</td> <td>OFF</td> <td>OFF</td> <td>OFF</td> <td></td> </tr> </table>	<b>Seq</b>	<b>ALT</b>	<b>CALT</b>	<b>BALT</b>	<b>A</b>	1	OFF	OFF	ON		2	OFF	ON	OFF		3	OFF	ON	ON		4	ON	OFF	OFF		5	ON	OFF	ON		6	ON	ON	OFF		7	ON	ON	ON		8	OFF	OFF	OFF		9	OFF	OFF	ON		10	OFF	ON	OFF		11	OFF	ON	ON		12	ON	OFF	OFF		13	ON	OFF	ON		14	ON	ON	OFF		15	ON	ON	ON		16	OFF	OFF	OFF	
<b>Seq</b>	<b>ALT</b>	<b>CALT</b>	<b>BALT</b>	<b>A</b>																																																																																				
1	OFF	OFF	ON																																																																																					
2	OFF	ON	OFF																																																																																					
3	OFF	ON	ON																																																																																					
4	ON	OFF	OFF																																																																																					
5	ON	OFF	ON																																																																																					
6	ON	ON	OFF																																																																																					
7	ON	ON	ON																																																																																					
8	OFF	OFF	OFF																																																																																					
9	OFF	OFF	ON																																																																																					
10	OFF	ON	OFF																																																																																					
11	OFF	ON	ON																																																																																					
12	ON	OFF	OFF																																																																																					
13	ON	OFF	ON																																																																																					
14	ON	ON	OFF																																																																																					
15	ON	ON	ON																																																																																					
16	OFF	OFF	OFF																																																																																					
CTR SET AUTO FLASH		ON/OFF	Turns AUTO FLASH input ON or OFF.																																																																																					
CTR SET CNA 1		ON/OFF	Turns CAN 1 (call to non-actuated) input ON or OFF.																																																																																					
CTR SET CNA 2		ON/OFF	Turns CAN 2 (call to non-actuated) input ON or OFF.																																																																																					

Executable Element	Range	Action	Description
CTR SET DB CRC	0-16	ON/OFF	Turns selected (1-16) or all (0) DATA BASE CRC (Circular Redundant Check) inputs ON or OFF.
CTR SET DIMMING EN		ON/OFF	Turns DIMMING ENABLE input ON or OFF.
CTR SET DIS PRETM		ON/OFF	Turns DISABLE PRE-TIMED OPERATION input ON or OFF.
CTR SET EXT START		ON/OFF	Turns EXTERNAL START input ON or OFF.
CTR SET INT ADV		ON/OFF	Turns INTERVAL ADVANCE input ON or OFF.
CTR SET LMP CTRL		ON/OFF	Turns INDICATOR LAMP input ON or OFF.
CTR SET LOCAL FL		ON/OFF	Turns LOCAL FLASH input ON or OFF.
CTR SET MAINT REQD		ON/OFF	Turns MAINTENANCE REQUIRED (door open) input ON or OFF.
CTR SET MAN CTR EN		ON/OFF	Turns MANUAL CONTROL ENABLE input ON or OFF.
CTR SET MIN RECALL		ON/OFF	Turns MINIMUM RECALL input ON or OFF.
CTR SET MMU FLASH		ON/OFF	Turns MMU FLASH input ON or OFF.
CTR SET MMU STIME		ON/OFF	Turns MMU STOP TIME input ON or OFF.
CTR SET PH NEXT RX		ON/OFF	Turns PHASE NEXT DECISION MADE IN RED TRANSFER input ON or OFF.
CTR SET STIME ALL		ON/OFF	Turns STOP TIME ALL RINGS input ON or OFF.
CTR SET TEST A-E	1-5	ON/OFF	1, 2, 3, 4, 5 correspond to input pins Test A, Test B, Test C, Test D, and Test E, respectively.
CTR SET TMGPLN A-C	0-3	ON/OFF	Turns selected bits (1-3) or none (0) TIMING PLAN BIT inputs ON or OFF. Timing Plan 1 = 100, Plan 2 = 010, Plan 3 = 110, and Plan 4 = 001 Bits A-C, respectively. Any other combination of Bits A, B, C result in the Timing Plan called by the Time Base.
CTR SET WK RST MOD		ON/OFF	Turns WALK REST MODIFIER input ON or OFF.
DET SET PEDDIA A-C	0-3	ON/OFF	Turns selected (1-3) PEDESTRIAN DIAGNOSTIC PLAN inputs ON or OFF.
DET SET VH DIA A-C	0-3	ON/OFF	Turns selected (1-3) VEHICLE DIAGNOSTIC PLAN inputs ON or OFF.
IM SET PWR SENSE		ON/OFF	Turns INTERSECTION MONITOR POWER SENSE input ON or OFF.
OL OMIT OVLP A-P	0-16	ON/OFF	Turns selected (1-16) or all (0) OVERLAP OMIT inputs ON or OFF.
PMT CALL L PRI PMT	0-10	ON/OFF	Turns selected (1-10) or all (0) CALL LOW PRIORITY PREEMPTION inputs ON or OFF.
PMT CALL PMT SEQ	0-10	ON/OFF	Turns input for selected (1-10) or all (0) preemptors ON or OFF.
PMT SET INTERLOCK	0-10	ON/OFF	Turns selected (1-10) or all (0) PREEMPTION INTERLOCK inputs ON or OFF.

▪ Appendix L

Executable Element	Range	Action	Description
PMT SET KBD LOCK	0-10	ON/OFF	Turns input from the keyboard for selected (1-10) or all (0) preemptors ON or OFF.
SET VEH PLAN A-C	0-3	ON/OFF	Turns selected (1-3) or all (0) VEHICLE DETECTION PLAN inputs ON or OFF.
SIG TERM OVLP A-P	0-16	ON/OFF	Turns selected (1-16) or all (0) TERMINATE OVERLAP NOW inputs ON or OFF. To keep the overlap off, apply "OL OMIT OVLP A-P" at the same time.
TLM S ADDR BIT 0-4	0-4	ON/OFF	Turns ADDRESS BIT inputs input ON or OFF for a selected address bit input (1-4) or all inputs (0).
TLM SET EXT ADDR		ON/OFF	Turns TELEMETRY EXTERNAL ADDRESS ENABLE input ON or OFF.
TLM SET SPARE 1		ON/OFF	Turns TELEMETRY SPARE 1 input ON or OFF.
TLM SET SPARE 2		ON/OFF	Turns TELEMETRY SPARE 2 input ON or OFF.
TOD SET TBC ON LNE		ON/OFF	Turns TIME BASE CONTROL input ON or OFF.
TOD SET TIME RESET		ON/OFF	Turns EXTERNAL TIME REST input ON or OFF.
TSP SET CHKIN DET	0-6	ON/OFF	Turns selected (1-6) or all (0) TRANSIT SIGNAL PRIORITY CHECK-IN inputs ON or OFF.
TSP SET CHKOUT DET	0-6	ON/OFF	Turns selected (1-6) or all (0) TRANSIT SIGNAL PRIORITY CHECK-OUT inputs ON or OFF.

*Phase Input Executable Elements*

Executable Element	Range	Action	Description
CTR CALL PED PHASE	0-16	ON/OFF	Turns selected (1-16) or all (0) PHASE PEDESTRIAN CALL inputs ON or OFF.
CTR CALL PHASE	0-16	ON/OFF	Turns selected (1-16) or all (0) PHASE VEHICLE CALL inputs ON or OFF.
CTR HOLD PHASE	0-16	ON/OFF	Turns HOLD input ON or OFF to a selected phase (1-16) or all phases (0).
CTR OMIT PED PHASE	0-16	ON/OFF	Turns PED OMIT input ON or OFF to a selected phase (1-16) or all phases (0).
CTR OMIT PHASE	0-16	ON/OFF	Turns OMIT input ON or OFF to a selected phase (1-16) or all phases (0).
CTR SET PED EXT PH	0-16	ON/OFF	Turns selected (1-16) or all (0) PEDESTRIAN EXTEND DETECTOR inputs ON or OFF.
CTR SET RED EXT PH	0-16	ON/OFF	Turns selected (1-16) or all (0) RED EXTEND inputs ON or OFF.
DET CALL BIKE PH	0-16	ON/OFF	Turns selected (1-16) or all (0) PHASE BICYCLE CALL inputs ON or OFF.
DET CALL PED2 PH	0-16	ON/OFF	Turns selected (1-16) or all (0) PHASE PEDESTRIAN 2 inputs ON or OFF.

*Logic Processor (LP) Executable Elements*

Executable Element	Range	Action	Description
LP DELAY FOR	0.0 - 204.7 seconds		Delay for the entered time before the following elements will be executed.
LP SET CIB OFF	0-575		Sets the selected CIB bit number (0-575) OFF.
LP SET CIB ON	0-575		Sets the selected CIB bit number (0-575) ON.
LP SET COB OFF	0-767		Sets the selected COB bit number (0-767) OFF.
LP SET COB ON	0-767		Sets the selected COB bit number (0-767) ON.
LP SET LOGIC FLAG	0-63	ON/OFF	Sets LOGIC flag ON or OFF. Once set, the Logic Flag will remain ON until turned OFF.
LP SET LP GROUP	0-10		Sets the specified Logic Processor Group ON.

*Miscellaneous Executable Elements*

Executable Element	Range	Action	Description
CTR S EXT STRT DIS		ON/OFF	If this is programmed, Ignore External Start Input for 20 minutes. The preferred method is to use MM-1-4-2, MMU TO CU SDLC EXTERNAL START option.
TOD SET ACT PLN ON	1-100		Activate the programmed Action Plan.
TOD SET TMG PLN ON	1-4		Activate the programmed Timing Plan.

---

**For your notes:**



---

# Hardware Diagnostic Cables

## General Information

When performing the Auto-Loop diagnostic test which automatically cycles through all of the individual diagnostic tests in sequence, the *ASC/3* controller power should be disconnected and all loopback cables should be installed before the Auto-Loop test is started. When performing individual tests that require a loopback cables, power should be disconnected before the any loopback cable is installed.

The tables that follow describe the configuration of each of the individual *ASC/3* controller loopback cables.

**33279G1 – ASC-2100 A Connector Loop Back Cable**

Wire No.	Prep Item	Length (inches)	From Item	From Term	From Fit	To Item	To Term	To Fit	Remarks
1	1	8	PA	f	C	PA	s	C	26 WHT
2	1	8	PA	g	C	PA	Z	C	26 WHT
3	1	8	PA	h	C	PA	D	C	26 WHT
4	1	8	PA	N	C	PA	t	C	26 WHT
5	1	8	PA	EE	C	PA	a	C	26 WHT
6	1	8	PA	FF	C	PA	E	C	26 WHT
7	1	8	PA	w	C	PA	DD	C	26 WHT
8	1	8	PA	P	C	PA	u	C	26 WHT
9	1	8	PA	T	C	PA	CC	C	26 WHT-W/NEXT WIRE
10	1	8	PA	CC	C	PA	R	C	26 WHT-W/NEXT WIRE
11	1	8	PA	R	C	PA	AA	C	26 WHT
12	1	8	PA	S	C	PA	r	C	26 WHT-W/NEXT WIRE
13	1	8	PA	r	C	PA	k	C	26 WHT
14	1	8	PA	BB	C	PA	Y	C	26 WHT-W/NEXT WIRE
15	1	8	PA	Y	C	PA	j	C	26 WHT
16	1	8	PA	m	C	PA	X	C	26 WHT-W/NEXT WIRE
17	1	8	PA	X	C	PA	z	C	26 WHT
18	1	8	PA	K	C	PA	c	C	26 WHT
19	1	8	PA	L	C	PA	b	C	26 WHT
20	1	8	PA	M	C	PA	F	C	26 WHT
21	1	8	PA	n	C	PA	J	C	26 WHT
22	1	8	PA	v	C	PA	H	C	26 WHT
23	1	8	PA	i	C	PA	G	C	26 WHT
24	1	8	PA	x	C	PA	e	C	26 WHT
25	1	8	PA	GG	C	PA	d	C	26 WHT
26	1	8	PA	A	C	PA	q	C	26 WHT
27	1	8	PA	C	C	PA	HH	C	26 WHT-W/NEXT WIRE
28	1	8	PA	HH	C	PA	y	C	26 WHT
29	2	6	PWR	AC+	S	PA	p	C	20 BLK SPLICE W/PWR CORD BLK
30	3	6	PWR	AC-	S	PA	U	C	20 WHT SPLICE W/PWR CORD WHT
31	4	6	PWR	GND	S	PA	V	C	20 GRN SPLICE W/PWR CORD GRN



## 33279G2 – ASC-2100 B Connector Loop Back Cable

From Item	From Term	From Fit	To Item	To Term	To Fit	Remarks
PB	N	C	PB	D	C	W/NEXT WIRE
PB	D	C	PB	AA	C	
PB	P	C	PB	E	C	W/NEXT WIRE
PB	E	C	PB	p	C	
PB	i	C	PB	F	C	W/NEXT WIRE
PB	F	C	PB	q	C	
PB	R	C	PB	Y	C	W/NEXT WIRE
PB	Y	C	PB	FF	C	
PB	m	C	PB	Z	C	W/NEXT WIRE
PB	Z	C	PB	HH	C	W/NEXT WIRE
PB	HH	C	PB	T	C	W/NEXT WIRE
PB	T	C	PB	a	C	W/NEXT WIRE
PB	a	C	PB	DD	C	
PB	j	C	PB	s	C	W/NEXT WIRE
PB	s	C	PB	A	C	
PB	U	C	PB	r	C	
PB	V	C	PB	t	C	
PB	L	C	PB	b	C	W/NEXT WIRE
PB	b	C	PB	GG	C	
PB	M	C	PB	c	C	W/NEXT WIRE
PB	c	C	PB	BB	C	
PB	h	C	PB	G	C	W/NEXT WIRE
PB	G	C	PB	CC	C	
PB	g	C	PB	d	C	W/NEXT WIRE
PB	d	C	PB	w	C	
PB	n	C	PB	H	C	W/NEXT WIRE
PB	H	C	PB	EE	C	W/NEXT WIRE
PB	EE	C	PB	k	C	W/NEXT WIRE
PB	k	C	PB	J	C	W/NEXT WIRE
PB	J	C	PB	u	C	
PB	x	C	PB	e	C	W/NEXT WIRE
PB	e	C	PB	C	C	
PB	S	C	PB	K	C	
PB	z	C	PB	f	C	W/NEXT WIRE
PB	f	C	PB	B	C	W/NEXT WIRE
PB	B	C	PB	W	C	W/NEXT WIRE
PB	W	C	PB	X	C	W/NEXT WIRE
PB	X	C	PB	v	C	W/NEXT WIRE
PB	v	C	PB	y	C	

**33279G3 – ASC-2100 C Connector Loop Back Cable**

Wire No.	Description of Wire	Length (inches)	From Item	From Term	From Fit	To Item	To Term	To Fit	Remarks
1	26 AWG WHT	8	PC	P	C	PC	i	C	W/NEXT WIRE
2	26 AWG WHT	8	PC	i	C	PC	K	C	W/NEXT WIRE
3	26 AWG WHT	8	PC	K	C	PC	M	C	
4	26 AWG WHT	8	PC	R	C	PC	J	C	W/NEXT WIRE
5	26 AWG WHT	8	PC	J	C	PC	L	C	W/NEXT WIRE
6	26 AWG WHT	8	PC	L	C	PC	DD	C	
7	26 AWG WHT	8	PC	m	C	PC	H	C	W/NEXT WIRE
8	26 AWG WHT	8	PC	H	C	PC	N	C	
9	26 AWG WHT	8	PC	n	C	PC	j	C	W/NEXT WIRE
10	26 AWG WHT	8	PC	j	C	PC	k	C	
11	26 AWG WHT	8	PC	a	C	PC	PP	C	
12	26 AWG WHT	8	PC	u	C	PC	HH	C	
13	26 AWG WHT	8	PC	v	C	PC	A	C	
14	26 AWG WHT	8	PC	Z	C	PC	B	C	
15	26 AWG WHT	8	PC	Y	C	PC	c	C	
16	26 AWG WHT	8	PC	S	C	PC	g	C	W/NEXT WIRE
17	26 AWG WHT	8	PC	g	C	PC	AA	C	
18	26 AWG WHT	8	PC	T	C	PC	h	C	W/NEXT WIRE
19	26 AWG WHT	8	PC	h	C	PC	z	C	
20	26 AWG WHT	8	PC	p	C	PC	G	C	W/NEXT WIRE
21	26 AWG WHT	8	PC	G	C	PC	CC	C	
22	26 AWG WHT	8	PC	q	C	PC	LL	C	W/NEXT WIRE
23	26 AWG WHT	8	PC	LL	C	PC	BB	C	
24	26 AWG WHT	8	PC	V	C	PC	f	C	W/NEXT WIRE
25	26 AWG WHT	8	PC	f	C	PC	KK	C	
26	26 AWG WHT	8	PC	U	C	PC	E	C	W/NEXT WIRE
27	26 AWG WHT	8	PC	E	C	PC	y	C	
28	26 AWG WHT	8	PC	EE	C	PC	F	C	W/NEXT WIRE
29	26 AWG WHT	8	PC	F	C	PC	NN	C	
30	26 AWG WHT	8	PC	r	C	PC	JJ	C	W/NEXT WIRE
31	26 AWG WHT	8	PC	JJ	C	PC	MM	C	
32	26 AWG WHT	8	PC	t	C	PC	x	C	W/NEXT WIRE
33	26 AWG WHT	8	PC	x	C	PC	w	C	
34	26 AWG WHT	8	PC	W	C	PC	e	C	W/NEXT WIRE
35	26 AWG WHT	8	PC	e	C	PC	C	C	
36	26 AWG WHT	8	PC	X	C	PC	D	C	W/NEXT WIRE
37	26 AWG WHT	8	PC	D	C	PC	GG	C	
38	26 AWG WHT	8	PC	s	C	PC	d	C	W/NEXT WIRE
39	26 AWG WHT	8	PC	d	C	PC	FF	C	W/NEXT WIRE
40	26 AWG WHT	8	PC	FF	C	PC	b	C	

## 33279G4 – ASC-2100 D Connector Loop Back Cable

Wire No.	Description of Wire	Length (inches)	From Item	From Term	From Fit	To Item	To Term	To Fit	Remarks
1	26 AWG WHT	8	D	1	C	D	57	C	
2	26 AWG WHT	8	D	2	C	D	50	C	
3	26 AWG WHT	8	D	5	C	D	60	C	W/NEXT WIRE
4	26 AWG WHT	8	D	60	C	D	49	C	
5	26 AWG WHT	8	D	8	C	D	61	C	
6	26 AWG WHT	8	D	11	C	D	55	C	
7	26 AWG WHT	8	D	15	C	D	56	C	
8	26 AWG WHT	8	D	21	C	D	58	C	
9	26 AWG WHT	8	D	22	C	D	9	C	
10	26 AWG WHT	8	D	23	C	D	38	C	
11	26 AWG WHT	8	D	24	C	D	3	C	
12	26 AWG WHT	8	D	27	C	D	12	C	
13	26 AWG WHT	8	D	28	C	D	36	C	
14	26 AWG WHT	8	D	29	C	D	10	C	
15	26 AWG WHT	8	D	32	C	D	6	C	
16	26 AWG WHT	8	D	33	C	D	4	C	
17	26 AWG WHT	8	D	34	C	D	47	C	
18	26 AWG WHT	8	D	41	C	D	20	C	
19	26 AWG WHT	8	D	42	C	D	13	C	
20	26 AWG WHT	8	D	43	C	D	16	C	
21	26 AWG WHT	8	D	44	C	D	14	C	
22	26 AWG WHT	8	D	45	C	D	19	C	
23	26 AWG WHT	8	D	46	C	D	18	C	
24	26 AWG WHT	8	D	48	C	D	17	C	
25	26 AWG WHT	8	D	51	C	D	25	C	
26	26 AWG WHT	8	D	52	C	D	30	C	
27	26 AWG WHT	8	D	53	C	D	26	C	W/NEXT WIRE
28	26 AWG WHT	8	D	26	C	D	40	C	
29	26 AWG WHT	8	D	54	C	D	31	C	W/NEXT WIRE
30	26 AWG WHT	8	D	31	C	D	35	C	
31	26 AWG WHT	8	D	59	C	D	37	C	W/NEXT WIRE
32	26 AWG WHT	8	D	37	C	D	39	C	

## 33279G5 – 25-Pin FSK Loop Back Diagnostic Cable

Wire No.	Description of Wire	Length (inches)	From Item	From Term	From Fit	To Item	To Term	To Fit	Remarks
1	26 AWG WHT	8	P3	9	C	P3	3	C	W/NEXT WIRE
2	26 AWG WHT	8	P3	3	C	P3	4	C	W/NEXT WIRE
3	26 AWG WHT	8	P3	4	C	P3	14	C	W/NEXT WIRE
4	26 AWG WHT	8	P3	14	C	P3	15	C	
5	26 AWG WHT	8	P3	22	C	P3	2	C	W/NEXT WIRE
6	26 AWG WHT	8	P3	2	C	P3	1	C	W/NEXT WIRE
7	26 AWG WHT	8	P3	1	C	P3	17	C	W/NEXT WIRE
8	26 AWG WHT	8	P3	17	C	P3	20	C	
9	26 AWG WHT	8	P3	10	C	P3	5	C	W/NEXT WIRE
10	26 AWG WHT	8	P3	5	C	P3	7	C	W/NEXT WIRE
11	26 AWG WHT	8	P3	7	C	P3	21	C	W/NEXT WIRE
12	26 AWG WHT	8	P3	21	C	P3	18	C	
13	26 AWG WHT	8	P3	23	C	P3	19	C	W/NEXT WIRE
14	26 AWG WHT	8	P3	19	C	P3	8	C	W/NEXT WIRE
15	26 AWG WHT	8	P3	8	C	P3	6	C	W/NEXT WIRE
16	26 AWG WHT	8	P3	6	C	P3	16	C	
17			R1	1	S	R3	1	S	INSTALL ASSY IN CONN
18			R1	2	S	R4	1	S	INSTALL ASSY IN CONN
19			R2	1	S	R3	2	S	INSTALL ASSY IN CONN
20			R2	2	S	R4	2	S	INSTALL ASSY IN CONN
21	26 AWG WHT	8	R3	2	S	P3	12	C	TRANSMIT 1
22	26 AWG WHT	8	R4	2	S	P3	13	C	TRANSMIT 2
23	26 AWG WHT	8	R3	1	S	P3	24	C	RECEIVE 1
24	26 AWG WHT	8	R4	1	S	P3	25	C	RECEIVE 2

## 33279G6 – 9-Pin FSK Loop Back Cable

Wire No.	Description of Wire	Length (inches)	From Item	From Term	From Fit	To Item	To Term	To Fit
1	26 AWG WHT	8	P7	1	C	P7	4	C
2	26 AWG WHT	8	P7	2	C	P7	5	C

## 33279G7 – 15-Pin SDLC Loop Back Cable

Wire No.	Description of Wire	Length (inches)	From Item	From Term	From Fit	To Item	To Term	To Fit
1	26 AWG WHT	8	P5	1	C	P5	5	C
2	26 AWG WHT	8	P5	3	C	P5	7	C
3	26 AWG WHT	8	P5	9	C	P5	13	C
4	26 AWG WHT	8	P5	11	C	P5	15	C

## 33279G8 – 25-Pin Port 2 Loop Back Cable

Wire No.	Description of Wire	Length (inches)	From Item	From Term	From Fit	To Item	To Term	To Fit	Remarks
1	26 AWG WHT	6.5	P2	2	C	P2	3	C	TXD/RXD
2	26 AWG WHT	6.5	P2	4	C	P2	5	C	RTS/CTS
3	26 AWG WHT	6.5	P2	20	C	P2	6	C	DTR/DSR-TO NEXT WIRE
4	26 AWG WHT	6.5	P2	6	C	P2	8	C	DSR/DCD

## 100-1044-501 – 20-Pin Telemetry Interface Loopback Connector

(mates to connector in front-panel slot used for optional modules)

Pins Listed Together are Soldered Together
5, 6
8, 9, 10, 11
13, 14
15, 16, 17

## 33279G10 – 9-Pin Port 3A Test Cable

Wire No.	Description of Wire	Length (inches)	From Item	From Term	From Fit	To Item	To Term	To Fit
1	26 AWG WHT	8	P1	1	C	P1	7	C
2	26 AWG WHT	8	P1	2	C	P1	3	C

## Ethernet Crossover Cable

P1	to P2
1	3
2	6
3	1
4	2
5	4
6	5
7	7
8	8

## 32864G1 – ASC-2S/1000 Power Cable

Item #	Wire	Length (inches)	From/Term	To/Term
1	18 AWG GRN	6	P1-H	P1-SHL
2	PWR CORD 18 AWG 3 COND	72	P1-C	PWR-BLK (AC+)
3	PWR CORD 18 AWG 3 COND	72	P1-A	PWR-WHT (AC-)
4	PWR CORD 18 AWG 3 COND	72	P1-H	PWR-GRN (CG)



# Pretimed Controller Operation

## General Information

Pretimed operation provides the capability to extend walk on selected phases. Extending walk means that the walk interval is expanded from its programmed time to an interval equal to the phase's maximum green minus ped clearance plus any ped clearance timed during the phase's yellow or yellow plus red clearance.

Use MM-2-7 to select the phases whose ped services are to be timed by the "Pretimed Operation." Pretimed phases are automatically converted to non-actuated phases with vehicle recall.

## Pretimed Operation

The diagram below shows how a pretimed ped service is timed. Even though the phase is converted to non-actuated operation, the phase's maximum green is used to establish the length of the walk. Normally, the length of the walk will be the maximum green time for the phase minus the time required by the ped clearance. However, if Coordinator is not free, a hold is applied at end of walk, or the ped clear through yellow or yellow plus red option is applied, the length of the pretimed walk may be reduced to the programmed walk or expanded beyond the phase's maximum green.

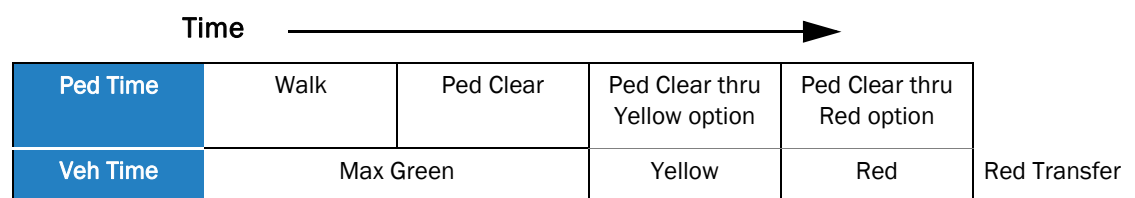

Because a pretimed phase operates in non-actuated mode, the presence of a hold input when the walk completes its timing will result in the walk signal being held on and the ped service not being allowed to advance to ped clear. When the hold input is lifted, the ped service will advance to ped clearance if there is an opposing call or if there is no opposing call and the walk rest modifier isn't applied.

As would be expected, the application of the ped clear through yellow or the ped clear through yellow and red options requires less of the ped clear to be timed during the phase's green interval and allows the walk to be extended by the amount of ped clear timed in the phase's clearance intervals. It should be noted that a pretimed walk is never allowed to extend beyond the end of the phase's green interval.

- *Appendix N*

## **Pretimed Operation During Coordinated Operation**

When the Coordinator isn't free, it uses a phase's specified split time to calculate the amount of time the phase can remain green before it must advance to its clearance intervals. During coordination, the maximum green calculated by the Coordinator replaces the phase's programmed maximum green when the length of the pretimed walk is calculated.





---

# Boot Mode Hyperterminal Transfer

(reserved for future use)

---

**For your notes:**



---

# **ASC/3-2070 Software Utility**

(reserved for future use)

---

***For your notes:***



# Diamond Intersection Application Notes

## Diamond Intersection

The indicated movements (referred to as “phases” in the specification) are really “channel” outputs. All movements except phases 2 and 6 and the 2/4/6/8 pedestrian outputs are overlaps, as shown in *Default Overlaps* on page Q-6.

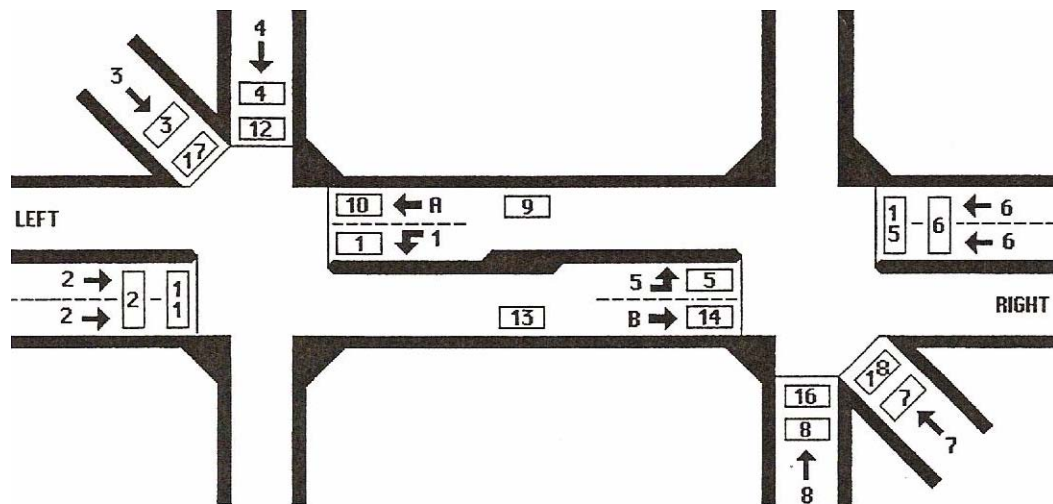

## Default Database Programming

To start Diamond Configuration, you must have a Diamond configured database loaded and active in the controller. The *ASC/3* Configurator allows the conversion of an *ASC/3* database to Diamond Configuration.

### To start a Diamond Configuration:

**IMPORTANT** • This operation is irreversible. Once a Diamond, it is always a Diamond.

- 1 Open the database file using the Configurator.

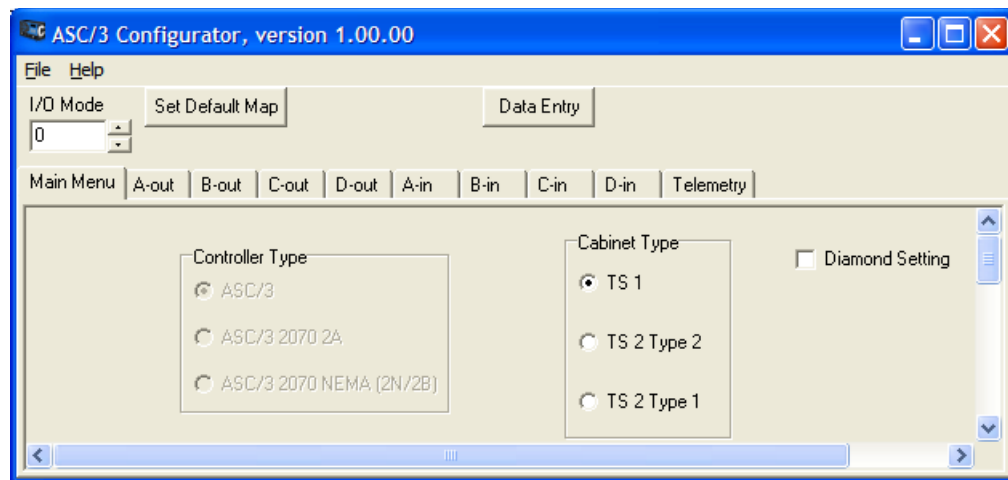

- 2 Click on the “Diamond Setting” check box. It should set all the programming values described in this appendix.
- 3 Save the database with Diamond Configuration.
- 4 Use the appropriate *ASC/3* SW Installer to download the Diamond configured database to the controller.
- 5 After the database is downloaded, you can perform additional programming using the controller’s front panel/keyboard.

### MM-1-1-5

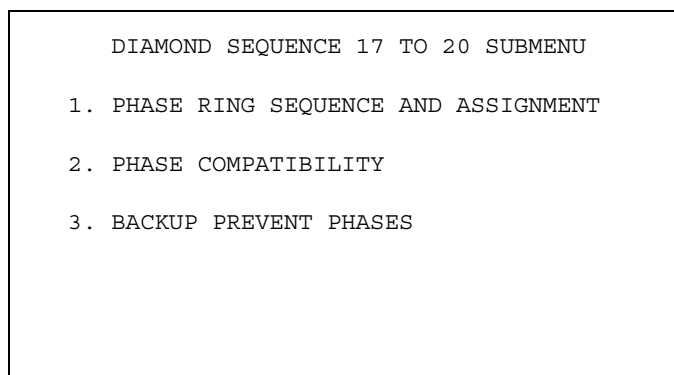

## Diamond Menus and Configurations

### Diamond Sequence & Phase Ring Assignment, MM-1-1-5-1

#### MM-1-1-5-1

PHASE RING ASSIGNMENT SEQUENCE 17 RING 1 2 3 4 9 11 12 1 0 0 0 0 RING 2 15 16 5 6 7 8 13 0 0 0 0 RING 3 0 0 0 0 0 0 0 0 0 0 0 RING 4 0 0 0 0 0 0 0 0 0 0 0  PHASE 1 2 3 4 5 6 7 8 RING..... 1 1 1 1 2 2 2 2 PHASE 9 10 11 12 13 14 15 16 RING..... 1 0 1 1 2 0 2 2  SEQUENCE 18 RING 1 10 4 9 3 2 1 0 0 0 0 0 RING 2 14 8 13 7 6 5 0 0 0 0 0 RING 3 0 0 0 0 0 0 0 0 0 0 0 RING 4 0 0 0 0 0 0 0 0 0 0 0  PHASE 1 2 3 4 5 6 7 8 RING..... 1 1 1 1 2 2 2 2 PHASE 9 10 11 12 13 14 15 16 RING..... 1 1 0 0 2 2 0 0											PHASE RING ASSIGNMENT SEQUENCE 19 RING 1 1 2 3 4 0 0 0 0 0 0 0 RING 2 5 6 7 8 0 0 0 0 0 0 0 RING 3 0 0 0 0 0 0 0 0 0 0 0 RING 4 0 0 0 0 0 0 0 0 0 0 0  PHASE 1 2 3 4 5 6 7 8 RING..... 1 1 1 1 2 2 2 2 PHASE 9 10 11 12 13 14 15 16 RING..... 0 0 0 0 0 0 0 0  SEQUENCE 20 RING 1 1 2 3 4 0 0 0 0 0 0 0 RING 2 5 6 7 8 0 0 0 0 0 0 0 RING 3 0 0 0 0 0 0 0 0 0 0 0 RING 4 0 0 0 0 0 0 0 0 0 0 0  PHASE 1 2 3 4 5 6 7 8 RING..... 1 1 1 1 2 2 2 2 PHASE 9 10 11 12 13 14 15 16 RING..... 0 0 0 0 0 0 0 0										
---	--	--	--	--	--	--	--	--	--	--	---	--	--	--	--	--	--	--	--	--	--

There are four Diamond phasing arrangements:

Sequence	Type
17 (DIA4)	Four-phase (channels)
18 (DIA3)	Three-phase (channels)
19 (DIAQ)	Eight-phase quad
20 (DIAS)	Two independent four-phase

Phase and sequence information is defined by these NTCIP objects, which are factory pre-programmed:

- phaseRing
- phaseConcurrency
- sequenceTable

This screen shows associated phase ring assignments and order-of-rotation for each Diamond configuration. Refer to MM-1-1-1 HELP for more information.

▪ Appendix Q

Diamond Phase Compatibility, MM-1-1-5-2

**MM-1-1-5-2**

<p>PHASE COMPATIBILITY SEQUENCE 17</p> <table style="width: 100%; border-collapse: collapse;"> <tr> <td></td> <td></td> <td></td> <td></td> <td></td> <td></td> <td></td> <td></td> <td></td> <td></td> <td></td> <td>1</td> <td>1</td> <td>1</td> <td>1</td> <td>1</td> <td>1</td> <td>1</td> <td></td> <td></td> </tr> <tr> <td></td> <td>1</td> <td>2</td> <td>3</td> <td>4</td> <td>5</td> <td>6</td> <td>7</td> <td>8</td> <td>9</td> <td>0</td> <td>1</td> <td>2</td> <td>3</td> <td>4</td> <td>5</td> <td>6</td> <td></td> <td></td> <td></td> </tr> <tr> <td>1</td> <td>.</td> <td>.</td> <td>.</td> <td>.</td> <td>X</td> <td>X</td> <td>X</td> <td>.</td> <td>.</td> <td>.</td> <td>.</td> <td>X</td> <td>.</td> <td>.</td> <td>.</td> <td>.</td> <td>.</td> <td>.</td> <td>.</td> </tr> <tr> <td>2</td> <td>.</td> <td>.</td> <td>.</td> <td>X</td> <td>.</td> <td>.</td> <td>.</td> <td>.</td> <td>.</td> <td>.</td> <td>.</td> <td>.</td> <td>.</td> <td>.</td> <td>.</td> <td>X</td> <td>X</td> <td>.</td> <td>.</td> </tr> <tr> <td>3</td> <td>.</td> <td>.</td> <td>.</td> <td>X</td> <td>.</td> <td>.</td> <td>.</td> <td>.</td> <td>.</td> <td>.</td> <td>.</td> <td>.</td> <td>.</td> <td>.</td> <td>.</td> <td>.</td> <td>.</td> <td>.</td> <td>.</td> </tr> <tr> <td>4</td> <td>.</td> <td>.</td> <td>.</td> <td>X</td> <td>.</td> <td>.</td> <td>.</td> <td>.</td> <td>.</td> <td>.</td> <td>.</td> <td>.</td> <td>.</td> <td>.</td> <td>.</td> <td>.</td> <td>.</td> <td>.</td> <td>.</td> </tr> <tr> <td>5</td> <td>.</td> <td>X</td> <td>X</td> <td>X</td> <td>.</td> <td>.</td> <td>.</td> <td>X</td> <td>.</td> <td>.</td> <td>.</td> <td>.</td> <td>.</td> <td>.</td> <td>.</td> <td>.</td> <td>.</td> <td>.</td> <td>.</td> </tr> <tr> <td>6</td> <td>X</td> <td>.</td> <td>.</td> <td>.</td> <td>.</td> <td>.</td> <td>.</td> <td>.</td> <td>.</td> <td>X</td> <td>X</td> <td>.</td> <td>.</td> <td>.</td> <td>.</td> <td>.</td> <td>.</td> <td>.</td> <td>.</td> </tr> <tr> <td>7</td> <td>X</td> <td>.</td> <td>.</td> <td>.</td> <td>.</td> <td>.</td> <td>.</td> <td>.</td> <td>.</td> <td>.</td> <td>.</td> <td>.</td> <td>.</td> <td>.</td> <td>.</td> <td>.</td> <td>.</td> <td>.</td> <td>.</td> </tr> <tr> <td>8</td> <td>X</td> <td>.</td> <td>.</td> <td>.</td> <td>.</td> <td>.</td> <td>.</td> <td>.</td> <td>.</td> <td>.</td> <td>.</td> <td>.</td> <td>.</td> <td>.</td> <td>.</td> <td>.</td> <td>.</td> <td>.</td> <td>.</td> </tr> <tr> <td>9</td> <td>.</td> <td>.</td> <td>.</td> <td>X</td> <td>.</td> <td>.</td> <td>.</td> <td>.</td> <td>.</td> <td>.</td> <td>.</td> <td>.</td> <td>.</td> <td>.</td> <td>.</td> <td>.</td> <td>.</td> <td>.</td> <td>.</td> </tr> <tr> <td>10</td> <td>.</td> <td>.</td> <td>.</td> <td>.</td> <td>.</td> <td>.</td> <td>.</td> <td>.</td> <td>.</td> <td>.</td> <td>.</td> <td>.</td> <td>.</td> <td>.</td> <td>.</td> <td>.</td> <td>.</td> <td>.</td> <td>.</td> </tr> <tr> <td>11</td> <td>.</td> <td>.</td> <td>.</td> <td>.</td> <td>X</td> <td>.</td> <td>.</td> <td>.</td> <td>.</td> <td>.</td> <td>.</td> <td>.</td> <td>.</td> <td>.</td> <td>.</td> <td>.</td> <td>.</td> <td>.</td> <td>.</td> </tr> <tr> <td>12</td> <td>.</td> <td>.</td> <td>.</td> <td>.</td> <td>X</td> <td>.</td> <td>.</td> <td>.</td> <td>.</td> <td>.</td> <td>.</td> <td>.</td> <td>.</td> <td>.</td> <td>.</td> <td>.</td> <td>.</td> <td>.</td> <td>.</td> </tr> <tr> <td>13</td> <td>X</td> <td>.</td> <td>.</td> <td>.</td> <td>.</td> <td>.</td> <td>.</td> <td>.</td> <td>.</td> <td>.</td> <td>.</td> <td>.</td> <td>.</td> <td>.</td> <td>.</td> <td>.</td> <td>.</td> <td>.</td> <td>.</td> </tr> <tr> <td>14</td> <td>.</td> <td>.</td> <td>.</td> <td>.</td> <td>.</td> <td>.</td> <td>.</td> <td>.</td> <td>.</td> <td>.</td> <td>.</td> <td>.</td> <td>.</td> <td>.</td> <td>.</td> <td>.</td> <td>.</td> <td>.</td> <td>.</td> </tr> <tr> <td>15</td> <td>.</td> <td>X</td> <td>.</td> <td>.</td> <td>.</td> <td>.</td> <td>.</td> <td>.</td> <td>.</td> <td>.</td> <td>.</td> <td>.</td> <td>.</td> <td>.</td> <td>.</td> <td>.</td> <td>.</td> <td>.</td> <td>.</td> </tr> <tr> <td>16</td> <td>.</td> <td>X</td> <td>.</td> <td>.</td> <td>.</td> <td>.</td> <td>.</td> <td>.</td> <td>.</td> <td>.</td> <td>.</td> <td>.</td> <td>.</td> <td>.</td> <td>.</td> <td>.</td> <td>.</td> <td>.</td> <td>.</td> </tr> </table> <p>PHASE COMPATIBILITY SEQUENCE 18</p> <table style="width: 100%; border-collapse: collapse;"> <tr> <td></td> <td></td> <td></td> <td></td> <td></td> <td></td> <td></td> <td></td> <td></td> <td></td> <td></td> <td>1</td> <td>1</td> <td>1</td> <td>1</td> <td>1</td> <td>1</td> <td>1</td> <td></td> <td></td> </tr> <tr> <td></td> <td>1</td> <td>2</td> <td>3</td> <td>4</td> <td>5</td> <td>6</td> <td>7</td> <td>8</td> <td>9</td> <td>0</td> <td>1</td> <td>2</td> <td>3</td> <td>4</td> <td>5</td> <td>6</td> <td></td> <td></td> <td></td> </tr> <tr> <td>1</td> <td>.</td> <td>.</td> <td>.</td> <td>X</td> <td>X</td> <td>.</td> <td>.</td> <td>.</td> <td>.</td> <td>.</td> <td>.</td> <td>.</td> <td>.</td> <td>.</td> <td>.</td> <td>.</td> <td>.</td> <td>.</td> <td>.</td> </tr> <tr> <td>2</td> <td>.</td> <td>.</td> <td>.</td> <td>X</td> <td>X</td> <td>.</td> <td>.</td> <td>.</td> <td>.</td> <td>.</td> <td>.</td> <td>.</td> <td>.</td> <td>.</td> <td>.</td> <td>.</td> <td>.</td> <td>.</td> <td>.</td> </tr> <tr> <td>3</td> <td>.</td> <td>.</td> <td>.</td> <td>.</td> <td>.</td> <td>X</td> <td>.</td> <td>.</td> <td>.</td> <td>.</td> <td>X</td> <td>.</td> <td>.</td> <td>.</td> <td>.</td> <td>.</td> <td>.</td> <td>.</td> <td>.</td> </tr> <tr> <td>4</td> <td>.</td> <td>.</td> <td>.</td> <td>.</td> <td>.</td> <td>.</td> <td>X</td> <td>.</td> <td>.</td> <td>.</td> <td>.</td> <td>X</td> <td>.</td> <td>.</td> <td>.</td> <td>.</td> <td>.</td> <td>.</td> <td>.</td> </tr> <tr> <td>5</td> <td>X</td> <td>X</td> <td>.</td> <td>.</td> <td>.</td> <td>.</td> <td>.</td> <td>.</td> <td>.</td> <td>.</td> <td>.</td> <td>.</td> <td>.</td> <td>.</td> <td>.</td> <td>.</td> <td>.</td> <td>.</td> <td>.</td> </tr> <tr> <td>6</td> <td>X</td> <td>X</td> <td>.</td> <td>.</td> <td>.</td> <td>.</td> <td>.</td> <td>.</td> <td>.</td> <td>.</td> <td>.</td> <td>.</td> <td>.</td> <td>.</td> <td>.</td> <td>.</td> <td>.</td> <td>.</td> <td>.</td> </tr> <tr> <td>7</td> <td>.</td> <td>X</td> <td>.</td> <td>.</td> <td>.</td> <td>.</td> <td>X</td> <td>.</td> <td>.</td> <td>.</td> <td>.</td> <td>.</td> <td>.</td> <td>.</td> <td>.</td> <td>.</td> <td>.</td> <td>.</td> <td>.</td> </tr> <tr> <td>8</td> <td>.</td> <td>.</td> <td>X</td> <td>.</td> <td>.</td> <td>.</td> <td>.</td> <td>X</td> <td>.</td> <td>.</td> <td>.</td> <td>.</td> <td>.</td> <td>.</td> <td>.</td> <td>.</td> <td>.</td> <td>.</td> <td>.</td> </tr> <tr> <td>9</td> <td>.</td> <td>.</td> <td>.</td> <td>.</td> <td>X</td> <td>.</td> <td>.</td> <td>.</td> <td>X</td> <td>.</td> <td>.</td> <td>.</td> <td>.</td> <td>.</td> <td>.</td> <td>.</td> <td>.</td> <td>.</td> <td>.</td> </tr> <tr> <td>10</td> <td>.</td> <td>.</td> <td>.</td> <td>.</td> <td>.</td> <td>X</td> <td>.</td> <td>.</td> <td>.</td> <td>X</td> <td>.</td> <td>.</td> <td>.</td> <td>.</td> <td>.</td> <td>.</td> <td>.</td> <td>.</td> <td>.</td> </tr> <tr> <td>11</td> <td>.</td> <td>.</td> <td>.</td> <td>.</td> <td>.</td> <td>.</td> <td>.</td> <td>.</td> <td>.</td> <td>.</td> <td>.</td> <td>.</td> <td>.</td> <td>.</td> <td>.</td> <td>.</td> <td>.</td> <td>.</td> <td>.</td> </tr> <tr> <td>12</td> <td>.</td> <td>.</td> <td>.</td> <td>.</td> <td>.</td> <td>.</td> <td>.</td> <td>.</td> <td>.</td> <td>.</td> <td>.</td> <td>.</td> <td>.</td> <td>.</td> <td>.</td> <td>.</td> <td>.</td> <td>.</td> <td>.</td> </tr> <tr> <td>13</td> <td>.</td> <td>X</td> <td>.</td> <td>.</td> <td>.</td> <td>.</td> <td>X</td> <td>.</td> <td>.</td> <td>.</td> <td>.</td> <td>.</td> <td>.</td> <td>.</td> <td>.</td> <td>.</td> <td>.</td> <td>.</td> <td>.</td> </tr> <tr> <td>14</td> <td>.</td> <td>.</td> <td>X</td> <td>.</td> <td>.</td> <td>.</td> <td>.</td> <td>X</td> <td>.</td> <td>.</td> <td>.</td> <td>.</td> <td>.</td> <td>.</td> <td>.</td> <td>.</td> <td>.</td> <td>.</td> <td>.</td> </tr> <tr> <td>15</td> <td>.</td> <td>.</td> <td>.</td> <td>.</td> <td>.</td> <td>.</td> <td>.</td> <td>.</td> <td>.</td> <td>.</td> <td>.</td> <td>.</td> <td>.</td> <td>.</td> <td>.</td> <td>.</td> <td>.</td> <td>.</td> <td>.</td> </tr> <tr> <td>16</td> <td>.</td> <td>.</td> <td>.</td> <td>.</td> <td>.</td> <td>.</td> <td>.</td> <td>.</td> <td>.</td> <td>.</td> <td>.</td> <td>.</td> <td>.</td> <td>.</td> <td>.</td> <td>.</td> <td>.</td> <td>.</td> <td>.</td> </tr> </table>												1	1	1	1	1	1	1				1	2	3	4	5	6	7	8	9	0	1	2	3	4	5	6				1	.	.	.	.	X	X	X	.	.	.	.	X	.	.	.	.	.	.	.	2	.	.	.	X	.	.	.	.	.	.	.	.	.	.	.	X	X	.	.	3	.	.	.	X	.	.	.	.	.	.	.	.	.	.	.	.	.	.	.	4	.	.	.	X	.	.	.	.	.	.	.	.	.	.	.	.	.	.	.	5	.	X	X	X	.	.	.	X	.	.	.	.	.	.	.	.	.	.	.	6	X	.	.	.	.	.	.	.	.	X	X	.	.	.	.	.	.	.	.	7	X	.	.	.	.	.	.	.	.	.	.	.	.	.	.	.	.	.	.	8	X	.	.	.	.	.	.	.	.	.	.	.	.	.	.	.	.	.	.	9	.	.	.	X	.	.	.	.	.	.	.	.	.	.	.	.	.	.	.	10	.	.	.	.	.	.	.	.	.	.	.	.	.	.	.	.	.	.	.	11	.	.	.	.	X	.	.	.	.	.	.	.	.	.	.	.	.	.	.	12	.	.	.	.	X	.	.	.	.	.	.	.	.	.	.	.	.	.	.	13	X	.	.	.	.	.	.	.	.	.	.	.	.	.	.	.	.	.	.	14	.	.	.	.	.	.	.	.	.	.	.	.	.	.	.	.	.	.	.	15	.	X	.	.	.	.	.	.	.	.	.	.	.	.	.	.	.	.	.	16	.	X	.	.	.	.	.	.	.	.	.	.	.	.	.	.	.	.	.												1	1	1	1	1	1	1				1	2	3	4	5	6	7	8	9	0	1	2	3	4	5	6				1	.	.	.	X	X	.	.	.	.	.	.	.	.	.	.	.	.	.	.	2	.	.	.	X	X	.	.	.	.	.	.	.	.	.	.	.	.	.	.	3	.	.	.	.	.	X	.	.	.	.	X	.	.	.	.	.	.	.	.	4	.	.	.	.	.	.	X	.	.	.	.	X	.	.	.	.	.	.	.	5	X	X	.	.	.	.	.	.	.	.	.	.	.	.	.	.	.	.	.	6	X	X	.	.	.	.	.	.	.	.	.	.	.	.	.	.	.	.	.	7	.	X	.	.	.	.	X	.	.	.	.	.	.	.	.	.	.	.	.	8	.	.	X	.	.	.	.	X	.	.	.	.	.	.	.	.	.	.	.	9	.	.	.	.	X	.	.	.	X	.	.	.	.	.	.	.	.	.	.	10	.	.	.	.	.	X	.	.	.	X	.	.	.	.	.	.	.	.	.	11	.	.	.	.	.	.	.	.	.	.	.	.	.	.	.	.	.	.	.	12	.	.	.	.	.	.	.	.	.	.	.	.	.	.	.	.	.	.	.	13	.	X	.	.	.	.	X	.	.	.	.	.	.	.	.	.	.	.	.	14	.	.	X	.	.	.	.	X	.	.	.	.	.	.	.	.	.	.	.	15	.	.	.	.	.	.	.	.	.	.	.	.	.	.	.	.	.	.	.	16	.	.	.	.	.	.	.	.	.	.	.	.	.	.	.	.	.	.	.	<p>PHASE COMPATIBILITY SEQUENCE 19</p> <table style="width: 100%; border-collapse: collapse;"> <tr> <td></td> <td></td> <td></td> <td></td> <td></td> <td></td> <td></td> <td></td> <td></td> <td></td> <td></td> <td></td> <td>1</td> <td>1</td> <td>1</td> <td>1</td> <td>1</td> <td>1</td> <td>1</td> <td></td> </tr> <tr> <td></td> <td>1</td> <td>2</td> <td>3</td> <td>4</td> <td>5</td> <td>6</td> <td>7</td> <td>8</td> <td>9</td> <td>0</td> <td>1</td> <td>2</td> <td>3</td> <td>4</td> <td>5</td> <td>6</td> <td></td> <td></td> <td></td> </tr> <tr> <td>1</td> <td>.</td> <td>.</td> <td>.</td> <td>X</td> <td>X</td> <td>X</td> <td>X</td> <td>.</td> <td>.</td> <td>.</td> <td>.</td> <td>.</td> <td>.</td> <td>.</td> <td>.</td> <td>.</td> <td>.</td> <td>.</td> <td>.</td> </tr> <tr> <td>2</td> <td>.</td> <td>.</td> <td>.</td> <td>X</td> <td>X</td> <td>X</td> <td>X</td> <td>.</td> <td>.</td> <td>.</td> <td>.</td> <td>.</td> <td>.</td> <td>.</td> <td>.</td> <td>.</td> <td>.</td> <td>.</td> <td>.</td> </tr> <tr> <td>3</td> <td>.</td> <td>.</td> <td>.</td> <td>X</td> <td>X</td> <td>X</td> <td>X</td> <td>.</td> <td>.</td> <td>.</td> <td>.</td> <td>.</td> <td>.</td> <td>.</td> <td>.</td> <td>.</td> <td>.</td> <td>.</td> <td>.</td> </tr> <tr> <td>4</td> <td>.</td> <td>.</td> <td>.</td> <td>X</td> <td>X</td> <td>X</td> <td>X</td> <td>.</td> <td>.</td> <td>.</td> <td>.</td> <td>.</td> <td>.</td> <td>.</td> <td>.</td> <td>.</td> <td>.</td> <td>.</td> <td>.</td> </tr> <tr> <td>5</td> <td>X</td> <td>X</td> <td>X</td> <td>X</td> <td>.</td> <td>.</td> <td>.</td> <td>.</td> <td>.</td> <td>.</td> <td>.</td> <td>.</td> <td>.</td> <td>.</td> <td>.</td> <td>.</td> <td>.</td> <td>.</td> <td>.</td> </tr> <tr> <td>6</td> <td>X</td> <td>X</td> <td>X</td> <td>X</td> <td>.</td> <td>.</td> <td>.</td> <td>.</td> <td>.</td> <td>.</td> <td>.</td> <td>.</td> <td>.</td> <td>.</td> <td>.</td> <td>.</td> <td>.</td> <td>.</td> <td>.</td> </tr> <tr> <td>7</td> <td>X</td> <td>X</td> <td>X</td> <td>X</td> <td>.</td> <td>.</td> <td>.</td> <td>.</td> <td>.</td> <td>.</td> <td>.</td> <td>.</td> <td>.</td> <td>.</td> <td>.</td> <td>.</td> <td>.</td> <td>.</td> <td>.</td> </tr> <tr> <td>8</td> <td>X</td> <td>X</td> <td>X</td> <td>X</td> <td>.</td> <td>.</td> <td>.</td> <td>.</td> <td>.</td> <td>.</td> <td>.</td> <td>.</td> <td>.</td> <td>.</td> <td>.</td> <td>.</td> <td>.</td> <td>.</td> <td>.</td> </tr> <tr> <td>9</td> <td>.</td> <td>.</td> <td>.</td> <td>.</td> <td>.</td> <td>.</td> <td>.</td> <td>.</td> <td>.</td> <td>.</td> <td>.</td> <td>.</td> <td>.</td> <td>.</td> <td>.</td> <td>.</td> <td>.</td> <td>.</td> <td>.</td> </tr> <tr> <td>10</td> <td>.</td> <td>.</td> <td>.</td> <td>.</td> <td>.</td> <td>.</td> <td>.</td> <td>.</td> <td>.</td> <td>.</td> <td>.</td> <td>.</td> <td>.</td> <td>.</td> <td>.</td> <td>.</td> <td>.</td> <td>.</td> <td>.</td> </tr> <tr> <td>11</td> <td>.</td> <td>.</td> <td>.</td> <td>.</td> <td>.</td> <td>.</td> <td>.</td> <td>.</td> <td>.</td> <td>.</td> <td>.</td> <td>.</td> <td>.</td> <td>.</td> <td>.</td> <td>.</td> <td>.</td> <td>.</td> <td>.</td> </tr> <tr> <td>12</td> <td>.</td> <td>.</td> <td>.</td> <td>.</td> <td>.</td> <td>.</td> <td>.</td> <td>.</td> <td>.</td> <td>.</td> <td>.</td> <td>.</td> <td>.</td> <td>.</td> <td>.</td> <td>.</td> <td>.</td> <td>.</td> <td>.</td> </tr> <tr> <td>13</td> <td>.</td> <td>.</td> <td>.</td> <td>.</td> <td>.</td> <td>.</td> <td>.</td> <td>.</td> <td>.</td> <td>.</td> <td>.</td> <td>.</td> <td>.</td> <td>.</td> <td>.</td> <td>.</td> <td>.</td> <td>.</td> <td>.</td> </tr> <tr> <td>14</td> <td>.</td> <td>.</td> <td>.</td> <td>.</td> <td>.</td> <td>.</td> <td>.</td> <td>.</td> <td>.</td> <td>.</td> <td>.</td> <td>.</td> <td>.</td> <td>.</td> <td>.</td> <td>.</td> <td>.</td> <td>.</td> <td>.</td> </tr> <tr> <td>15</td> <td>.</td> <td>.</td> <td>.</td> <td>.</td> <td>.</td> <td>.</td> <td>.</td> <td>.</td> <td>.</td> <td>.</td> <td>.</td> <td>.</td> <td>.</td> <td>.</td> <td>.</td> <td>.</td> <td>.</td> <td>.</td> <td>.</td> </tr> <tr> <td>16</td> <td>.</td> <td>.</td> <td>.</td> <td>.</td> <td>.</td> <td>.</td> <td>.</td> <td>.</td> <td>.</td> <td>.</td> <td>.</td> <td>.</td> <td>.</td> <td>.</td> <td>.</td> <td>.</td> <td>.</td> <td>.</td> <td>.</td> </tr> </table> <p>PHASE COMPATIBILITY SEQUENCE 20</p> <table style="width: 100%; border-collapse: collapse;"> <tr> <td></td> <td></td> <td></td> <td></td> <td></td> <td></td> <td></td> <td></td> <td></td> <td></td> <td></td> <td></td> <td>1</td> <td>1</td> <td>1</td> <td>1</td> <td>1</td> <td>1</td> <td>1</td> <td></td> </tr> <tr> <td></td> <td>1</td> <td>2</td> <td>3</td> <td>4</td> <td>5</td> <td>6</td> <td>7</td> <td>8</td> <td>9</td> <td>0</td> <td>1</td> <td>2</td> <td>3</td> <td>4</td> <td>5</td> <td>6</td> <td></td> <td></td> <td></td> </tr> <tr> <td>1</td> <td>.</td> <td>.</td> <td>.</td> <td>X</td> <td>X</td> <td>.</td> <td>.</td> <td>.</td> <td>.</td> <td>.</td> <td>.</td> <td>.</td> <td>.</td> <td>.</td> <td>.</td> <td>.</td> <td>.</td> <td>.</td> <td>.</td> </tr> <tr> <td>2</td> <td>.</td> <td>.</td> <td>.</td> <td>X</td> <td>X</td> <td>.</td> <td>.</td> <td>.</td> <td>.</td> <td>.</td> <td>.</td> <td>.</td> <td>.</td> <td>.</td> <td>.</td> <td>.</td> <td>.</td> <td>.</td> <td>.</td> </tr> <tr> <td>3</td> <td>.</td> <td>.</td> <td>.</td> <td>.</td> <td>.</td> <td>X</td> <td>X</td> <td>.</td> <td>.</td> <td>.</td> <td>.</td> <td>.</td> <td>.</td> <td>.</td> <td>.</td> <td>.</td> <td>.</td> <td>.</td> <td>.</td> </tr> <tr> <td>4</td> <td>.</td> <td>.</td> <td>.</td> <td>.</td> <td>.</td> <td>X</td> <td>X</td> <td>.</td> <td>.</td> <td>.</td> <td>.</td> <td>.</td> <td>.</td> <td>.</td> <td>.</td> <td>.</td> <td>.</td> <td>.</td> <td>.</td> </tr> <tr> <td>5</td> <td>X</td> <td>X</td> <td>.</td> <td>.</td> <td>.</td> <td>.</td> <td>.</td> <td>.</td> <td>.</td> <td>.</td> <td>.</td> <td>.</td> <td>.</td> <td>.</td> <td>.</td> <td>.</td> <td>.</td> <td>.</td> <td>.</td> </tr> <tr> <td>6</td> <td>X</td> <td>X</td> <td>.</td> <td>.</td> <td>.</td> <td>.</td> <td>.</td> <td>.</td> <td>.</td> <td>.</td> <td>.</td> <td>.</td> <td>.</td> <td>.</td> <td>.</td> <td>.</td> <td>.</td> <td>.</td> <td>.</td> </tr> <tr> <td>7</td> <td>.</td> <td>X</td> <td>X</td> <td>.</td> <td>.</td> <td>.</td> <td>.</td> <td>.</td> <td>.</td> <td>.</td> <td>.</td> <td>.</td> <td>.</td> <td>.</td> <td>.</td> <td>.</td> <td>.</td> <td>.</td> <td>.</td> </tr> <tr> <td>8</td> <td>.</td> <td>X</td> <td>X</td> <td>.</td> <td>.</td> <td>.</td> <td>.</td> <td>.</td> <td>.</td> <td>.</td> <td>.</td> <td>.</td> <td>.</td> <td>.</td> <td>.</td> <td>.</td> <td>.</td> <td>.</td> <td>.</td> </tr> <tr> <td>9</td> <td>.</td> <td>.</td> <td>.</td> <td>.</td> <td>.</td> <td>.</td> <td>.</td> <td>.</td> <td>.</td> <td>.</td> <td>.</td> <td>.</td> <td>.</td> <td>.</td> <td>.</td> <td>.</td> <td>.</td> <td>.</td> <td>.</td> </tr> <tr> <td>10</td> <td>.</td> <td>.</td> <td>.</td> <td>.</td> <td>.</td> <td>.</td> <td>.</td> <td>.</td> <td>.</td> <td>.</td> <td>.</td> <td>.</td> <td>.</td> <td>.</td> <td>.</td> <td>.</td> <td>.</td> <td>.</td> <td>.</td> </tr> <tr> <td>11</td> <td>.</td> <td>.</td> <td>.</td> <td>.</td> <td>.</td> <td>.</td> <td>.</td> <td>.</td> <td>.</td> <td>.</td> <td>.</td> <td>.</td> <td>.</td> <td>.</td> <td>.</td> <td>.</td> <td>.</td> <td>.</td> <td>.</td> </tr> <tr> <td>12</td> <td>.</td> <td>.</td> <td>.</td> <td>.</td> <td>.</td> <td>.</td> <td>.</td> <td>.</td> <td>.</td> <td>.</td> <td>.</td> <td>.</td> <td>.</td> <td>.</td> <td>.</td> <td>.</td> <td>.</td> <td>.</td> <td>.</td> </tr> <tr> <td>13</td> <td>.</td> <td>.</td> <td>.</td> <td>.</td> <td>.</td> <td>.</td> <td>.</td> <td>.</td> <td>.</td> <td>.</td> <td>.</td> <td>.</td> <td>.</td> <td>.</td> <td>.</td> <td>.</td> <td>.</td> <td>.</td> <td>.</td> </tr> <tr> <td>14</td> <td>.</td> <td>.</td> <td>.</td> <td>.</td> <td>.</td> <td>.</td> <td>.</td> <td>.</td> <td>.</td> <td>.</td> <td>.</td> <td>.</td> <td>.</td> <td>.</td> <td>.</td> <td>.</td> <td>.</td> <td>.</td> <td>.</td> </tr> <tr> <td>15</td> <td>.</td> <td>.</td> <td>.</td> <td>.</td> <td>.</td> <td>.</td> <td>.</td> <td>.</td> <td>.</td> <td>.</td> <td>.</td> <td>.</td> <td>.</td> <td>.</td> <td>.</td> <td>.</td> <td>.</td> <td>.</td> <td>.</td> </tr> <tr> <td>16</td> <td>.</td> <td>.</td> <td>.</td> <td>.</td> <td>.</td> <td>.</td> <td>.</td> <td>.</td> <td>.</td> <td>.</td> <td>.</td> <td>.</td> <td>.</td> <td>.</td> <td>.</td> <td>.</td> <td>.</td> <td>.</td> <td>.</td> </tr> </table>													1	1	1	1	1	1	1			1	2	3	4	5	6	7	8	9	0	1	2	3	4	5	6				1	.	.	.	X	X	X	X	.	.	.	.	.	.	.	.	.	.	.	.	2	.	.	.	X	X	X	X	.	.	.	.	.	.	.	.	.	.	.	.	3	.	.	.	X	X	X	X	.	.	.	.	.	.	.	.	.	.	.	.	4	.	.	.	X	X	X	X	.	.	.	.	.	.	.	.	.	.	.	.	5	X	X	X	X	.	.	.	.	.	.	.	.	.	.	.	.	.	.	.	6	X	X	X	X	.	.	.	.	.	.	.	.	.	.	.	.	.	.	.	7	X	X	X	X	.	.	.	.	.	.	.	.	.	.	.	.	.	.	.	8	X	X	X	X	.	.	.	.	.	.	.	.	.	.	.	.	.	.	.	9	.	.	.	.	.	.	.	.	.	.	.	.	.	.	.	.	.	.	.	10	.	.	.	.	.	.	.	.	.	.	.	.	.	.	.	.	.	.	.	11	.	.	.	.	.	.	.	.	.	.	.	.	.	.	.	.	.	.	.	12	.	.	.	.	.	.	.	.	.	.	.	.	.	.	.	.	.	.	.	13	.	.	.	.	.	.	.	.	.	.	.	.	.	.	.	.	.	.	.	14	.	.	.	.	.	.	.	.	.	.	.	.	.	.	.	.	.	.	.	15	.	.	.	.	.	.	.	.	.	.	.	.	.	.	.	.	.	.	.	16	.	.	.	.	.	.	.	.	.	.	.	.	.	.	.	.	.	.	.													1	1	1	1	1	1	1			1	2	3	4	5	6	7	8	9	0	1	2	3	4	5	6				1	.	.	.	X	X	.	.	.	.	.	.	.	.	.	.	.	.	.	.	2	.	.	.	X	X	.	.	.	.	.	.	.	.	.	.	.	.	.	.	3	.	.	.	.	.	X	X	.	.	.	.	.	.	.	.	.	.	.	.	4	.	.	.	.	.	X	X	.	.	.	.	.	.	.	.	.	.	.	.	5	X	X	.	.	.	.	.	.	.	.	.	.	.	.	.	.	.	.	.	6	X	X	.	.	.	.	.	.	.	.	.	.	.	.	.	.	.	.	.	7	.	X	X	.	.	.	.	.	.	.	.	.	.	.	.	.	.	.	.	8	.	X	X	.	.	.	.	.	.	.	.	.	.	.	.	.	.	.	.	9	.	.	.	.	.	.	.	.	.	.	.	.	.	.	.	.	.	.	.	10	.	.	.	.	.	.	.	.	.	.	.	.	.	.	.	.	.	.	.	11	.	.	.	.	.	.	.	.	.	.	.	.	.	.	.	.	.	.	.	12	.	.	.	.	.	.	.	.	.	.	.	.	.	.	.	.	.	.	.	13	.	.	.	.	.	.	.	.	.	.	.	.	.	.	.	.	.	.	.	14	.	.	.	.	.	.	.	.	.	.	.	.	.	.	.	.	.	.	.	15	.	.	.	.	.	.	.	.	.	.	.	.	.	.	.	.	.	.	.	16	.	.	.	.	.	.	.	.	.	.	.	.	.	.	.	.	.	.	.
											1	1	1	1	1	1	1																																																																																																																																																																																																																																																																																																																																																																																																																																																																																																																																																																																																																																																																																																																																																																																																																																																																																																																																																																																																																																																																																																																																																																																																																																																																																																																																																																																																																																																																																
	1	2	3	4	5	6	7	8	9	0	1	2	3	4	5	6																																																																																																																																																																																																																																																																																																																																																																																																																																																																																																																																																																																																																																																																																																																																																																																																																																																																																																																																																																																																																																																																																																																																																																																																																																																																																																																																																																																																																																																																																	
1	.	.	.	.	X	X	X	.	.	.	.	X	.	.	.	.	.	.	.																																																																																																																																																																																																																																																																																																																																																																																																																																																																																																																																																																																																																																																																																																																																																																																																																																																																																																																																																																																																																																																																																																																																																																																																																																																																																																																																																																																																																																																																														
2	.	.	.	X	.	.	.	.	.	.	.	.	.	.	.	X	X	.	.																																																																																																																																																																																																																																																																																																																																																																																																																																																																																																																																																																																																																																																																																																																																																																																																																																																																																																																																																																																																																																																																																																																																																																																																																																																																																																																																																																																																																																																																														
3	.	.	.	X	.	.	.	.	.	.	.	.	.	.	.	.	.	.	.																																																																																																																																																																																																																																																																																																																																																																																																																																																																																																																																																																																																																																																																																																																																																																																																																																																																																																																																																																																																																																																																																																																																																																																																																																																																																																																																																																																																																																																																														
4	.	.	.	X	.	.	.	.	.	.	.	.	.	.	.	.	.	.	.																																																																																																																																																																																																																																																																																																																																																																																																																																																																																																																																																																																																																																																																																																																																																																																																																																																																																																																																																																																																																																																																																																																																																																																																																																																																																																																																																																																																																																																																														
5	.	X	X	X	.	.	.	X	.	.	.	.	.	.	.	.	.	.	.																																																																																																																																																																																																																																																																																																																																																																																																																																																																																																																																																																																																																																																																																																																																																																																																																																																																																																																																																																																																																																																																																																																																																																																																																																																																																																																																																																																																																																																																														
6	X	.	.	.	.	.	.	.	.	X	X	.	.	.	.	.	.	.	.																																																																																																																																																																																																																																																																																																																																																																																																																																																																																																																																																																																																																																																																																																																																																																																																																																																																																																																																																																																																																																																																																																																																																																																																																																																																																																																																																																																																																																																																														
7	X	.	.	.	.	.	.	.	.	.	.	.	.	.	.	.	.	.	.																																																																																																																																																																																																																																																																																																																																																																																																																																																																																																																																																																																																																																																																																																																																																																																																																																																																																																																																																																																																																																																																																																																																																																																																																																																																																																																																																																																																																																																																														
8	X	.	.	.	.	.	.	.	.	.	.	.	.	.	.	.	.	.	.																																																																																																																																																																																																																																																																																																																																																																																																																																																																																																																																																																																																																																																																																																																																																																																																																																																																																																																																																																																																																																																																																																																																																																																																																																																																																																																																																																																																																																																																														
9	.	.	.	X	.	.	.	.	.	.	.	.	.	.	.	.	.	.	.																																																																																																																																																																																																																																																																																																																																																																																																																																																																																																																																																																																																																																																																																																																																																																																																																																																																																																																																																																																																																																																																																																																																																																																																																																																																																																																																																																																																																																																																														
10	.	.	.	.	.	.	.	.	.	.	.	.	.	.	.	.	.	.	.																																																																																																																																																																																																																																																																																																																																																																																																																																																																																																																																																																																																																																																																																																																																																																																																																																																																																																																																																																																																																																																																																																																																																																																																																																																																																																																																																																																																																																																																														
11	.	.	.	.	X	.	.	.	.	.	.	.	.	.	.	.	.	.	.																																																																																																																																																																																																																																																																																																																																																																																																																																																																																																																																																																																																																																																																																																																																																																																																																																																																																																																																																																																																																																																																																																																																																																																																																																																																																																																																																																																																																																																																														
12	.	.	.	.	X	.	.	.	.	.	.	.	.	.	.	.	.	.	.																																																																																																																																																																																																																																																																																																																																																																																																																																																																																																																																																																																																																																																																																																																																																																																																																																																																																																																																																																																																																																																																																																																																																																																																																																																																																																																																																																																																																																																																														
13	X	.	.	.	.	.	.	.	.	.	.	.	.	.	.	.	.	.	.																																																																																																																																																																																																																																																																																																																																																																																																																																																																																																																																																																																																																																																																																																																																																																																																																																																																																																																																																																																																																																																																																																																																																																																																																																																																																																																																																																																																																																																																														
14	.	.	.	.	.	.	.	.	.	.	.	.	.	.	.	.	.	.	.																																																																																																																																																																																																																																																																																																																																																																																																																																																																																																																																																																																																																																																																																																																																																																																																																																																																																																																																																																																																																																																																																																																																																																																																																																																																																																																																																																																																																																																																														
15	.	X	.	.	.	.	.	.	.	.	.	.	.	.	.	.	.	.	.																																																																																																																																																																																																																																																																																																																																																																																																																																																																																																																																																																																																																																																																																																																																																																																																																																																																																																																																																																																																																																																																																																																																																																																																																																																																																																																																																																																																																																																																														
16	.	X	.	.	.	.	.	.	.	.	.	.	.	.	.	.	.	.	.																																																																																																																																																																																																																																																																																																																																																																																																																																																																																																																																																																																																																																																																																																																																																																																																																																																																																																																																																																																																																																																																																																																																																																																																																																																																																																																																																																																																																																																																														
											1	1	1	1	1	1	1																																																																																																																																																																																																																																																																																																																																																																																																																																																																																																																																																																																																																																																																																																																																																																																																																																																																																																																																																																																																																																																																																																																																																																																																																																																																																																																																																																																																																																																																																
	1	2	3	4	5	6	7	8	9	0	1	2	3	4	5	6																																																																																																																																																																																																																																																																																																																																																																																																																																																																																																																																																																																																																																																																																																																																																																																																																																																																																																																																																																																																																																																																																																																																																																																																																																																																																																																																																																																																																																																																																	
1	.	.	.	X	X	.	.	.	.	.	.	.	.	.	.	.	.	.	.																																																																																																																																																																																																																																																																																																																																																																																																																																																																																																																																																																																																																																																																																																																																																																																																																																																																																																																																																																																																																																																																																																																																																																																																																																																																																																																																																																																																																																																																														
2	.	.	.	X	X	.	.	.	.	.	.	.	.	.	.	.	.	.	.																																																																																																																																																																																																																																																																																																																																																																																																																																																																																																																																																																																																																																																																																																																																																																																																																																																																																																																																																																																																																																																																																																																																																																																																																																																																																																																																																																																																																																																																														
3	.	.	.	.	.	X	.	.	.	.	X	.	.	.	.	.	.	.	.																																																																																																																																																																																																																																																																																																																																																																																																																																																																																																																																																																																																																																																																																																																																																																																																																																																																																																																																																																																																																																																																																																																																																																																																																																																																																																																																																																																																																																																																														
4	.	.	.	.	.	.	X	.	.	.	.	X	.	.	.	.	.	.	.																																																																																																																																																																																																																																																																																																																																																																																																																																																																																																																																																																																																																																																																																																																																																																																																																																																																																																																																																																																																																																																																																																																																																																																																																																																																																																																																																																																																																																																																														
5	X	X	.	.	.	.	.	.	.	.	.	.	.	.	.	.	.	.	.																																																																																																																																																																																																																																																																																																																																																																																																																																																																																																																																																																																																																																																																																																																																																																																																																																																																																																																																																																																																																																																																																																																																																																																																																																																																																																																																																																																																																																																																														
6	X	X	.	.	.	.	.	.	.	.	.	.	.	.	.	.	.	.	.																																																																																																																																																																																																																																																																																																																																																																																																																																																																																																																																																																																																																																																																																																																																																																																																																																																																																																																																																																																																																																																																																																																																																																																																																																																																																																																																																																																																																																																																														
7	.	X	.	.	.	.	X	.	.	.	.	.	.	.	.	.	.	.	.																																																																																																																																																																																																																																																																																																																																																																																																																																																																																																																																																																																																																																																																																																																																																																																																																																																																																																																																																																																																																																																																																																																																																																																																																																																																																																																																																																																																																																																																														
8	.	.	X	.	.	.	.	X	.	.	.	.	.	.	.	.	.	.	.																																																																																																																																																																																																																																																																																																																																																																																																																																																																																																																																																																																																																																																																																																																																																																																																																																																																																																																																																																																																																																																																																																																																																																																																																																																																																																																																																																																																																																																																														
9	.	.	.	.	X	.	.	.	X	.	.	.	.	.	.	.	.	.	.																																																																																																																																																																																																																																																																																																																																																																																																																																																																																																																																																																																																																																																																																																																																																																																																																																																																																																																																																																																																																																																																																																																																																																																																																																																																																																																																																																																																																																																																														
10	.	.	.	.	.	X	.	.	.	X	.	.	.	.	.	.	.	.	.																																																																																																																																																																																																																																																																																																																																																																																																																																																																																																																																																																																																																																																																																																																																																																																																																																																																																																																																																																																																																																																																																																																																																																																																																																																																																																																																																																																																																																																																														
11	.	.	.	.	.	.	.	.	.	.	.	.	.	.	.	.	.	.	.																																																																																																																																																																																																																																																																																																																																																																																																																																																																																																																																																																																																																																																																																																																																																																																																																																																																																																																																																																																																																																																																																																																																																																																																																																																																																																																																																																																																																																																																														
12	.	.	.	.	.	.	.	.	.	.	.	.	.	.	.	.	.	.	.																																																																																																																																																																																																																																																																																																																																																																																																																																																																																																																																																																																																																																																																																																																																																																																																																																																																																																																																																																																																																																																																																																																																																																																																																																																																																																																																																																																																																																																																														
13	.	X	.	.	.	.	X	.	.	.	.	.	.	.	.	.	.	.	.																																																																																																																																																																																																																																																																																																																																																																																																																																																																																																																																																																																																																																																																																																																																																																																																																																																																																																																																																																																																																																																																																																																																																																																																																																																																																																																																																																																																																																																																														
14	.	.	X	.	.	.	.	X	.	.	.	.	.	.	.	.	.	.	.																																																																																																																																																																																																																																																																																																																																																																																																																																																																																																																																																																																																																																																																																																																																																																																																																																																																																																																																																																																																																																																																																																																																																																																																																																																																																																																																																																																																																																																																														
15	.	.	.	.	.	.	.	.	.	.	.	.	.	.	.	.	.	.	.																																																																																																																																																																																																																																																																																																																																																																																																																																																																																																																																																																																																																																																																																																																																																																																																																																																																																																																																																																																																																																																																																																																																																																																																																																																																																																																																																																																																																																																																														
16	.	.	.	.	.	.	.	.	.	.	.	.	.	.	.	.	.	.	.																																																																																																																																																																																																																																																																																																																																																																																																																																																																																																																																																																																																																																																																																																																																																																																																																																																																																																																																																																																																																																																																																																																																																																																																																																																																																																																																																																																																																																																																														
												1	1	1	1	1	1	1																																																																																																																																																																																																																																																																																																																																																																																																																																																																																																																																																																																																																																																																																																																																																																																																																																																																																																																																																																																																																																																																																																																																																																																																																																																																																																																																																																																																																																																																															
	1	2	3	4	5	6	7	8	9	0	1	2	3	4	5	6																																																																																																																																																																																																																																																																																																																																																																																																																																																																																																																																																																																																																																																																																																																																																																																																																																																																																																																																																																																																																																																																																																																																																																																																																																																																																																																																																																																																																																																																																	
1	.	.	.	X	X	X	X	.	.	.	.	.	.	.	.	.	.	.	.																																																																																																																																																																																																																																																																																																																																																																																																																																																																																																																																																																																																																																																																																																																																																																																																																																																																																																																																																																																																																																																																																																																																																																																																																																																																																																																																																																																																																																																																														
2	.	.	.	X	X	X	X	.	.	.	.	.	.	.	.	.	.	.	.																																																																																																																																																																																																																																																																																																																																																																																																																																																																																																																																																																																																																																																																																																																																																																																																																																																																																																																																																																																																																																																																																																																																																																																																																																																																																																																																																																																																																																																																														
3	.	.	.	X	X	X	X	.	.	.	.	.	.	.	.	.	.	.	.																																																																																																																																																																																																																																																																																																																																																																																																																																																																																																																																																																																																																																																																																																																																																																																																																																																																																																																																																																																																																																																																																																																																																																																																																																																																																																																																																																																																																																																																														
4	.	.	.	X	X	X	X	.	.	.	.	.	.	.	.	.	.	.	.																																																																																																																																																																																																																																																																																																																																																																																																																																																																																																																																																																																																																																																																																																																																																																																																																																																																																																																																																																																																																																																																																																																																																																																																																																																																																																																																																																																																																																																																														
5	X	X	X	X	.	.	.	.	.	.	.	.	.	.	.	.	.	.	.																																																																																																																																																																																																																																																																																																																																																																																																																																																																																																																																																																																																																																																																																																																																																																																																																																																																																																																																																																																																																																																																																																																																																																																																																																																																																																																																																																																																																																																																														
6	X	X	X	X	.	.	.	.	.	.	.	.	.	.	.	.	.	.	.																																																																																																																																																																																																																																																																																																																																																																																																																																																																																																																																																																																																																																																																																																																																																																																																																																																																																																																																																																																																																																																																																																																																																																																																																																																																																																																																																																																																																																																																														
7	X	X	X	X	.	.	.	.	.	.	.	.	.	.	.	.	.	.	.																																																																																																																																																																																																																																																																																																																																																																																																																																																																																																																																																																																																																																																																																																																																																																																																																																																																																																																																																																																																																																																																																																																																																																																																																																																																																																																																																																																																																																																																														
8	X	X	X	X	.	.	.	.	.	.	.	.	.	.	.	.	.	.	.																																																																																																																																																																																																																																																																																																																																																																																																																																																																																																																																																																																																																																																																																																																																																																																																																																																																																																																																																																																																																																																																																																																																																																																																																																																																																																																																																																																																																																																																														
9	.	.	.	.	.	.	.	.	.	.	.	.	.	.	.	.	.	.	.																																																																																																																																																																																																																																																																																																																																																																																																																																																																																																																																																																																																																																																																																																																																																																																																																																																																																																																																																																																																																																																																																																																																																																																																																																																																																																																																																																																																																																																																														
10	.	.	.	.	.	.	.	.	.	.	.	.	.	.	.	.	.	.	.																																																																																																																																																																																																																																																																																																																																																																																																																																																																																																																																																																																																																																																																																																																																																																																																																																																																																																																																																																																																																																																																																																																																																																																																																																																																																																																																																																																																																																																																														
11	.	.	.	.	.	.	.	.	.	.	.	.	.	.	.	.	.	.	.																																																																																																																																																																																																																																																																																																																																																																																																																																																																																																																																																																																																																																																																																																																																																																																																																																																																																																																																																																																																																																																																																																																																																																																																																																																																																																																																																																																																																																																																														
12	.	.	.	.	.	.	.	.	.	.	.	.	.	.	.	.	.	.	.																																																																																																																																																																																																																																																																																																																																																																																																																																																																																																																																																																																																																																																																																																																																																																																																																																																																																																																																																																																																																																																																																																																																																																																																																																																																																																																																																																																																																																																																														
13	.	.	.	.	.	.	.	.	.	.	.	.	.	.	.	.	.	.	.																																																																																																																																																																																																																																																																																																																																																																																																																																																																																																																																																																																																																																																																																																																																																																																																																																																																																																																																																																																																																																																																																																																																																																																																																																																																																																																																																																																																																																																																														
14	.	.	.	.	.	.	.	.	.	.	.	.	.	.	.	.	.	.	.																																																																																																																																																																																																																																																																																																																																																																																																																																																																																																																																																																																																																																																																																																																																																																																																																																																																																																																																																																																																																																																																																																																																																																																																																																																																																																																																																																																																																																																																														
15	.	.	.	.	.	.	.	.	.	.	.	.	.	.	.	.	.	.	.																																																																																																																																																																																																																																																																																																																																																																																																																																																																																																																																																																																																																																																																																																																																																																																																																																																																																																																																																																																																																																																																																																																																																																																																																																																																																																																																																																																																																																																																														
16	.	.	.	.	.	.	.	.	.	.	.	.	.	.	.	.	.	.	.																																																																																																																																																																																																																																																																																																																																																																																																																																																																																																																																																																																																																																																																																																																																																																																																																																																																																																																																																																																																																																																																																																																																																																																																																																																																																																																																																																																																																																																																														
												1	1	1	1	1	1	1																																																																																																																																																																																																																																																																																																																																																																																																																																																																																																																																																																																																																																																																																																																																																																																																																																																																																																																																																																																																																																																																																																																																																																																																																																																																																																																																																																																																																																																																															
	1	2	3	4	5	6	7	8	9	0	1	2	3	4	5	6																																																																																																																																																																																																																																																																																																																																																																																																																																																																																																																																																																																																																																																																																																																																																																																																																																																																																																																																																																																																																																																																																																																																																																																																																																																																																																																																																																																																																																																																																	
1	.	.	.	X	X	.	.	.	.	.	.	.	.	.	.	.	.	.	.																																																																																																																																																																																																																																																																																																																																																																																																																																																																																																																																																																																																																																																																																																																																																																																																																																																																																																																																																																																																																																																																																																																																																																																																																																																																																																																																																																																																																																																																														
2	.	.	.	X	X	.	.	.	.	.	.	.	.	.	.	.	.	.	.																																																																																																																																																																																																																																																																																																																																																																																																																																																																																																																																																																																																																																																																																																																																																																																																																																																																																																																																																																																																																																																																																																																																																																																																																																																																																																																																																																																																																																																																														
3	.	.	.	.	.	X	X	.	.	.	.	.	.	.	.	.	.	.	.																																																																																																																																																																																																																																																																																																																																																																																																																																																																																																																																																																																																																																																																																																																																																																																																																																																																																																																																																																																																																																																																																																																																																																																																																																																																																																																																																																																																																																																																														
4	.	.	.	.	.	X	X	.	.	.	.	.	.	.	.	.	.	.	.																																																																																																																																																																																																																																																																																																																																																																																																																																																																																																																																																																																																																																																																																																																																																																																																																																																																																																																																																																																																																																																																																																																																																																																																																																																																																																																																																																																																																																																																														
5	X	X	.	.	.	.	.	.	.	.	.	.	.	.	.	.	.	.	.																																																																																																																																																																																																																																																																																																																																																																																																																																																																																																																																																																																																																																																																																																																																																																																																																																																																																																																																																																																																																																																																																																																																																																																																																																																																																																																																																																																																																																																																														
6	X	X	.	.	.	.	.	.	.	.	.	.	.	.	.	.	.	.	.																																																																																																																																																																																																																																																																																																																																																																																																																																																																																																																																																																																																																																																																																																																																																																																																																																																																																																																																																																																																																																																																																																																																																																																																																																																																																																																																																																																																																																																																														
7	.	X	X	.	.	.	.	.	.	.	.	.	.	.	.	.	.	.	.																																																																																																																																																																																																																																																																																																																																																																																																																																																																																																																																																																																																																																																																																																																																																																																																																																																																																																																																																																																																																																																																																																																																																																																																																																																																																																																																																																																																																																																																														
8	.	X	X	.	.	.	.	.	.	.	.	.	.	.	.	.	.	.	.																																																																																																																																																																																																																																																																																																																																																																																																																																																																																																																																																																																																																																																																																																																																																																																																																																																																																																																																																																																																																																																																																																																																																																																																																																																																																																																																																																																																																																																																														
9	.	.	.	.	.	.	.	.	.	.	.	.	.	.	.	.	.	.	.																																																																																																																																																																																																																																																																																																																																																																																																																																																																																																																																																																																																																																																																																																																																																																																																																																																																																																																																																																																																																																																																																																																																																																																																																																																																																																																																																																																																																																																																														
10	.	.	.	.	.	.	.	.	.	.	.	.	.	.	.	.	.	.	.																																																																																																																																																																																																																																																																																																																																																																																																																																																																																																																																																																																																																																																																																																																																																																																																																																																																																																																																																																																																																																																																																																																																																																																																																																																																																																																																																																																																																																																																														
11	.	.	.	.	.	.	.	.	.	.	.	.	.	.	.	.	.	.	.																																																																																																																																																																																																																																																																																																																																																																																																																																																																																																																																																																																																																																																																																																																																																																																																																																																																																																																																																																																																																																																																																																																																																																																																																																																																																																																																																																																																																																																																														
12	.	.	.	.	.	.	.	.	.	.	.	.	.	.	.	.	.	.	.																																																																																																																																																																																																																																																																																																																																																																																																																																																																																																																																																																																																																																																																																																																																																																																																																																																																																																																																																																																																																																																																																																																																																																																																																																																																																																																																																																																																																																																																														
13	.	.	.	.	.	.	.	.	.	.	.	.	.	.	.	.	.	.	.																																																																																																																																																																																																																																																																																																																																																																																																																																																																																																																																																																																																																																																																																																																																																																																																																																																																																																																																																																																																																																																																																																																																																																																																																																																																																																																																																																																																																																																																														
14	.	.	.	.	.	.	.	.	.	.	.	.	.	.	.	.	.	.	.																																																																																																																																																																																																																																																																																																																																																																																																																																																																																																																																																																																																																																																																																																																																																																																																																																																																																																																																																																																																																																																																																																																																																																																																																																																																																																																																																																																																																																																																														
15	.	.	.	.	.	.	.	.	.	.	.	.	.	.	.	.	.	.	.																																																																																																																																																																																																																																																																																																																																																																																																																																																																																																																																																																																																																																																																																																																																																																																																																																																																																																																																																																																																																																																																																																																																																																																																																																																																																																																																																																																																																																																																														
16	.	.	.	.	.	.	.	.	.	.	.	.	.	.	.	.	.	.	.																																																																																																																																																																																																																																																																																																																																																																																																																																																																																																																																																																																																																																																																																																																																																																																																																																																																																																																																																																																																																																																																																																																																																																																																																																																																																																																																																																																																																																																																														

There are four Diamond phasing arrangements:

Sequence	Type
17 (DIA4)	Four-phase (channels)
18 (DIA3)	Three-phase (channels)
19 (DIAQ)	Eight-phase quad
20 (DIAS)	Two independent four-phase

Phase and sequence information is defined by NTCIP objects phaseRing, phaseConcurrency, and sequenceTable for order-of-rotation. These variables are factory pre-programmed. This screen shows phase concurrency for each Diamond configuration. Refer to MM-1-1-2 HELP for more information.



### Diamond Backup Prevent, MM-1-1-5-3

#### MM-1-1-5-3

<pre> BACKUP PREVENT PHASES SEQUENCE 17          1 1 1 1 1 1 1   1 2 3 4 5 6 7 8 9 0 1 2 3 4 5 6   1 . . . . .   2 . . . . .   3 . . . . .   4 . . . . . TIMING 5 . . . . .   6 . . . . .   7 . . . . .   8 . . . . .   9 . . . . .  10 . . . . .  11 . . . . .  12 . . . . .  13 . . . . .  14 . . . . .  15 . . . . .  16 . . . . .  BACKUP PREVENT PHASES SEQUENCE 18          1 1 1 1 1 1 1   1 2 3 4 5 6 7 8 9 0 1 2 3 4 5 6   1 . . . . .   2 . . . . .   3 . . . . .   4 . . . . . TIMING 5 . . . . .   6 . . . . .   7 . . . . .   8 . . . . .   9 . . . . .  10 . . . . .  11 . . . . .  12 . . . . .  13 . . . . .  14 . . . . .  15 . . . . .  16 . . . . .                 </pre>	<pre> BACKUP PREVENT PHASES SEQUENCE 19          1 1 1 1 1 1 1   1 2 3 4 5 6 7 8 9 0 1 2 3 4 5 6   1 . . . . .   2 . . . . .   3 . . . . .   4 . . . . . TIMING 5 . . . . .   6 . . . . .   7 . . . . .   8 . . . . .   9 . . . . .  10 . . . . .  11 . . . . .  12 . . . . .  13 . . . . .  14 . . . . .  15 . . . . .  16 . . . . .  BACKUP PREVENT PHASES SEQUENCE 20          1 1 1 1 1 1 1   1 2 3 4 5 6 7 8 9 0 1 2 3 4 5 6   1 . . . . .   2 . . . . .   3 . . . . .   4 . . . . . TIMING 5 . . . . .   6 . . . . .   7 . . . . .   8 . . . . .   9 . . . . .  10 . . . . .  11 . . . . .  12 . . . . .  13 . . . . .  14 . . . . .  15 . . . . .  16 . . . . .                 </pre>
---	---

There are four Diamond phasing arrangements:

Sequence	Type
17 (DIA4)	Four-phase (channels)
18 (DIA3)	Three-phase (channels)
19 (DIAQ)	Eight-phase quad
20 (DIAS)	Two independent four-phase

This screen shows backup prevent programming for each Diamond configuration. Refer to MM-1-1-3 HELP for more information.

▪ Appendix Q

*Default Overlaps*

Overlap	Phase
A	= 1+2+9+10
B	= 5+6+13+14
I	= 1+9+10
J	= 3+11
K	= 4+12
L	= 5+13+14
M	= 7+15
N	= 8+16

*Default Channel Assignments*

Channel No.	Source (Overlap)	Type
1	9 (I)	OLP
2	2	VEH
3	10 (J)	OLP
4	11 (K)	OLP
5	12 (L)	OLP
6	6	VEH
7	13 (M)	OLP
8	14 (N)	OLP
9	1 (A)	OLP
10	2 (B)	OLP
11	3 (C)	OLP
12	4 (D)	OLP
13	2	PED
14	4	PED
15	6	PED
16	8	PED

## Selection of Diamond Phasing

Selection of Diamond phasing is done by setting the controller Sequence Number to 17, 18, 19 or 20, where the sequence numbers are associated as follows:

- Sequence 1-16 = Phasing as programmed using screens MM-1-1-1 and MM-1-1-2.
- Sequence Number 17 = Four-Phase Diamond
- Sequence Number 18 = Three-Phase Diamond
- Sequence Number 19 = NEMA Eight-Phase Standard Quad
- Sequence Number 20 = Separate Intersections (two independent four-ring controllers)

Sequences 1-16 are controller sequences associated with a 16-phase quad controller. These sequences are associated with certain phase ring assignments and concurrency configurations programmable through screens MM-1-1-1 and MM-1-1-2. This data can be read or written using NTCIP objects. The default phasing is a 16-phase quad controller. Sequences 17-20 are used to specify Diamond intersection control, as listed above.

The data entry PWR START SEQ in MM-2-5 may be programmed to any valid sequence and specifies the startup phasing/sequence. Because we have existing controller databases in the field, the variable location used to store the Power Start Sequence variable may NOT contain a zero. If you enter zero, the controller will automatically convert the entry to Sequence 1.

All *ASC/3* phasing and sequence selection, including the various Diamonds, is done as follows (in order of priority):

- 1 Hardware Inputs** – Four bits are set in the Controller Input Buffer (CIB) as signals 416 through 419 (bits A through D, respectively). These signals are set via selected controller input pins (mapped inputs) or the Logic Processor. These inputs are used *only* if HW ALT SEQ ENA (Hardware Alternate Sequence Enable) on MM-1-1-1 is set to YES.
- 2 Coordinator Active Pattern** – Refer to MM-3-2, SEQUENCE.
- 3 Time Base Active Step** – Refer to MM-5-2, SEQUENCE.
- 4 *ASC/3* Main Form** – Sequence (UpDown control, Windows only).

For the programmed settings just listed, a value of zero is “no selection”. The controller searches, in priority order, for a non-zero value, where any value between 1 and MAXSEQLIMIT (currently 20) results in a Command Sequence Number. When the controller reaches a point where the sequence change can take place, the Command Sequence Number is set as Run Sequence Number. If there are no valid selections, the controller defaults to Run Sequence Number 1. The Command and Run Sequence numbers are displayed in the lower right corner of the Main Status Display and Controller Status Display (MM-7-1). The display shows “CMD/RUN xx/yy”, where “xx” is the commanded sequence and “yy” is the running sequence.

### ▪ Appendix Q

There is a slight delay between the input selection of Sequence Number and the update of Command Sequence Number. This prevents the controller from reacting to multiple sequential changes in Command Sequence Number (a minor problem when using the Windows UpDown control). The delay is approximately one second on the *ASC/3* and five seconds on the Windows platform. On the Windows platform a message shows the “commanded” and “run” Sequence Number on the right of the Sequence UpDown switch, so the user can see the delay between the “command” and the “run” number. The message also shows the command source, where:

- **DFT** = default/startup
- **HDW** = hardware/remote inputs
- **CRD** = Coordinator
- **TBS** = Timebase
- **MFM** = Main Form selection.

### Switching Sequences/Phasing

Switching between Sequences 1-16 simply results in selection of sequence data as defined in NTCIP 1202 2.8.3.3 and as programmed using the screens at MM-1-1-1.

Switching to or from any sequence in the range 1-16 to 17, 18, 19, 20, or between any of the sequences 17 through 20 requires certain transitions of timing phases. These transitions are described as follows:

#### **If the four-phase Diamond is running:**

- Place vehicle calls everywhere, omit phases 3/4/7/8 and lift all vehicle detectors.
- When phases 5 and 9 are green, omit all phases and wait for both rings to go to green rest.
- Leave all omits applied, apply Rest in Red and wait until no phases are timing.
- If the new sequence is 18-20, remove omits on phases 1 and 5 (start phases 1 and 5). If the new sequence is 1-16, remove all omits (start phases at the top of the first concurrent group).
- Finally, set the new run sequence and terminate the sequence transfer.

**If the three-phase Diamond is running:**

- Place vehicle calls everywhere, omit all phases except 1 and 5 and lift all vehicle detectors.
- When phases 1 and 5 go green, omit all phases except 4 and 8.
- When phases 4 and 8 go green, omit all phases and wait for both phases to go to green rest.
- Leave all omits applied, and apply Rest in Red and wait until no phases are timing.
- If the new sequence is 17, remove omits on phases 2 and 5 (start phases 2 and 5). If the new sequence is 19 or 20, remove omits on phases 1 and 5 (start phases 1 and 5). In all other cases, remove all omits (start phases at the top of the first concurrent group).
- Finally, set the new run sequence and terminate the sequence transfer.

**In all other cases:**

- Place vehicle calls everywhere, omit all phases, lift all vehicle detectors, apply Rest in Red and wait until no phases are timing.
- If the new sequence is 17, remove omits on phases 2 and 5 (start phases 2 and 5). If the new sequence is 18-20 remove omits on phases 1 and 5 (start phases 1 and 5). In all other cases, remove all omits (start phases at the top of the first concurrent group).

### *Phase Timing and Detector Programming*

To provide maximum flexibility for Diamond operation, and the ability to switch dynamically between Diamond sequences, the *ASC/3* makes maximum use of the ability to store four Vehicle Timing Plans and four Vehicle Detector Plans.

Each Diamond sequence is automatically associated with Vehicle Timing Plans and Vehicle Detector Plans as follows:

- Sequence 17 – Four-Phase Diamond – Automatic selections of Vehicle Timing Plan 4 and Vehicle Detector Plan 4.
- Sequence 18 – Three-Phase Diamond – Automatic selections of Vehicle Timing Plan 3 and Vehicle Detector Plan 3.
- Sequence 1-16, 19 – NTCIP/NEMA Eight-Phase Standard Quad – Automatic selections of Vehicle Timing Plan 1 and Vehicle Detector Plan 1.
- Sequence 20 – Separate Intersections – Automatic selections of Vehicle Timing Plan 2 and Vehicle Detector Plan 2.

Programming of detectors for the Four-Phase and Three-Phase Diamonds are given in the sections discussing these operations as these are critical to correct operation. The other sequences can be programmed as the user wishes.

## Four-Phase Diamond

### Four-Phase Diamond Mode

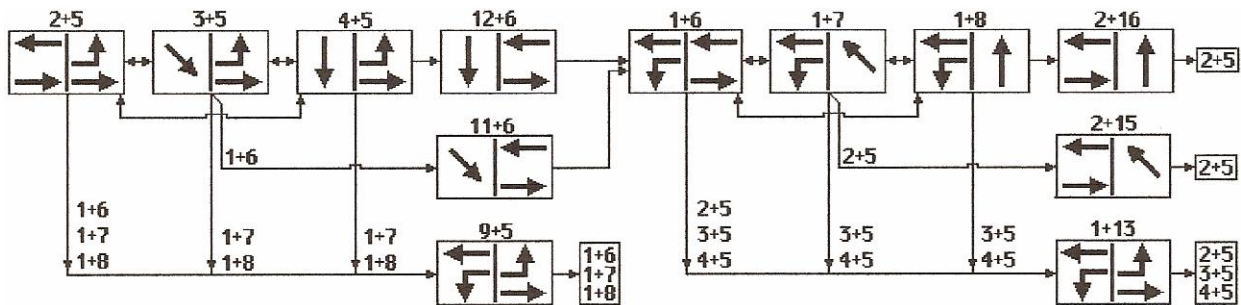

Refer to *Controller Programming Status* on page Q-25 for detailed sequence charts related to this sequence diagram.

### Sequence and Concurrency Programming

#### Ring sequence (order of rotation)

Traffic Standard ID		Standard ID
Ring 1	Ring 2	
2	15	1725
	16	1825
3	5	25
		35
		45
9	6	L-R
10 <sup>1</sup>		N/A
11	6	3516
12		4516

<sup>1</sup> Although phases 10 and 14 are shown in the ring and concurrency programming, these phases are *not* active. This is an internal operation.

Traffic Standard ID		Standard ID
Ring 1	Ring 2	
1		16
	7	17
	8	18
	13	R-L
	14 <sup>1</sup>	N/A

<sup>1</sup> Although phases 10 and 14 are shown in the ring and concurrency programming, these phases are *not* active. This is an internal operation.

### Concurrency

Phase	Ring	Concurrent Phases	Active
1	1	6-7-8-13-14	Yes
2	1	5-15-16	Yes
3	1	5	Yes
4	1	5	Yes
5	2	2-3-4-9-10	Yes
6	2	1-11-12	Yes
7	2	1	Yes
8	2	1	Yes
9	1	5	Yes
10	1	5	No
11	1	6	Yes
12	1	6	Yes
13	2	1	Yes
14	2	1	No
15	2	2	Yes
16	2	2	Yes

▪ Appendix Q

### Four-Phase Diamond Detector Programming

In the table below:

- The columns with black headings are programmed in MM-6-2, VEHICLE DETECTOR SETUP, VEHICLE DETECTOR PLAN 4, and DET NUMBERS 1-18. All other data on these screens is not programmed.
- The column with a blue heading<sup>1</sup> is programmed in MM-6-1, VEH DET TYPE / TS1 DET SELECT, DET TYPE, DET NUMBERS 1-18. All other data on this screen is not programmed. Note that this programming is the same for all Diamond detectors.

Detector Number	Assigned Phase	Switch Phase	Call Option	Passage Option	Delay Time	Extend Time	Detector Type
1	6	9	YES	NO	0.0	0.0	0
2	2	0	YES	YES	2.0	0.0	0
3	3	11	YES	YES	2.0	0.0	0
4	4	12	YES	YES	2.0	0.0	0
5	2	13	YES	NO	0.0	0.0	0
6	6	0	YES	YES	2.0	0.0	0
7	7	15	YES	YES	2.0	0.0	0
8	8	16	YES	YES	2.0	0.0	0
9	6	9	YES	NO	0.0	0.0	0
10	6	9	YES	NO	0.0	0.0	0
11	2	0	YES	YES	0.0	0.2	2
12	4	12	YES	YES	0.0	0.2	2
13	2	13	YES	NO	0.0	0.0	0
14	2	13	YES	NO	0.0	0.0	0
15	6	0	YES	YES	0.0	0.2	2
16	8	16	YES	YES	0.0	0.2	2
17	3	11	YES	YES	0.0	0.2	2
18	7	15	YES	YES	0.0	0.2	2

<sup>1</sup>. This heading appears gray in a black-and-white copy.



## Coordination

### To coordinate a Four-Phase Diamond controller:

- Split time for disabled phases must be zero.
- The sum of splits for phases 2, 3, 4, 6, 7, and 8 must equal the cycle length.
- Split time for phase 15 and phase 16 must be less than the split time for phase 2.
- Split time for phase 11 and phase 12 must be less than the split time for phase 6.
- The phase 9 split time, left to right clearance, must be less than the individual split time of phase 2, phase 3 and phase 4.
- The phase 13 split time, right to left clearance, must be less than the individual split time of phase 6, phase 7 and phase 8.
- The green time of each clearance phase, 9, 11, 12, 13, 15, and 16, is the phase split time less the yellow plus red clearance time.
- The split time for phase 5 should be at least equal to the split time of phase 2, 3, or 4.
- The split time for phase 1 should be at least equal to the split time of phase 6, 7, or 8.
- Split times for each phase must satisfy minimum phase time plus allowance for short-way (subtract) transition for the selected pattern. The minimum phase time is the larger of minimum vehicle phase time or minimum pedestrian phase time. Minimum vehicle phase time is the sum of minimum green plus yellow and red clearance times. Minimum pedestrian phase time is the sum of walk plus pedestrian clearance plus yellow and red clearance times, adjusted for pedestrian clearance through yellow or red clearance. If Added Initial is enabled, minimum vehicle green is the larger of Minimum Green or Max Initial.
- When selecting the coordinated phases, the selection of phase 2, 3, 4, 6, 7, or 8 is allowed. Phases 1 and 5 must be selected coordinated phases. The user must place the coordinated phase on recall. The selection of split time, recall and coordinated phase follows the NTCIP split table object entry for NTCIP 1202 paragraph 2.5.9.
- The controller verifies all of the above information before setting coordination active. If any of the above criteria fails, the controller will display one of the NTCIP reasons on the “coordinator status screen” for plan failure. These reasons are described in NTCIP 1202 paragraph 2.5.11.

## Three-Phase Diamond

### Three-Phase Diamond Mode

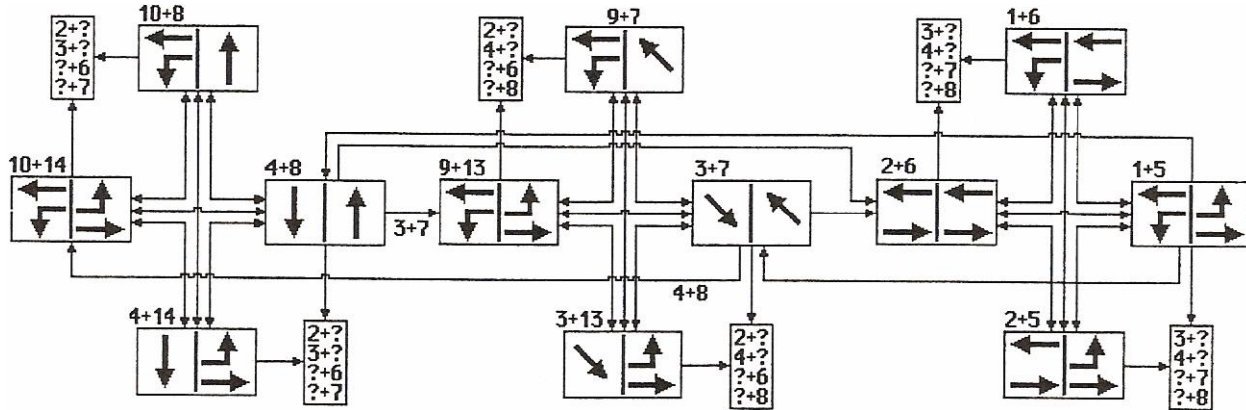

### Sequence and Concurrency Programming

#### Ring sequence (order of rotation)

Traffic Standard ID		Standard ID
Ring 1	Ring 2	
12 <sup>1</sup>	16 <sup>1</sup>	N/A
11 <sup>1</sup>	15 <sup>1</sup>	N/A
10	14	15
4	8	48
9	13	15
3	7	37
2	6	26
1	5	15

<sup>1</sup> Although phases 11, 12, 15, and 16 are shown in the ring and concurrency programming, these phases are *not* active.

**Concurrency**

Phase	Ring	Concurrent Phases	Active
1	1	5-6	Yes
2	1	5-6	Yes
3	1	7-13	Yes
4	1	8-14	Yes
5	2	1-2	Yes
6	2	1-2	Yes
7	2	3-9	Yes
8	2	4-10	Yes
9	1	7-13	Yes
10	1	8-14	Yes
11	1	15-16	No
12	1	15-16	No
13	2	3-9	Yes
14	2	4-10	Yes
15	2	11-12	No
16	2	11-12	No

▪ Appendix Q

### Three-Phase Diamond Detector Programming

In the table below:

- The columns with black headings are programmed in MM-6-2, VEHICLE DETECTOR SETUP, VEHICLE DETECTOR PLAN 3, and DET NUMBERS 1-18. All other data on these screens is not programmed.
- The column with a blue heading<sup>2</sup> is programmed in MM-6-1, VEH DET TYPE / TS1 DET SELECT, DET TYPE, DET NUMBERS 1-18. All other data on this screen is not programmed. Note that this programming is the same for all Diamond detectors.

Detector Number	Assigned Phase	Phase Called	Switch Phase	Call Option	Passage Option	Delay Time	Extend Time	Detector Type
1	1	1,9,10	0	YES	YES	0.0	0.0	0
2	2	--	0	YES	YES	2.0	0.0	0
3	3	--	0	YES	YES	2.0	0.0	0
4	4	--	0	YES	YES	2.0	0.0	0
5	5	5,13,14	0	YES	YES	0.0	0.0	0
6	6	--	1	YES	YES	2.0	0.0	0
7	7	--	0	YES	YES	2.0	0.0	0
8	8	--	0	YES	YES	2.0	0.0	0
9	9	9,10	0	YES	YES	0.0	0.0	0
10	10	9,10	0	YES	YES	0.0	0.0	0
11	2	--	0	YES	YES	0.0	0.2	2
12	4	--	0	YES	YES	0.0	0.2	2
13	13	13,14	0	YES	YES	0.0	0.0	0
14	14	13,14	0	YES	YES	0.0	0.0	0
15	6	--	0	YES	YES	0.0	0.2	2
16	8	--	0	YES	YES	0.0	0.2	2
17	3	--	0	YES	YES	0.0	0.2	2
18	7	--	0	YES	YES	0.0	0.2	2

<sup>2</sup>. This heading appears gray in a black-and-white copy.

## Coordination

### To coordinate a Three-Phase Diamond controller:

- Split time for disabled phases must be zero.
- The sum of splits for phases 4, 9, 3, 2, and 1 must equal the cycle length.
- The sum of splits for phases 8, 13, 7, 6, and 5 must equal the cycle length.
- Split time for phases 10 and 14 must be set less than or equal to split time for phase 4 and 8. The controller has internal logic to control phases 10 and 14 even though they are not part of the cycle length.
- The sum of splits for phases 1 and 2 must equal the sum of splits for phases 5 and 6.
- The sum of splits for phases 3 and 9 must equal the sum of splits for phases 7 and 13.
- The coordinated phases must be placed on recall.

## Separate Intersections

### Separate Intersection Mode

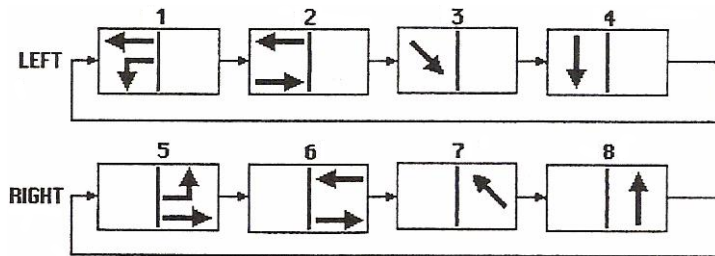

### Sequence and Concurrency Programming

#### Ring sequence (order of rotation)

Traffic Standard ID	
Ring 1	Ring 2
1	5
2	6
3	7
4	8
9 <sup>1</sup>	13 <sup>1</sup>
10 <sup>1</sup>	14 <sup>1</sup>
11 <sup>1</sup>	15 <sup>1</sup>
12 <sup>1</sup>	16 <sup>1</sup>

<sup>1</sup> Although phases 9 through 16 are shown in the ring and concurrency programming, these phases are *not* active.

**Concurrency**

Phase	Ring	Concurrent Phases	Active
1	1	5-6-7-8-13-14-15-16	Yes
2	1	5-6-7-8-13-14-15-16	Yes
3	1	5-6-7-8-13-14-15-16	Yes
4	1	5-6-7-8-13-14-15-16	Yes
5	2	1-2-3-4-9-10-11-12	Yes
6	2	1-2-3-4-9-10-11-12	Yes
7	2	1-2-3-4-9-10-11-12	Yes
8	2	1-2-3-4-9-10-11-12	Yes
9	1	5-6-7-8-13-14-15-16	No
10	1	5-6-7-8-13-14-15-16	No
11	1	5-6-7-8-13-14-15-16	No
12	1	5-6-7-8-13-14-15-16	No
13	2	1-2-3-4-9-10-11-12	No
14	2	1-2-3-4-9-10-11-12	No
15	2	1-2-3-4-9-10-11-12	No
16	2	1-2-3-4-9-10-11-12	No

### Separate Intersection Diamond Detector Programming

In the table below:

- The columns with black headings are programmed in MM-6-2, VEHICLE DETECTOR SETUP, VEHICLE DETECTOR PLAN 2, and DET NUMBERS 1-18. All other data on these screens is not programmed.
- The column with a blue heading<sup>3</sup> is programmed in MM-6-1, VEH DET TYPE / TS1 DET SELECT, DET TYPE, DET NUMBERS 1-18. All other data on this screen is not programmed. Note that this programming is the same for all Diamond detectors.

Detector Number	Assigned Phase	Phase Called	Switch Phase	Call Option	Passage Option	Delay Time	Extend Time	Detector Type
1	1	--	0	YES	YES	0.0	0.0	0
2	2	--	0	YES	YES	0.0	0.0	0
3	3	--	0	YES	YES	0.0	0.0	0
4	4	--	0	YES	YES	0.0	0.0	0
5	5	--	0	YES	YES	0.0	0.0	0
6	6	--	0	YES	YES	0.0	0.0	0
7	7	--	0	YES	YES	0.0	0.0	0
8	8	--	0	YES	YES	0.0	0.0	0
9	1	--	2	YES	YES	0.0	0.0	0
10	1	--	2	YES	YES	0.0	0.0	0
11	2	--	0	YES	YES	0.0	0.2	2
12	4	--	0	YES	YES	0.0	0.2	2
13	5	--	6	YES	YES	0.0	0.0	0
14	5	--	6	YES	YES	0.0	0.0	0
15	6	--	0	YES	YES	0.0	0.2	2
16	8	--	0	YES	YES	0.0	0.2	2
17	3	--	0	YES	YES	0.0	0.2	2
18	7	--	0	YES	YES	0.0	0.2	2

**Note** • Disable Phases 9 through 16 (does not require programming).

<sup>3</sup>. This heading appears gray in a black-and-white copy.



## Coordination

### To coordinate a Separate Intersection controller:

- Split time for disabled phases must be zero.
- The sum of splits for phases 1, 2, 3, and 4 must equal the cycle length.
- The sum of splits for phases 5, 6, 7, and 8 must equal the cycle length.

▪ Appendix Q

**NEMA**

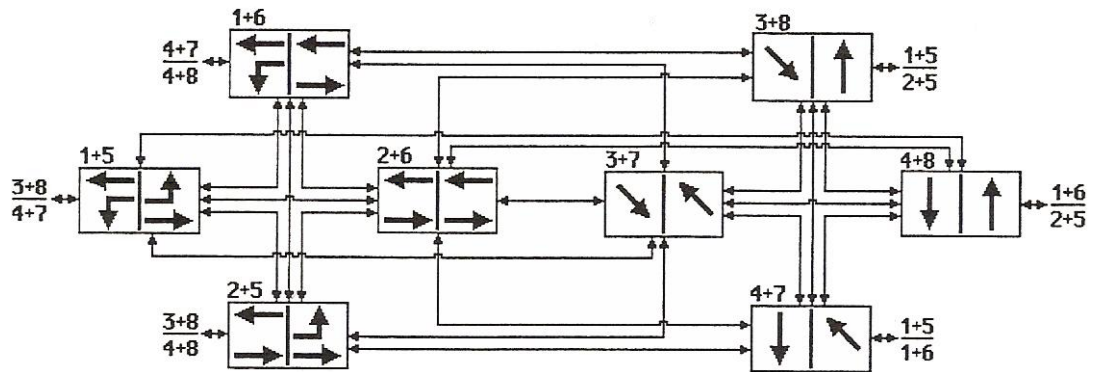

Sequence and Concurrency Programming

**Ring sequence (order of rotation)**

Traffic Standard ID	
Ring 1	Ring 2
1	5
2	6
3	7
4	8
9 <sup>1</sup>	13 <sup>1</sup>
10 <sup>1</sup>	14 <sup>1</sup>
11 <sup>1</sup>	15 <sup>1</sup>
12 <sup>1</sup>	16 <sup>1</sup>

<sup>1</sup> Although phases 9 through 16 are shown in the ring and concurrency programming, these phases are *not* active.

**Concurrency**

Phase	Ring	Concurrent Phases	Active
1	1	5-6	Yes
2	1	5-6	Yes
3	1	7-8	Yes
4	1	7-8	Yes
5	2	1-2	Yes
6	2	1-2	Yes
7	2	3-4	Yes
8	2	3-4	Yes
9	1	13-14	No
10	1	13-14	No
11	1	15-16	No
12	1	15-16	No
13	2	9-10	No
14	2	9-10	No
15	2	11-12	No
16	2	11-12	No

- *Appendix Q*

## **ASC/3 Changes**

### *Controller Start/Flash, MM-2-5, PWR START SEQ*

Refer to the Help screens for PWR START SEQ.

### *Coordinator Active Pattern, MM-3-2, SEQUENCE*

The parameter SEQUENCE allows the coordinator to select a commanded sequence in the range 0 through MAXSEQLIMIT (currently 20), where zero (0) is no selection.

### *Time Base Active Step, See MM-5-4, CONTROLLER SEQ*

The parameter SEQUENCE (previously CONTROLLER SEQ) allows the time base to select a commanded sequence in the range 0 through MAXSEQLIMIT (currently 20), where zero (0) is no selection.

### *Commanded and Runtime Sequences*

The Command and Run Sequence numbers are displayed in the lower right corner of the Main Status Display and Controller Status Display (MM-7-1). The display shows “CMD/RUN xx/yy”, where “xx” is the commanded sequence and “yy” is the running sequence.

## Controller Programming Status

### *Pre-Programmed Database Selection Menus*

There are several Diamond programming screens in the *ASC/3* controller, as shown in this section. With these screens you can view pre-programmed portions of the database related to Diamond intersections.

### **Accessing the Diamond Programming Screens**

The Controller Sequence Submenu has an option for “DIAMOND SEQUENCE 17 to 20”:

#### **MM-1-1**

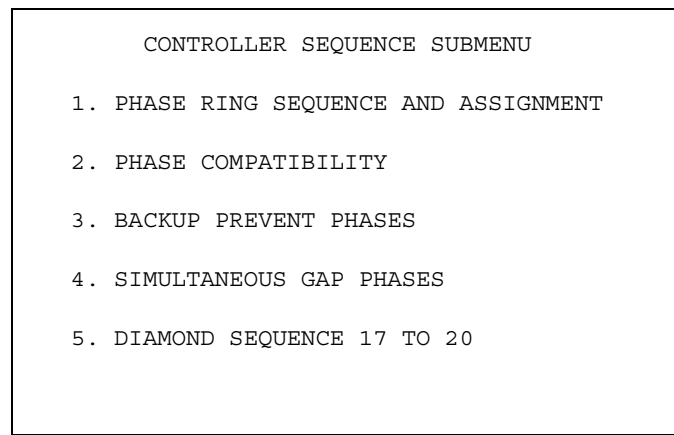

The Diamond Sequence 17 to 20 Submenu has options for three Diamond screens:

#### **MM-1-1-5**

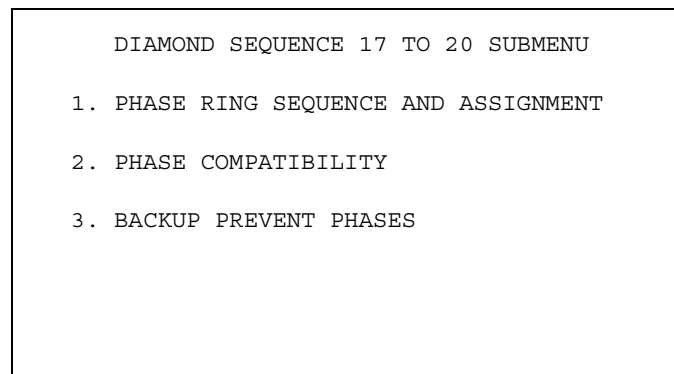

For more details about these screens, refer to the next three sections.

▪ Appendix Q

Phase Ring Sequence and Assignment Screen, MM-1-1-5-1

**MM-1-1-5-1**

<p>PHASE RING ASSIGNMENT SEQUENCE 17</p> <p>RING 1 2 3 4 9 11 12 1 0 0 0 0 0 0 0 0 0 0</p> <p>RING 2 15 16 5 6 7 8 13 0 0 0 0 0 0 0 0 0 0</p> <p>RING 3 0 0 0 0 0 0 0 0 0 0 0 0 0 0 0 0 0</p> <p>RING 4 0 0 0 0 0 0 0 0 0 0 0 0 0 0 0 0 0</p> <p style="text-align: center;">PHASE 1 2 3 4 5 6 7 8</p> <p>RING..... 1 1 1 1 2 2 2 2</p> <p style="text-align: center;">PHASE 9 10 11 12 13 14 15 16</p> <p>RING..... 1 0 1 1 2 0 2 2</p> <p>SEQUENCE 18</p> <p>RING 1 10 4 9 3 2 1 0 0 0 0 0 0 0 0 0 0 0</p> <p>RING 2 14 8 13 7 6 5 0 0 0 0 0 0 0 0 0 0 0</p> <p>RING 3 0 0 0 0 0 0 0 0 0 0 0 0 0 0 0 0 0</p> <p>RING 4 0 0 0 0 0 0 0 0 0 0 0 0 0 0 0 0 0</p> <p style="text-align: center;">PHASE 1 2 3 4 5 6 7 8</p> <p>RING..... 1 1 1 1 2 2 2 2</p> <p style="text-align: center;">PHASE 9 10 11 12 13 14 15 16</p> <p>RING..... 1 1 0 0 2 2 0 0</p>	<p>PHASE RING ASSIGNMENT SEQUENCE 19</p> <p>RING 1 1 2 3 4 0 0 0 0 0 0 0 0 0 0 0 0 0</p> <p>RING 2 5 6 7 8 0 0 0 0 0 0 0 0 0 0 0 0 0</p> <p>RING 3 0 0 0 0 0 0 0 0 0 0 0 0 0 0 0 0 0</p> <p>RING 4 0 0 0 0 0 0 0 0 0 0 0 0 0 0 0 0 0</p> <p style="text-align: center;">PHASE 1 2 3 4 5 6 7 8</p> <p>RING..... 1 1 1 1 2 2 2 2</p> <p style="text-align: center;">PHASE 9 10 11 12 13 14 15 16</p> <p>RING..... 0 0 0 0 0 0 0 0</p> <p>SEQUENCE 20</p> <p>RING 1 1 2 3 4 0 0 0 0 0 0 0 0 0 0 0 0 0</p> <p>RING 2 5 6 7 8 0 0 0 0 0 0 0 0 0 0 0 0 0</p> <p>RING 3 0 0 0 0 0 0 0 0 0 0 0 0 0 0 0 0 0</p> <p>RING 4 0 0 0 0 0 0 0 0 0 0 0 0 0 0 0 0 0</p> <p style="text-align: center;">PHASE 1 2 3 4 5 6 7 8</p> <p>RING..... 1 1 1 1 2 2 2 2</p> <p style="text-align: center;">PHASE 9 10 11 12 13 14 15 16</p> <p>RING..... 0 0 0 0 0 0 0 0</p>
--	--

Phase Compatibility Screen, MM-1-1-5-2

**MM-1-1-5-2**

<p>PHASE COMPATIBILITY</p> <p>SEQUENCE 17</p> <p>1 2 3 4 5 6 7 8 9 0 1 2 3 4 5 6</p> <p>1 . . . . X X X . . . . X . . .</p> <p>2 . . . . X . . . . . . . . X X</p> <p>3 . . . . X . . . . . . . . . .</p> <p>4 . . . . X . . . . . . . . . .</p> <p>5 . X X X . . . . X . . . . . . .</p> <p>6 X . . . . . . . . X X . . . . .</p> <p>7 X . . . . . . . . . . . . . . .</p> <p>8 X . . . . . . . . . . . . . . .</p> <p>9 . . . . X . . . . . . . . . . .</p> <p>10 . . . . . . . . . . . . . . . .</p> <p>11 . . . . . X . . . . . . . . . .</p> <p>12 . . . . . X . . . . . . . . . .</p> <p>13 X . . . . . . . . . . . . . . .</p> <p>14 . . . . . . . . . . . . . . . .</p> <p>15 . X . . . . . . . . . . . . . .</p> <p>16 . X . . . . . . . . . . . . . .</p>	<p>PHASE COMPATIBILITY</p> <p>SEQUENCE 19</p> <p>1 2 3 4 5 6 7 8 9 0 1 2 3 4 5 6</p> <p>1 . . . . X X X X . . . . . . . .</p> <p>2 . . . . X X X X . . . . . . . .</p> <p>3 . . . . X X X X . . . . . . . .</p> <p>4 . . . . X X X X . . . . . . . .</p> <p>5 X X X X . . . . . . . . . . . .</p> <p>6 X X X X . . . . . . . . . . . .</p> <p>7 X X X X . . . . . . . . . . . .</p> <p>8 X X X X . . . . . . . . . . . .</p> <p>9 . . . . . . . . . . . . . . . .</p> <p>10 . . . . . . . . . . . . . . . .</p> <p>11 . . . . . . . . . . . . . . . .</p> <p>12 . . . . . . . . . . . . . . . .</p> <p>13 . . . . . . . . . . . . . . . .</p> <p>14 . . . . . . . . . . . . . . . .</p> <p>15 . . . . . . . . . . . . . . . .</p> <p>16 . . . . . . . . . . . . . . . .</p>
<p>PHASE COMPATIBILITY</p> <p>SEQUENCE 18</p> <p>1 2 3 4 5 6 7 8 9 0 1 2 3 4 5 6</p> <p>1 . . . . X X . . . . . . . . . .</p> <p>2 . . . . X X . . . . . . . . . .</p> <p>3 . . . . . X . . . . . . . . X . .</p> <p>4 . . . . . . . X . . . . . . . X . .</p> <p>5 X X . . . . . . . . . . . . . .</p> <p>6 X X . . . . . . . . . . . . . .</p> <p>7 . . X . . . . . X . . . . . . . .</p> <p>8 . . . X . . . . . X . . . . . . .</p> <p>9 . . . . . X . . . . . X . . . . .</p> <p>10 . . . . . . X . . . . . X . . . . .</p> <p>11 . . . . . . . . . . . . . . . .</p> <p>12 . . . . . . . . . . . . . . . .</p> <p>13 . . X . . . . . X . . . . . . . .</p> <p>14 . . . X . . . . . X . . . . . . .</p> <p>15 . . . . . . . . . . . . . . . .</p> <p>16 . . . . . . . . . . . . . . . .</p>	<p>PHASE COMPATIBILITY</p> <p>SEQUENCE 20</p> <p>1 2 3 4 5 6 7 8 9 0 1 2 3 4 5 6</p> <p>1 . . . . X X . . . . . . . . . .</p> <p>2 . . . . X X . . . . . . . . . .</p> <p>3 . . . . . X X . . . . . . . . . .</p> <p>4 . . . . . . X X . . . . . . . . . .</p> <p>5 X X . . . . . . . . . . . . . .</p> <p>6 X X . . . . . . . . . . . . . .</p> <p>7 . . X X . . . . . . . . . . . .</p> <p>8 . . X X . . . . . . . . . . . .</p> <p>9 . . . . . . . . . . . . . . . .</p> <p>10 . . . . . . . . . . . . . . . .</p> <p>11 . . . . . . . . . . . . . . . .</p> <p>12 . . . . . . . . . . . . . . . .</p> <p>13 . . . . . . . . . . . . . . . .</p> <p>14 . . . . . . . . . . . . . . . .</p> <p>15 . . . . . . . . . . . . . . . .</p> <p>16 . . . . . . . . . . . . . . . .</p>

▪ Appendix Q

Backup Prevent Phases Screen, MM-1-1-5-3

**MM-1-1-5-3**

<pre> BACKUP PREVENT PHASES          v &gt; SEQUENCE 17                    1 1 1 1 1 1 1   1 2 3 4 5 6 7 8 9 0 1 2 3 4 5 6   1 . . . . .   2 . . . . .   3 . . . . .   4 . . . . .   5 . . . . .   6 . . . . .   7 . . . . .   8 . . . . .   9 . . . . .  10 . . . . .  11 . . . . .  12 . . . . .  13 . . . . .  14 . . . . .  15 . . . . .  16 . . . . .  BACKUP PREVENT PHASES SEQUENCE 18                    1 1 1 1 1 1 1   1 2 3 4 5 6 7 8 9 0 1 2 3 4 5 6   1 . . . . .   2 . . . . .   3 . . . . .   4 . . . . .   5 . . . . .   6 . . . . .   7 . . . . .   8 . . . . .   9 . . . . .  10 . . . . .  11 . . . . .  12 . . . . .  13 . . . . .  14 . . . . .  15 . . . . .  16 . . . . . </pre>	<pre> BACKUP PREVENT PHASES          v &gt; SEQUENCE 19                    1 1 1 1 1 1 1   1 2 3 4 5 6 7 8 9 0 1 2 3 4 5 6   1 . . . . .   2 . . . . .   3 . . . . .   4 . . . . .   5 . . . . .   6 . . . . .   7 . . . . .   8 . . . . .   9 . . . . .  10 . . . . .  11 . . . . .  12 . . . . .  13 . . . . .  14 . . . . .  15 . . . . .  16 . . . . .  BACKUP PREVENT PHASES SEQUENCE 20                    1 1 1 1 1 1 1   1 2 3 4 5 6 7 8 9 0 1 2 3 4 5 6   1 . . . . .   2 . . . . .   3 . . . . .   4 . . . . .   5 . . . . .   6 . . . . .   7 . . . . .   8 . . . . .   9 . . . . .  10 . . . . .  11 . . . . .  12 . . . . .  13 . . . . .  14 . . . . .  15 . . . . .  16 . . . . . </pre>
---	---



## NEMA Sequence Charts for Four-Phase Diamond

The tables in this section are sequence charts for the Diamond Four-Phase Diamond Mode. Note the tables have a left and right side. On the left are the channel/overlap colors, on the right are the corresponding phase/overlap colors. The four columns on each side show channels/phases/overlaps for Ring 1, Overlap A, Ring 2, and Overlap B.

### Sequences Starting From Phases 2 and 5

Channel/Overlap				Phase/Overlap			
<b>From 25 to 35</b>							
2G	AG	5G	BG	2G	AG	5G	BG
2Y	AY	5G	BG	2Y	AY	5G	BG
3G	AR	5G	BG	3G	AR	5G	BG
<b>From 25 to 45</b>							
2G	AG	5G	BG	2G	AG	5G	BG
2Y	AY	5G	BG	2Y	AY	5G	BG
4G	AR	5G	BG	4G	AR	5G	BG
<b>From 25 to 16</b>				<b>R1 uses overlap I (1 + 9)</b>			
2G	AG	5G	BG	2G	AG	5G	BG
2Y	AG	5G	BG	2Y	AG	5G	BG
1G	AG	5G	BG	9G	AG	5G	BG
1G	AG	5Y	BG	9Y	AG	5Y	BG
1G	AG	6G	BG	1G	AG	6G	BG
<b>From 25 to 17/18</b>				<b>R1 uses overlap I (1 + 9)</b>			
2G	AG	5G	BG	2G	AG	5G	BG
2Y	AG	5G	BG	2Y	AG	5G	BG
1G	AG	5G	BG	9G	AG	5G	BG
1G	AG	5Y	BY	9Y	AG	5Y	BY
1G	AG	7G	BR	1G	AG	7G	BR
1G	AG	8G	BR	1G	AG	8G	BR

▪ Appendix Q

Sequences Starting From Phases 3 and 5

Channel/Overlap				Phase/Overlap			
<b>From 35 to 25</b>							
3G	AR	5G	BG	3G	AR	5G	BG
3Y	AR	5G	BG	3Y	AR	5G	BG
2G	AG	5G	BG	2G	AG	5G	BG
<b>From 35 to 45</b>							
3G	AR	5G	BG	3G	AR	5G	BG
3Y	AR	5G	BG	3Y	AR	5G	BG
4G	AR	5G	BG	4G	AR	5G	BG
<b>From 35 to 16</b>				<b>R1 uses overlap J (3 + 11)</b>			
3G	AR	5G	BG	3G	AR	5G	BG
3G	AR	5Y	BG	3Y	AR	5Y	BG
3G	AR	6G	BG	11G	AR	6G	BG
3Y	AR	6G	BG	11Y	AR	6G	BG
1G	AG	6G	BG	1G	AG	6G	BG
<b>From 35 to 17/18</b>				<b>R1 uses overlap I (1 + 9)</b>			
3G	AR	5G	BG	3G	AR	5G	BG
3Y	AR	5G	BG	3Y	AR	5G	BG
1G	AG	5G	BG	9G	AG	5G	BG
1G	AG	5Y	BY	9Y	AG	5Y	BY
1G	AG	7G	BR	1G	AG	7G	BR
1G	AG	8G	BR	1G	AG	8G	BR

## Sequences Starting From Phases 4 and 5

Channel/Overlap				Phase/Overlap			
<b>From 45 to 25</b>							
4G	AR	5G	BG	4G	AR	5G	BG
4Y	AR	5G	BG	4Y	AR	5G	BG
2G	AG	5G	BG	2G	AG	5G	BG
<b>From 45 to 35</b>							
4G	AR	5G	BG	4G	AR	5G	BG
4Y	AR	5G	BG	4Y	AR	5G	BG
3G	AR	5G	BG	3G	AR	5G	BG
<b>From 45 to 16</b>				<b>R1 uses overlap K (4 +12)</b>			
4G	AR	5G	BG	4G	AR	5G	BG
4G	AR	5Y	BG	4Y	AR	5Y	BG
4G	AR	6G	BG	12G	AR	6G	BG
4Y	AR	6G	BG	12Y	AR	6G	BG
1G	AG	6G	BG	1G	AG	6G	BG
<b>From 45 to 17/18</b>				<b>R1 uses overlap I (1 + 9)</b>			
4G	AR	5G	BG	4G	AR	5G	BG
4Y	AR	5G	BG	4Y	AR	5G	BG
1G	AG	5G	BG	9G	AG	5G	BG
1G	AG	5Y	BY	9Y	AG	5Y	BY
1G	AG	7G	BR	1G	AG	7G	BR
1G	AG	8G	BR	1G	AG	8G	BR

▪ Appendix Q

Sequences Starting From Phases 1 and 6

Channel/Overlap				Phase/Overlap			
<b>From 16 to 17</b>							
1G	AG	6G	BG	1G	AG	6G	BG
1G	AG	6Y	BY	1G	AG	6Y	BY
1G	AG	7G	BR	1G	AG	7G	BR
<b>From 16 to 18</b>							
1G	AG	6G	BG	1G	AG	6G	BG
1G	AG	6Y	BY	1G	AG	6Y	BY
1G	AG	8G	BR	1G	AG	8G	BR
<b>From 16 to 25</b>				<b>R2 uses overlap L (5 +13)</b>			
1G	AG	6G	BG	1G	AG	6G	BG
1G	AG	6Y	BG	1G	AG	6Y	BG
1G	AG	5G	BG	1G	AG	13G	BG
1Y	AG	5G	BG	1Y	AG	13Y	BG
2G	AG	5G	BG	2G	AG	5G	BG
<b>From 16 to 35/45</b>				<b>R2 uses overlap L (5 +13)</b>			
1G	AG	6G	BG	1G	AG	6G	BG
1G	AG	6Y	BG	1G	AG	6Y	BG
1G	AG	5G	BG	1G	AG	13G	BG
1Y	AY	5G	BG	1Y	AY	13Y	BG
3G	AR	5G	BG	3G	AR	5G	BG
4G	AR	5G	BG	4G	AR	5G	BG

## Sequences Starting From Phases 1 and 7

Channel/Overlap				Phase/Overlap			
<b>From 17 to 16</b>							
1G	AG	7G	BR	1G	AG	7G	BR
1G	AG	7Y	BR	1G	AG	7Y	BR
1G	AG	6G	BG	1G	AG	6G	BG
<b>From 17 to 18</b>							
1G	AG	7G	BR	1G	AG	7G	BR
1G	AG	7Y	BR	1G	AG	7Y	BR
1G	AG	8G	BR	1G	AG	8G	BR
<b>From 17 to 25</b>				<b>R2 uses overlap M (7 +15)</b>			
1G	AG	7G	BR	1G	AG	7G	BR
1Y	AG	7G	BR	1Y	AG	7Y	BR
2G	AG	7G	BR	2G	AG	15G	BR
2G	AG	7Y	BR	2G	AG	15Y	BR
2G	AG	5G	BG	2G	AG	5G	BG
<b>From 17 to 35/45</b>				<b>R2 uses overlap L (5 +13)</b>			
1G	AG	7G	BR	1G	AG	7G	BR
1G	AG	7Y	BR	1G	AG	7Y	BR
1G	AG	5G	BG	1G	AG	13G	BG
1Y	AY	5G	BG	1Y	AY	13Y	BG
3G	AR	5G	BG	3G	AR	5G	BG
4G	AR	5G	BG	4G	AR	5G	BG

▪ Appendix Q

Sequences Starting From Phases 1 and 8

Channel/Overlap				Phase/Overlap			
<b>From 18 to 16</b>							
1G	AG	8G	BR	1G	AG	8G	BR
1G	AG	8Y	BR	1G	AG	8Y	BR
1G	AG	6G	BG	1G	AG	6G	BG
<b>From 18 to 17</b>							
1G	AG	8G	BR	1G	AG	8G	BR
1G	AG	8Y	BR	1G	AG	8Y	BR
1G	AG	7G	BR	1G	AG	7G	BR
<b>From 18 to 25</b>				<b>R2 uses overlap N (8 +16)</b>			
1G	AG	8G	BR	1G	AG	8G	BR
1Y	AG	8G	BR	1Y	AG	8Y	BR
2G	AG	8G	BR	2G	AG	16G	BR
2G	AG	8Y	BR	2G	AG	16Y	BR
2G	AG	5G	BG	2G	AG	5G	BG
<b>From 18 to 35/45</b>				<b>R2 uses overlap L (5 +13)</b>			
1G	AG	8G	BR	1G	AG	8G	BR
1G	AG	8Y	BR	1G	AG	8Y	BR
1G	AG	5G	BG	1G	AG	13G	BG
1Y	AY	5G	BG	1Y	AY	13Y	BG
3G	AR	5G	BG	3G	AR	5G	BG
4G	AR	5G	BG	4G	AR	5G	BG



---

## Warning Checks

Refer to [page 14-2](#) through [page 14-8](#) for displays and information about Warning Checks.

Warning Checks are a “work-in-progress” so the number of Warning Checks may increase over time and some may be deleted. The current list of Warning Checks is described in this appendix.

There are several categories of Warning Checks:

- Configuration
- Controller
- Coordinator
- Preemptor/TSP
- Time Base
- Detector

The first two numbers in the Warning Number refer to the related display. For example, for Warning 1201, refer to MM-1-2.

## Warning Checks

▪ Appendix R

### Configuration Checks

Warning No.	Configuration Warning	Description
1201	Inactive Exclusive Ped Phase	The phases below are programmed for Exclusive Pedestrian operation in MM-1-2, but are not programmed as active (in-use) in MM-1-2.
1202	In-Use Phase Not In Sequence	<p>The phases below are set as in-use in MM-1-2, but do not appear in any of the sequences programmed in MM-1-1-1.</p> <p>Please keep in mind that this warning is acceptable if the purpose of the In-Use Phase feature is to cause the controller to ignore sequence phases programmed via MM-1-1-1.</p>
1501	Intersection Monitor (IM) feature not enabled	The Port 2/C50S is enabled to run IM in MM-1-5-2, but no valid Datakey is detected. A valid Datakey is required to enable the IM feature.
1503	No Expanded System Detector Address	Local detectors assigned to System Detectors 9 thru 16 in MM-1-5-6 are ignored because the Expanded System Detector Address in MM-1-5-6 is not programmed.
1504	No Detectors for Expanded Speed Detector (SD) Address	An Expanded System Detector Address is programmed in MM-1-5-6, but no local detectors are assigned to System Detectors 9 thru 16 in MM-1-5-6.
1505	No Drop-out time on Ethernet Port	Drop-out time was set to 0 in MM-1-5-1. This disables communication on any ports with priority lower than Ethernet.
1506	No Drop-out time on Port 2/C50S	Drop-out time was set to 0 in MM-1-5-2. This disables communication on any ports with priority lower than this port.
1507	No Drop-out time on Port 3A/C21S	Drop-out time was set to 0 in MM-1-5-3. This disables communication on any ports with priority lower than this port.
1508	No Drop-out time on Port 3B/C22S	Drop-out time was set to 0 in MM-1-5-4. This disables communication on any ports with priority lower than this port.



Warning No.	Configuration Warning	Description
1509	Backup Time disabled for Ethernet	Ethernet Drop Time <i>and</i> Backup time is set to 0 in MM-1-5-1 and MM-1-5-5. This will not clear any parameters (e.g.: Phase Omit, Pedestrian Omit, Force-off, Stop Time, MAX 2, MAX Inhibit, Red Rest, Red Clear, Omit, Ped Recycle) that were commanded.
1510	Backup Time disabled for Port 3A	Port 3A Drop Time <i>and</i> Backup time set to 0 in MM-1-5-3 and MM-1-5-5. This will not clear any parameters (e.g.: Phase Omit, Pedestrian Omit, Force-off, Stop Time, MAX 2, MAX Inhibit, Red Rest, Red Clear, Omit, Ped Recycle.) that were commanded.
1511	Backup Time disabled for Port 3B	Port 3B Drop Time <i>and</i> Backup time set to 0 in MM-1-5-4 and MM-1-5-5. This will not clear any parameters (e.g.: Phase Omit, Pedestrian Omit, Force-off, Stop Time, MAX 2, MAX Inhibit, Red Rest, Red Clear, Omit, Ped Recycle) that were commanded.
1512	Backup Time disabled for Port 2	Port 2 Drop Time <i>and</i> Backup time set to 0 in MM-1-5-4 and MM-1-5-5. This will not clear any parameters (e.g.: Phase Omit, Pedestrian Omit, Force-off, Stop Time, MAX 2, MAX Inhibit, Red Rest, Red Clear, Omit, Ped Recycle) that were commanded.
1801	LP Flag in User & ExtOption stmts	The same LP Flag is programmed in <i>both</i> the user programmable LP statements (1-100) and in the Extended Option statements (101-200). This could lead to conflicts in statement execution for the listed LP flags.
1802	Invalid LP Statements enabled: KBD	Invalid Logic Processor Statements are enabled by the KBD's (MM-1-8-1) listed LP statements.
1803	Invalid LPStmts enabled: ACTION PLAN	Invalid Logic Processor Statements are enabled by one of the action plan's (MM-5-2) listed LP statements.

## Warning Checks

▪ Appendix R

### Controller Checks

Warning No.	Controller Warning	Description
2101	Minimum Green Override	<p>Phase Minimum Green timing (MM-2-1) will be overridden by Guaranteed Minimum Green (MM-2-4) on the phases listed.</p> <p>The indicated problem may be on any of four possible timing plans. Be sure to check each timing plan.</p>
2102	Walk Override	<p>Phase Walk timing (MM-2-1) will be overridden by Guaranteed Minimum Walk (MM-2-4) on the phases listed.</p> <p>The indicated problem may be on any of four possible timing plans. Be sure to check each timing plan.</p>
2103	Ped Clear Override	<p>Phase Ped Clear timing (MM-2-1) will be overridden by Guaranteed Minimum Ped Clear (MM-2-4) on the phases listed.</p> <p>The indicated problem may be on any of four possible timing plans. Be sure to check each timing plan.</p>
2104	Yellow Clear Override	<p>Phase Yellow timing (MM-2-1) will be overridden by Guaranteed Minimum Yellow (MM-2-4) on the phases listed.</p> <p>The indicated problem may be on any of four possible timing plans. Be sure to check each timing plan.</p>
2105	Red Clear Override	<p>Phase Red timing (MM-2-1) will be overridden by Guaranteed Minimum Red (MM-2-4) on the phases listed.</p> <p>The indicated problem may be on any of four possible timing plans. Be sure to check each timing plan.</p>
2106	Invalid Pedestrian Time Setting	<p>Walk <i>and</i> Pedestrian timing should both be set (MM-2-4) on the phases listed.</p> <p>The indicated problem may be on any of four possible timing plans. Be sure to check each timing plan.</p>

Warning No.	Controller Warning	Description
2107	Invalid Exclusive Ped Timing	Exclusive Pedestrian phases (MM-1-2) require non-zero Walk and Pedestrian Clear times (MM-2-1) or the Exclusive Pedestrian phase will not time. The phases listed do not have valid timing entries.  The indicated problem may be on any of four possible timing plans. Be sure to check each timing plan.
2108	Delay Green will extend Walk	If Walk time is less than Delay Green time (MM-2-1), Walk timing is automatically extended so it terminates with Delay Green. Delay Green is controlling Walk timing on the phases listed.  The indicated problem may be on any of four possible timing plans. Be sure to check each timing plan.
2109	Delay Green will extend Walk2	If Walk2 time is less than Delay Green time (MM-2-1), Walk2 timing is automatically extended so it terminates with Delay Green. Delay Green is controlling Walk2 timing on the phases listed.  The indicated problem may be on any of four possible timing plans. Be sure to check each timing plan.
2110	Phase Yellow & Guaranteed Yellow are <i>both zero</i>	No yellow will be timed because Phase Yellow timing (MM-2-1) and Guaranteed Min Yellow (MM-2-4) are both set to zero on the phases listed.  The indicated problem may be on any of four possible timing plans. Be sure to check each timing plan.
2201	Included Phase is an Exclusive Ped Phase	An Included Phase is also an XPED phase. Verify programming in MM-2-2 for the overlaps listed.
2202	Included Phase Not In-Use	An Included Phase is not part of the current sequence (MM-1-2). Verify programming in MM-2-2 for the overlaps listed.
2203	Modifier phase not in-use	A Modifier Phase is not part of the current sequence (MM-1-2). Verify programming in MM-2-2 for the overlaps listed.

## Warning Checks

▪ Appendix R

Warning No.	Controller Warning	Description
2204	Protected Phase Not In-Use	A Protected Phase is not part of the current sequence (MM-1-2). Verify programming in MM-2-2 for the overlaps listed.
2205	Pedestrian Protected Phase Not In-Use	A Ped Protect Phase is not part of the current sequence (MM-1-2). Verify programming in MM-2-2 for the overlaps listed.
2206	Lag phase Not In-Use	A Lag Phase is not part of the current sequence (MM-1-2). Verify programming in MM-2-2 for the overlaps listed.
2207	Not Overlap Phase Not In-Use	A Not Overlap Phase is not part of the current sequence (MM-1-2). Verify programming in MM-2-2 for the overlaps listed.
2208	Flashing Green Phase Not In-Use	A Flash Green Phase is not part of the current sequence (MM-1-2). Verify programming in MM-2-2 for the overlaps listed.
2209	Lead Phase Can <i>not</i> be a Protected Phase	A Lead Phase is also programmed as a Protected Phase. Verify programming in MM-2-2 for the overlaps listed.
2210	A Lag Phase Can <i>not</i> be a Protected Phase	A Lag Phase is also programmed as a Protected Phase. Verify programming in MM-2-2 for the overlaps listed.
2211	Lead Phase is <i>not</i> In-Use	A Lead Phase is not part of the current sequence (MM-1-2). Verify programming in MM-2-2 for the overlaps listed.
2213	Modifier Phase is also an Included Phase	A Modifier Phase may not also be an Included Phase. Verify programming in MM-2-2 for the overlaps listed.
2214	Not Overlap Phase is also an Included Phase	A Not Ovlp Phase may not also be an Included Phase. Verify programming in MM-2-2 for the overlaps listed.
2215	Modifier Phase Must Use Type GRN-YEL	Modifier Phase programmed but Overlap Type is not set to GRN-YEL. Verify programming in MM-2-2 for the overlaps listed.
2216	Protected Phase Must Use Type OTHER	Protected Phase programmed but Overlap Type is not set to OTHER. Verify programming in MM-2-2 for the overlaps listed.

Warning No.	Controller Warning	Description
2217	Lag Phase Must Use Type OTHER	Lag Phase programmed but Overlap Type is not set to OTHER. Verify programming in MM-2-2 for the overlaps listed.
2218	Lead Phase Must Use Type OTHER	Lead Phase programmed but Overlap Type is not set to OTHER. Verify programming in MM-2-2 for the overlaps listed.
2219	Not Overlap Phase Must Use Type OTHER	Not Olp Phase programmed but Overlap Type is not set to OTHER. Verify programming in MM-2-2 for the overlaps listed.
2220	Ped Protect Phase Must Use Type OTHER	Ped Protect Ph programmed but Overlap Type is not set to OTHER. Verify programming in MM-2-2 for the overlaps listed.
2221	Lag Phases Programmed with Invalid Timing	Lag Phase programmed but both LAG GRN and LAG YEL are not set. Verify programming in MM-2-2 for the overlaps listed.
2222	Lag GRN or YEL Programmed with No Lag Phase	Lag GRN or YEL time programmed but no Lag Phase selected. Verify programming in MM-2-2 for the overlaps listed.
2223	Lead Phases with No Advance Green Time	Lead Phase programmed but without ADV GRN time. Verify programming in MM-2-2 for the overlaps listed.
2224	Lag Phase Must be an Included Phase	A Lag phase is programmed that is not also selected as an included phase in MM-2-2 for the overlaps listed.
2225	No Lead Phase with ADV GRN Time	ADV GRN time programmed but no Lead Phase selected. Verify programming in MM-2-2 for the overlaps listed.
2501	Inactive Startup Phase	The startup phase(s) shown below, programmed in MM-2-5, are invalid because they have not been programmed as IN-USE in MM-1-2.
2502	No Startup Phase	There are no startup phases programmed in MM-2-5 for the rings shown below OR the startup phase is not programmed as IN-USE in MM-1-2.

## Warning Checks

▪ *Appendix R*

Warning No.	Controller Warning	Description
2503	No Startup Overlap	The overlaps listed below include start-up phases programmed in MM-2-5, but are not programmed as startup overlaps on that same menu. This means the overlap(s) will start in RED and revert to normal overlap operation following the first phase change.
2504	Inactive Flash Entry Phase	The phase(s) listed below are programmed as flash entry phases in MM-2-5, but are not programmed as IN-USE in MM-1-2.
2505	Invalid Flash Exit Phase	The phase(s) listed below are programmed as flash exit phases in MM-2-5, but are not programmed as IN-USE in MM-1-2.
2506	No Flash Exit Overlap	The overlaps below do not have flash exit programming in MM-2-5. On flash exit, the overlaps will display RED until a phase change.
2507	Invalid Power Start Sequence	The programmed PWR START SEQ in MM-2-5 is invalid. It should be set to a value 1 through 16 for normal operation and 17 through 20 for Diamond phasing.
2601	Invalid Dual Entry Phases	The programmed DUAL ENTRY PHASES in MM-2-6-1 are incompatible with current sequence programming. DUAL ENTRY must have a barrier to cross.
2602	Invalid Conditional Service Phases	The programmed Conditional Service phase (MM-2-6-1) is also programmed with Backup Prevent phases in MM-1-1-3. The Conditional Service feature will not function if the preceding phase is not allowed to back up from the programmed Conditional Service phase.

## Coordinator Checks

Warning No.	Coordinator Warning	Description
3101	Manual Pattern Enabled	Coordinator manual pattern is enabled in MM-3-1. Other pattern commands will be ignored.
3201	Pattern Cycle Length < 30 seconds	Cycle length (MM-3-2) is less than 30 seconds in the patterns listed.
3202	Invalid Pattern Offset	Offset (MM-3-2) is larger than the cycle length in the patterns listed.
3204	Split Sum > Cycle Length or 100%	Sum of phase splits (MM-3-3) is greater than the cycle length (MM-3-2) or 100% in the patterns listed.
3205	FLASH Option Enabled In Action Plan	FLASH option (MM-5-2) is found enabled in the following patterns' action plan (MM-3-2). It will not take effect when the programmed patterns listed are active.
3206	Xartery Split Pattern Not Programmed	Phase splits (MM-3-3) are not programmed in the listed patterns (MM-3-2) with Xartery split pattern programmed.
3207	Split Demand Pattern Not Programmed	Phase splits (MM-3-3) are not programmed in the listed patterns (MM-3-2) with split demand pattern programmed.
3208	Multiple COS mapping	The COS command (MM-3-2) is assigned to more than one pattern in the listed patterns.
3209	TSP Free Pattern Cycle Too Short	TSP free pattern cycle length (MM-3-2) is less than the sum of phase minimum in the listed timing plans.
3210	TSP Free Split Pattern not programmed	Splits are not programmed in TSP free pattern (MM-3-2).
3301	Invalid Coordinated Phases	Coordinated phases (MM-3-3) are not compatible with each other in the split patterns listed.
3302	Missing Coordinated Phase	At least one ring does not have a Coordinated phase (MM-3-3) in the split patterns listed.
3303	Split phases Not In-Use	Phase split (MM-3-3) is programmed but the phase is not programmed as an active phase in the sequences (MM-1-2) in the split patterns listed.

## Warning Checks

▪ Appendix R

Warning No.	Coordinator Warning	Description
3304	Phase with Zero Split	Setting phase split (MM-3-3) to zero will omit the phase in coordination. Zero phase splits are found in the split patterns listed.
3305	Phase Split < Phase Minimum Time	Phase split (MM-3-3) is less than the phase minimum time in the split patterns listed.  The indicated problem may be on any of four possible timing plans. Be sure to check each timing plan.

## Preemptor/TSP Checks

Warning No.	Preemptor/TSP Warning	Description
4101	Preempt Inhibit Time > Delay Time	Inhibit Time will not be honored because it must be <i>less than</i> the Delay Time. Verify programming in MM-4-1 for the preempts listed.
4102	Linked Preemptor Not Enabled	PMT run links to another PMT (MM-4-1), which is not enabled for the preempts listed.
4103	Maximum Time Enabled for High Priority Preempt	Max Presence Time (MX TM, MM-4-1) is ignored for <i>high</i> priority (Railroad) preempts. A non-zero value is programmed for the preempts listed.
4104	Maximum Time Not Programmed for <i>low</i> Priority Preempt	Max Presence Time (MX TM, MM-4-1) is not programmed for <i>low</i> Priority (EVT) preempts. Without this option, PMT will never exit if input gets stuck ON. Verify programming in MM-4-1 for the preempts listed.
4105	Track Clear MinGrn Programmed with No Track Clear Phases	Trk Clr Min Grn programmed but without TC phases. Verify programming in MM-4-1 for the preempts listed.
4106	Dwell Ped on Phase with No Ped time	Dwell Ped selected on phase with no ped time programmed. Verify programming in MM-4-1 for the preempts listed.
4107	Cycle Ped on Phase with No Ped Time	Cycle Ped selected on phase with no ped time programmed. Verify programming in MM-4-1 for the preempts listed.



Warning No.	Preemptor/TSP Warning	Description
4108	PMT MN GRN Entry time < Guar MinGrn	Preempt Minimum Green Entry time is less than Guaranteed Minimum Green. Preempt will use guaranteed time. Verify programming in MM-4-1 for the preempts listed.
4109	Preempt Minimum Green Track Clear < Guaranteed Minimum Green	Preempt Min Grn TrkClr time is less than Guar Min Green. Preempt will use guaranteed time. Verify programming in MM-4-1 for the preempts listed.
4110	Preempt YELLOW Entry time < Guaranteed Yellow	Preempt Yellow Entry time is less than Guaranteed Yellow time. Preempt will use guaranteed time. Verify programming in MM-4-1 for the preempts listed.
4111	Preempt YELLOW Track Clear Time < Guaranteed Yellow	Preempt Yellow TrkClr time is less than Guaranteed Yellow time. Preempt will use guaranteed time. Verify programming in MM-4-1 for the preempts listed.
4112	Preempt RED Entry Time < Guaranteed Red	Preempt Red Entry time is less than Guaranteed Red Clear time. Preempt will use guaranteed time. Verify programming in MM-4-1 for the preempts listed.
4113	Preempt RED Track Clear Time < Guaranteed Red	Preempt Red TrkClr time is less than Guaranteed Red Clear time. Preempt will use guaranteed time. Verify programming in MM-4-1 for the preempts listed.
4114	Preempt WALK Entry Time < Guaranteed WALK	Preempt Walk Entry time is less than Guaranteed Ped Walk time. Preempt will override guaranteed time. Verify programming in MM-4-1 for the preempts listed.
4115	Preempt Ped Clear Entry time < Guaranteed PED CLEAR	Preempt Ped Clear Entry time is less than Guaranteed Ped Clear time. Preempt will override guaranteed time. Verify programming in MM-4-1 for the preempts listed.
4116	Preempt YELLOW Entry Time < 3 seconds	Preempt Yellow Entry time is less than 3 secs. Verify programming in MM-4-1 for the preempts listed.
4117	Preempt YELLOW Track Clear Time < 3 seconds	Preempt Yellow Trk Clr time is less than 3 secs. Verify programming in MM-4-1 for the preempts listed.

**Warning Checks**

▪ *Appendix R*

<b>Warning No.</b>	<b>Preemptor/TSP Warning</b>	<b>Description</b>
4118	GateDown Incorrectly Enabled	GateDown Ext and Max Track Clear GRN must <i>both</i> be non-zero for Gate Down feature to operate. The preempt runs (MM-4-1) listed have one and not the other.
4119	PMT: MAX Trk Clr GRN is TOO SMALL	MAX Trk Clr Grn must be greater than Trk Clr Grn plus Trk Clr Gate Down Ext for the Gate Down feature to work. Verify programming in MM-4-1 for the preempts listed.
4120	PMT Track YEL > Programmed Phase YEL	Preempt Track YEL (MM-4-1) is greater than the programmed phase YEL time (MM-2-1). Programmed Phase YEL time, not PMT TRACK YEL, will be used for the preempts listed.
4121	PMT Track RED > Programmed Phase REDCLR	Preempt Track RED (MM-4-1) is greater than the programmed phase RED time (MM-2-1). Programmed Phase RED time, not PMT TRACK RED, will be used for the preempts listed.
4122	PMT Dwell YEL > Programmed Phase YEL	Preempt Dwell YEL (MM-4-1) is greater than the programmed phase YEL time (MM-2-1). The Programmed Phase YEL time, not PMT DWELL YEL, will be used for the preempts listed.
4123	PMT Dwell RED > Programmed Phase REDCLR	Preempt Dwell RED (MM-4-1) is greater than the programmed phase RED time (MM-2-1). Programmed Phase RED time, not PMT DWELL RED, will be used for the preempts listed.
4127	PMT Run not compatible with Sequences 1-16	The listed Preempt runs will not activate while controller is running Sequences 1-16.
4128	PMT Run not compatible with Sequence 17	The Preempt Run is not compatible with Diamond Sequence 17. The listed Preempt runs will not activate while controller is running Sequence 17.
4129	PMT Run not compatible with Sequence 18	The Preempt Run is not compatible with Diamond Sequence 18. The listed Preempt runs will not activate while controller is running Sequence 18.
4130	PMT Run not compatible with Sequence 19	The Preempt Run is not compatible with Diamond Sequence 19. The listed Preempt runs will not activate while controller is running Sequence 19.

Warning No.	Preemptor/TSP Warning	Description
4131	PMT Run not compatible with Sequence 20	The Preempt Run is not compatible with Diamond Sequence 20. The listed Preempt runs will not activate while controller is running Sequence 20.
4132	PMT Run is not compatible with any Sequence	The listed Preempt runs will never activate because they are not compatible with any sequence.
4201	GateDown Preempt not programmed as RR	GateDown operation only valid on <i>high priority</i> , not <i>bus</i> , preempts. Both <i>Input</i> Filters must be <i>bypassed</i> for Railroad operation. Refer to MM-4-2.
4301	TSP Feature Not Enabled	A TSP plan is enabled in MM-4-3 but no valid Datakey is detected. A valid Datakey is required to enable the TSP feature.
4302	No TSP Phases in TSP Plan	A TSP plan is enabled in MM-4-3 but no active phase is programmed as a TSP phase in the TSP plans listed.
4303	TSP Run is not compatible with Sequences 1 through 16	The TSP Run is not compatible with Sequences 1 thru 16. The listed TSP runs will not activate while the controller is running Sequences 1-16.
4304	TSP Run not compatible w/ Seq 17	The TSP Run is not compatible with Diamond Sequence 17-D4. The listed TSP runs will not activate while the controller is running that sequence.
4305	TSP Run not compatible w/ Seq 18	The TSP Run is not compatible with Diamond Sequence 18-D4. The listed TSP runs will not activate while the controller is running that sequence.
4306	TSP Run not compatible w/ Seq 19	The TSP Run is not compatible with Diamond Sequence 19-DS. The listed TSP runs will not activate while the controller is running that sequence.
4307	TSP Run not compatible w/ Seq 20	The TSP Run is not compatible with Diamond Sequence 20-DQ. The listed TSP runs will not activate while the controller is running that sequence.
4308	TSP Run is not compatible with any Sequence	The listed TSP runs will never activate because they are not compatible with any sequence.

### Time Base Checks

## Warning Checks

▪ Appendix R

Warning No.	Time Base Warning	Description
5401	No Day Plan in Schedule	Day plan (MM-5-4) is not programmed in the schedules listed.
5402	No Date is Specified in Schedule	The month, day of month or day of week (MM-5-4) is not specified in the schedules listed.
5501	No Day Plan in Exception Day Plan	Day plan (MM-5-5) is not programmed in the exception day plans listed.
5502	Invalid Day in Exception Day Plan	The month, day of month or day of week (MM-5-5) is not specified correctly in the exception day plans listed.

## Detector Checks

Warning No.	Detector Warning	Description
6101	Veh Detector on Exclusive Ped phase	<p>The vehicle detectors below are assigned to Exclusive Ped phases in MM-6-1 or MM-6-2. The assigned vehicle detector inputs have no effect on Exclusive Ped phases.</p> <p>The detector assignment may be on any of four possible detector plans. Be sure to check each vehicle detector plan.</p>
6401	Invalid Speed Detector Assignment	The local detector assigned to two-detector speed calculations in MM-6-4 <i>must</i> be an odd-numbered detector. The next even-numbered detector is automatically assigned as the second detector. The listed two-detector speed detectors have an invalid even-numbered detector assignment.



# CIB/COB Tables

## Controller Input Buffer (CIB)

Word /Bit	Bit Num	Input Signal Description	Word /Bit	Bit Num	Input Signal Description
0 0	0	Detector 1	1 0	16	Detector 17 (SD A1)
0 1	1	Detector 2	1 1	17	Detector 18 (SD A2)
0 2	2	Detector 3	1 2	18	Detector 19 (SD B1)
0 3	3	Detector 4	1 3	19	Detector 20 (SD B2)
0 4	4	Detector 5	1 4	20	Detector 21 (SD C1)
0 5	5	Detector 6	1 5	21	Detector 22 (SD C2)
0 6	6	Detector 7	1 6	22	Detector 23 (SD D1)
0 7	7	Detector 8	1 7	23	Detector 24 (SD D2)
0 8	8	Detector 9 (XD 1)	1 8	24	Detector 25
0 9	9	Detector 10 (XD 2)	1 9	25	Detector 26
0 10	10	Detector 11 (XD 3)	1 10	26	Detector 27
0 11	11	Detector 12 (XD 4)	1 11	27	Detector 28
0 12	12	Detector 13 (XD 5)	1 12	28	Detector 29
0 13	13	Detector 14 (XD 6)	1 13	29	Detector 30
0 14	14	Detector 15 (XD 7)	1 14	30	Detector 31
0 15	15	Detector 16 (XD 8)	1 15	31	Detector 32
2 0	32	Detector 33	3 0	48	Detector 49
2 1	33	Detector 34	3 1	49	Detector 50
2 2	34	Detector 35	3 2	50	Detector 51
2 3	35	Detector 36	3 3	51	Detector 52
2 4	36	Detector 37	3 4	52	Detector 53
2 5	37	Detector 38	3 5	53	Detector 54
2 6	38	Detector 39	3 6	54	Detector 55
2 7	39	Detector 40	3 7	55	Detector 56
2 8	40	Detector 41	3 8	56	Detector 57
2 9	41	Detector 42	3 9	57	Detector 58
2 10	42	Detector 43	3 10	58	Detector 59
2 11	43	Detector 44	3 11	59	Detector 60
2 12	44	Detector 45	3 12	60	Detector 61
2 13	45	Detector 46	3 13	61	Detector 62
2 14	46	Detector 47	3 14	62	Detector 63
2 15	47	Detector 48	3 15	63	Detector 64

▪ Appendix S

Word /Bit	Bit Num	Input Signal	Description	Word /Bit	Bit Num	Input Signal	Description
4 0	64	Ped Detector	1	5 0	80	Phase 1	Hold
4 1	65	Ped Detector	2	5 1	81	Phase 2	Hold
4 2	66	Ped Detector	3	5 2	82	Phase 3	Hold
4 3	67	Ped Detector	4	5 3	83	Phase 4	Hold
4 4	68	Ped Detector	5	5 4	84	Phase 5	Hold
4 5	69	Ped Detector	6	5 5	85	Phase 6	Hold
4 6	70	Ped Detector	7	5 6	86	Phase 7	Hold
4 7	71	Ped Detector	8	5 7	87	Phase 8	Hold
4 8	72	Ped Detector	9	5 8	88	Phase 9	Hold
4 9	73	Ped Detector	10	5 9	89	Phase 10	Hold
4 10	74	Ped Detector	11	5 10	90	Phase 11	Hold
4 11	75	Ped Detector	12	5 11	91	Phase 12	Hold
4 12	76	Ped Detector	13	5 12	92	Phase 13	Hold
4 13	77	Ped Detector	14	5 13	93	Phase 14	Hold
4 14	78	Ped Detector	15	5 14	94	Phase 15	Hold
4 15	79	Ped Detector	16	5 15	95	Phase 16	Hold
6 0	96	Phase 1	Omit	7 0	112	Ped Omit	Phase 1
6 1	97	Phase 2	Omit	7 1	113	Ped Omit	Phase 2
6 2	98	Phase 3	Omit	7 2	114	Ped Omit	Phase 3
6 3	99	Phase 4	Omit	7 3	115	Ped Omit	Phase 4
6 4	100	Phase 5	Omit	7 4	116	Ped Omit	Phase 5
6 5	101	Phase 6	Omit	7 5	117	Ped Omit	Phase 6
6 6	102	Phase 7	Omit	7 6	118	Ped Omit	Phase 7
6 7	103	Phase 8	Omit	7 7	119	Ped Omit	Phase 8
6 8	104	Phase 9	Omit	7 8	120	Ped Omit	Phase 9
6 9	105	Phase 10	Omit	7 9	121	Ped Omit	Phase 10
6 10	106	Phase 11	Omit	7 10	122	Ped Omit	Phase 11
6 11	107	Phase 12	Omit	7 11	123	Ped Omit	Phase 12
6 12	108	Phase 13	Omit	7 12	124	Ped Omit	Phase 13
6 13	109	Phase 14	Omit	7 13	125	Ped Omit	Phase 14
6 14	110	Phase 15	Omit	7 14	126	Ped Omit	Phase 15
6 15	111	Phase 16	Omit	7 15	127	Ped Omit	Phase 16
8 0	128	Inhibit Max Term	(R1)	9 0	144	Inhibit Max Term	(R3)
8 1	129	Max 2 Selection	(R1)	9 1	145	Max 2 Selection	(R3)
8 2	130	Max 3 Selection	(R1)	9 2	146	Max 3 Selection	(R3)
8 3	131	Omit Red Clear	(R1)	9 3	147	Omit Red Clear	(R3)
8 4	132	Red Rest	(R1)	9 4	148	Red Rest	(R3)
8 5	133	Ped Recycle	(R1)	9 5	149	Ped Recycle	(R3)
8 6	134	Force Off	(R1)	9 6	150	Force Off	(R3)
8 7	135	Stop Time	(R1)	9 7	151	Stop Time	(R3)
8 8	136	Inhibit Max Term	(R2)	9 8	152	Inhibit Max Term	(R4)
8 9	137	Max 2 Selection	(R2)	9 9	153	Max 2 Selection	(R4)
8 10	138	Max 3 Selection	(R2)	9 10	154	Max 3 Selection	(R4)
8 11	139	Omit Red Clear	(R2)	9 11	155	Omit Red Clear	(R4)
8 12	140	Red Rest	(R2)	9 12	156	Red Rest	(R4)
8 13	141	Ped Recycle	(R2)	9 13	157	Ped Recycle	(R4)
8 14	142	Force Off	(R2)	9 14	158	Force Off	(R4)
8 15	143	Stop Time	(R2)	9 15	159	Stop Time	(R4)

Word /Bit	Bit Num	Input Signal Description	Word /Bit	Bit Num	Input Signal Description
10 0	160	Test A	11 0	176	Address Bit 0
10 1	161	Test B	11 1	177	Address Bit 1
10 2	162	Test C	11 2	178	Address Bit 2
10 3	163	Test D	11 3	179	Address Bit 3
10 4	164	Test E	11 4	180	Address Bit 4
10 5	165	I/O Mode Bit A	11 5	181	Track Switch Fail
10 6	166	I/O Mode Bit B	11 6	182	Ind. Lamp Control
10 7	167	I/O Mode Bit C	11 7	183	External Start
10 8	168	Cycle Bit 1 / TP Bit A	11 8	184	Automatic (Remote) Flash
10 9	169	Cycle Bit 2 / TP Bit B	11 9	185	Flash Status/Local Flash
10 10	170	Cycle Bit 3	11 10	186	MMU Status/CMU Flash
10 11	171	Offset Bit 1	11 11	187	MMU (CMU) Stop Time
10 12	172	Offset Bit 2	11 12	188	External Time Reset
10 13	173	Offset Bit 3	11 13	189	TBC On Line
10 14	174	Split Bit 1 / TP Bit C	11 14	190	Dimming Enable
10 15	175	Split Bit 2 / TP Bit D	11 15	191	IM Power Sense
12 0	192	Coordinator Sync	13 0	208	Alarm 1
12 1	193	TLM Extern Address Enable	13 1	209	Alarm 2
12 2	194	TLM Maintenance Required	13 2	210	Alarm 3
12 3	195	Disable Pretimed Operation	13 3	211	Alarm 4
12 4	196	External Start Disable	13 4	212	Alarm 5
12 5	197	Canada Pretimed Walk Adjust	13 5	213	Alarm 6
12 6	198	TLM Spare Input 1	13 6	214	Alarm 7
12 7	199	TLM Spare Input 2	13 7	215	Alarm 8
12 8	200	Logic Processor Action Plan	13 8	216	Alarm 9
12 9	201	Logic Processor Action Plan	13 9	217	Alarm 10
12 10	202	Logic Processor Action Plan	13 10	218	Alarm 11
12 11	203	Logic Processor Action Plan	13 11	219	Alarm 12
12 12	204	Logic Processor Action Plan	13 12	220	Alarm 13
12 13	205	Logic Processor Action Plan	13 13	221	Alarm 14
12 14	206	Logic Processor Action Plan	13 14	222	Alarm 15
12 15	207	Logic Processor Action Plan	13 15	223	Alarm 16
14 0	224	Call Non-Act I	15 0	240	
14 1	225	Call Non-Act II	15 1	241	
14.2	226	Walk-Rest Modifier	15 2	242	
14 3	227	Minimum Recall	15 3	243	
14 4	228	Interval Advance	15 4	244	
14 5	229	Manual Control Enable	15 5	245	
14 6	230	Stop Time All Rings	15 6	246	
14 7	231	Phase Next in RX	15 7	247	
14 8	232	Coordinator Free	15 8	248	
14 9	233	Split Demand 1	15 9	249	
14 10	234	Split Demand 2	15 10	250	
14 11	235	Dual Coordination	15 11	251	
14 12	236		15 12	252	
14 13	237		15 13	253	
14 14	238		15 14	254	
14 15	239		15 15	255	

▪ Appendix S

Word /Bit	Bit Num	Input Signal	Description	Word /Bit	Bit Num	Input Signal	Description
16	0			17	0		
16	1			17	1		
16	2			17	2		
16	3			17	3		
16	4			17	4		
16	5			17	5		
16	6			17	6		
16	7			17	7		
16	8			17	8		
16	9			17	9		
16	10			17	10		
16	11			17	11		
16	12			17	12		
16	13			17	13		
16	14			17	14		
16	15			17	15		
18	0	Preempt	1 Call	19	0	KBD Locked Preempt	1 Call
18	1	Preempt	2 Call	19	1	KBD Locked Preempt	2 Call
18	2	Preempt	3 Call	19	2	KBD Locked Preempt	3 Call
18	3	Preempt	4 Call	19	3	KBD Locked Preempt	4 Call
18	4	Preempt	5 Call	19	4	KBD Locked Preempt	5 Call
18	5	Preempt	6 Call	19	5	KBD Locked Preempt	6 Call
18	6	Preempt	7 Call	19	6	KBD Locked Preempt	7 Call
18	7	Preempt	8 Call	19	7	KBD Locked Preempt	8 Call
18	8	Preempt	9 Call	19	8	KBD Locked Preempt	9 Call
18	9	Preempt	10 Call	19	9	KBD Locked Preempt	10 Call
18	10	TSP Check-Out	Detector 1	19	10	TSP Check-In	Detector 1
18	11	TSP Check-Out	Detector 2	19	11	TSP Check-In	Detector 2
18	12	TSP Check-Out	Detector 3	19	12	TSP Check In	Detector 3
18	13	TSP Check-Out	Detector 4	19	13	TSP Check In	Detector 4
18	14	TSP Check-Out	Detector 5	19	14	TSP Check In	Detector 5
18	15	TSP Check-Out	Detector 6	19	15	TSP Check In	Detector 6
20	0	Preempt	1 Gate Down	21	0	Preempt	1 Interlock
20	1	Preempt	2 Gate Down	21	1	Preempt	2 Interlock
20	2	Preempt	3 Gate Down	21	2	Preempt	3 Interlock
20	3	Preempt	4 Gate Down	21	3	Preempt	4 Interlock
20	4	Preempt	5 Gate Down	21	4	Preempt	5 Interlock
20	5	Preempt	6 Gate Down	21	5	Preempt	6 Interlock
20	6	Preempt	7 Gate Down	21	6	Preempt	7 Interlock
20	7	Preempt	8 Gate Down	21	7	Preempt	8 Interlock
20	8	Preempt	9 Gate Down	21	8	Preempt	9 Interlock
20	9	Preempt	10 Gate Down	21	9	Preempt	10 Interlock
20	10	Reserved (OFF)		21	10	TSP Advance	Detector 1
20	11	Not Assigned (OFF)		21	11	TSP Advance	Detector 2
20	12			21	12	TSP Advance	Detector 3
20	13			21	13	TSP Advance	Detector 4
20	14			21	14	TSP Advance	Detector 5
20	15			21	15	TSP Advance	Detector 6



Word /Bit	Bit Num	Input Signal	Description	Word /Bit	Bit Num	Input Signal	Description
22 0	352	Phase 1	Vehicle Call	23 0	368	Phase 1	Pedestrian Call
22 1	353	Phase 2	Vehicle Call	23 1	369	Phase 2	Pedestrian Call
22 2	354	Phase 3	Vehicle Call	23 2	370	Phase 3	Pedestrian Call
22 3	355	Phase 4	Vehicle Call	23 3	371	Phase 4	Pedestrian Call
22 4	356	Phase 5	Vehicle Call	23 4	372	Phase 5	Pedestrian Call
22 5	357	Phase 6	Vehicle Call	23 5	373	Phase 6	Pedestrian Call
22 6	358	Phase 7	Vehicle Call	23 6	374	Phase 7	Pedestrian Call
22 7	359	Phase 8	Vehicle Call	23 7	375	Phase 8	Pedestrian Call
22 8	360	Phase 9	Vehicle Call	23 8	376	Phase 9	Pedestrian Call
22 9	361	Phase 10	Vehicle Call	23 9	377	Phase 10	Pedestrian Call
22 10	362	Phase 11	Vehicle Call	23 10	378	Phase 11	Pedestrian Call
22 11	363	Phase 12	Vehicle Call	23 11	379	Phase 12	Pedestrian Call
22 12	364	Phase 13	Vehicle Call	23 12	380	Phase 13	Pedestrian Call
22 13	365	Phase 14	Vehicle Call	23 13	381	Phase 14	Pedestrian Call
22 14	366	Phase 15	Vehicle Call	23 14	382	Phase 15	Pedestrian Call
22 15	367	Phase 16	Vehicle Call	23 15	383	Phase 16	Pedestrian Call
24 0	384	Phase 1	Bike Call	25 0	400	Database CRC Bit 0	
24 1	385	Phase 2	Bike Call	25 1	401	Database CRC Bit 1	
24 2	386	Phase 3	Bike Call	25 2	402	Database CRC Bit 2	
24 3	387	Phase 4	Bike Call	25 3	403	Database CRC Bit 3	
24 4	388	Phase 5	Bike Call	25 4	404	Database CRC Bit 4	
24 5	389	Phase 6	Bike Call	25 5	405	Database CRC Bit 5	
24 6	390	Phase 7	Bike Call	25 6	406	Database CRC Bit 6	
24 7	391	Phase 8	Bike Call	25 7	407	Database CRC Bit 7	
24 8	392	Phase 9	Bike Call	25 8	408	Database CRC Bit 8	
24 9	393	Phase 10	Bike Call	25 9	409	Database CRC Bit 9	
24 10	394	Phase 11	Bike Call	25 10	410	Database CRC Bit 10	
24 11	395	Phase 12	Bike Call	25 11	411	Database CRC Bit 11	
24 12	396	Phase 13	Bike Call	25 12	412	Database CRC Bit 12	
24 13	397	Phase 14	Bike Call	25 13	413	Database CRC Bit 13	
24 14	398	Phase 15	Bike Call	25 14	414	Database CRC Bit 14	
24 15	399	Phase 16	Bike Call	25 15	415	Database CRC Bit 15	
26 0	416	Sequence A		27 0	432	Ped 2 Detector 1	
26 1	417	Sequence B		27 1	433	Ped 2 Detector 2	
26 2	418	Sequence C		27 2	434	Ped 2 Detector 3	
26 3	419	Sequence D		27 3	435	Ped 2 Detector 4	
26 4	420	Sequence E		27 4	436	Ped 2 Detector 5	
26 5	421	Timing Plan Bit A		27 5	437	Ped 2 Detector 6	
26 6	422	Timing Plan Bit B		27 6	438	Ped 2 Detector 7	
26 7	423	Timing Plan Bit C		27 7	439	Ped 2 Detector 8	
26 8	424	AUX switch input		27 8	440	Ped 2 Detector 9	
26 9	425			27 9	441	Ped 2 Detector 10	
26 10	426	Flash Sense Std (Standard)		27 10	442	Ped 2 Detector 11	
26 11	427	Flash Sense Mod		27 11	443	Ped 2 Detector 12	
26 12	428	Disable FYA Operation		27 12	444	Ped 2 Detector 13	
26 13	429	Early FYA		27 13	445	Ped 2 Detector 14	
26 14	430	Ignore STOP TIME in CRD		27 14	446	Ped 2 Detector 15	
26 15	431			27 15	447	Ped 2 Detector 16	

▪ Appendix S

Word /Bit	Bit Num	Input Signal	Description	Word /Bit	Bit Num	Input Signal	Description
28 0	448	Overlap A	Terminate Now	29 0	464	Overlap A	Omit
28 1	449	Overlap B	Terminate Now	29 1	465	Overlap B	Omit
28 2	450	Overlap C	Terminate Now	29 2	466	Overlap C	Omit
28 3	451	Overlap D	Terminate Now	29 3	467	Overlap D	Omit
28 4	452	Overlap E	Terminate Now	29 4	468	Overlap E	Omit
28 5	453	Overlap F	Terminate Now	29 5	469	Overlap F	Omit
28 6	454	Overlap G	Terminate Now	29 6	470	Overlap G	Omit
28 7	455	Overlap H	Terminate Now	29 7	471	Overlap H	Omit
28 8	456	Overlap I	Terminate Now	29 8	472	Overlap I	Omit
28 9	457	Overlap J	Terminate Now	29 9	473	Overlap J	Omit
28 10	458	Overlap K	Terminate Now	29 10	474	Overlap K	Omit
28 11	459	Overlap L	Terminate Now	29 11	475	Overlap L	Omit
28 12	460	Overlap M	Terminate Now	29 12	476	Overlap M	Omit
28 13	461	Overlap N	Terminate Now	29 13	477	Overlap N	Omit
28 14	462	Overlap O	Terminate Now	29 14	478	Overlap O	Omit
28 15	463	Overlap P	Terminate Now	29 15	479	Overlap P	Omit
30 0	480	Preempt 1	Low Priority Call	31 0	496	Veh Detector Plan Bit A	
30 1	481	Preempt 2	Low Priority Call	31 1	497	Veh Detector Plan Bit B	
30 2	482	Preempt 3	Low Priority Call	31 2	498	Veh Detector Plan Bit C	
30 3	483	Preempt 4	Low Priority Call	31 3	499		
30 4	484	Preempt 5	Low Priority Call	31 4	500		
30 5	485	Preempt 6	Low Priority Call	31 5	501		
30 6	486	Preempt 7	Low Priority Call	31 6	502	Veh Detector Diag Plan Bit A	
30 7	487	Preempt 8	Low Priority Call	31 7	503	Veh Detector Diag Plan Bit B	
30 8	488	Preempt 9	Low Priority Call	31 8	504	Veh Detector Diag Plan Bit C	
30 9	489	Preempt 10	Low Priority Call	31 9	505	Ped Detector Diag Plan Bit A	
30 10	490			31 10	506	Ped Detector Diag Plan Bit B	
30 11	491			31 11	507	Ped Detector Diag Plan Bit C	
30 12	492			31 12	508		
30 13	493			31 13	509		
30 14	494			31 14	510		
30 15	495			31 15	511		

Word /Bit	Bit Num	Input Signal	Description	Word /Bit	Bit Num	Input Signal	Description		
32	0	512	Ped Extend Detector	1	33	0	528	Red Extend Detector	1
32	1	513	Ped Extend Detector	2	33	1	529	Red Extend Detector	2
32	2	514	Ped Extend Detector	3	33	2	530	Red Extend Detector	3
32	3	515	Ped Extend Detector	4	33	3	531	Red Extend Detector	4
32	4	516	Ped Extend Detector	5	33	4	532	Red Extend Detector	5
32	5	517	Ped Extend Detector	6	33	5	533	Red Extend Detector	6
32	6	518	Ped Extend Detector	7	33	6	534	Red Extend Detector	7
32	7	519	Ped Extend Detector	8	33	7	535	Red Extend Detector	8
32	8	520	Ped Extend Detector	9	33	8	536	Red Extend Detector	9
32	9	521	Ped Extend Detector	10	33	9	537	Red Extend Detector	10
32	10	522	Ped Extend Detector	11	33	10	538	Red Extend Detector	11
32	11	523	Ped Extend Detector	12	33	11	539	Red Extend Detector	12
32	12	524	Ped Extend Detector	13	33	12	540	Red Extend Detector	13
32	13	525	Ped Extend Detector	14	33	13	541	Red Extend Detector	14
32	14	526	Ped Extend Detector	15	33	14	542	Red Extend Detector	15
32	15	527	Ped Extend Detector	16	33	15	543	Red Extend Detector	16
34	0	544	Ped 2 Call	1	35	0	560		
34	1	545	Ped 2 Call	2	35	1	561		
34	2	546	Ped 2 Call	3	35	2	562		
34	3	547	Ped 2 Call	4	35	3	563		
34	4	548	Ped 2 Call	5	35	4	564		
34	5	549	Ped 2 Call	6	35	5	565		
34	6	550	Ped 2 Call	7	35	6	566		
34	7	551	Ped 2 Call	8	35	7	567		
34	8	552	Ped 2 Call	9	35	8	568		
34	9	553	Ped 2 Call	10	35	9	569		
34	10	554	Ped 2 Call	11	35	10	570		
34	11	555	Ped 2 Call	12	35	11	571		
34	12	556	Ped 2 Call	13	35	12	572		
34	13	557	Ped 2 Call	14	35	13	573		
34	14	558	Ped 2 Call	15	35	14	574		
34	15	559	Ped 2 Call	16	35	15	575		

## Controller Output Buffer (COB)

Word /Bit	Bit Num	Output	Signal	Description	Word /Bit	Bit Num	Output	Signal	Description
0 0	0	Phase 1	Green	Green	1 0	16	Phase 1	Yellow	Yellow
0 1	1	Phase 2	Green	Green	1.1	17	Phase 2	Yellow	Yellow
0 2	2	Phase 3	Green	Green	1 2	18	Phase 3	Yellow	Yellow
0 3	3	Phase 4	Green	Green	1 3	19	Phase 4	Yellow	Yellow
0 4	4	Phase 5	Green	Green	1 4	20	Phase 5	Yellow	Yellow
0 5	5	Phase 6	Green	Green	1 5	21	Phase 6	Yellow	Yellow
0 6	6	Phase 7	Green	Green	1 6	22	Phase 7	Yellow	Yellow
0 7	7	Phase 8	Green	Green	1 7	23	Phase 8	Yellow	Yellow
0 8	8	Phase 9	Green	Green	1 8	24	Phase 9	Yellow	Yellow
0 9	9	Phase 10	Green	Green	1 9	25	Phase 10	Yellow	Yellow
0 10	10	Phase 11	Green	Green	1 10	26	Phase 11	Yellow	Yellow
0 11	11	Phase 12	Green	Green	1 11	27	Phase 12	Yellow	Yellow
0 12	12	Phase 13	Green	Green	1 12	28	Phase 13	Yellow	Yellow
0 13	13	Phase 14	Green	Green	1 13	29	Phase 14	Yellow	Yellow
0 14	14	Phase 15	Green	Green	1 14	30	Phase 15	Yellow	Yellow
0 15	15	Phase 16	Green	Green	1 15	31	Phase 16	Yellow	Yellow
2 0	32	Phase 1	Red	Red	3 0	48	Phase 1	Walk	Walk
2 1	33	Phase 2	Red	Red	3 1	49	Phase 2	Walk	Walk
2 2	34	Phase 3	Red	Red	3 2	50	Phase 3	Walk	Walk
2 3	35	Phase 4	Red	Red	3 3	51	Phase 4	Walk	Walk
2 4	36	Phase 5	Red	Red	3 4	52	Phase 5	Walk	Walk
2 5	37	Phase 6	Red	Red	3 5	53	Phase 6	Walk	Walk
2 6	38	Phase 7	Red	Red	3 6	54	Phase 7	Walk	Walk
2 7	39	Phase 8	Red	Red	3 7	55	Phase 8	Walk	Walk
2 8	40	Phase 9	Red	Red	3 8	56	Phase 9	Walk	Walk
2 9	41	Phase 10	Red	Red	3 9	57	Phase 10	Walk	Walk
2 10	42	Phase 11	Red	Red	3 10	58	Phase 11	Walk	Walk
2 11	43	Phase 12	Red	Red	3 11	59	Phase 12	Walk	Walk
2 12	44	Phase 13	Red	Red	3 12	60	Phase 13	Walk	Walk
2 13	45	Phase 14	Red	Red	3 13	61	Phase 14	Walk	Walk
2 14	46	Phase 15	Red	Red	3 14	62	Phase 15	Walk	Walk
2 15	47	Phase 16	Red	Red	3 15	63	Phase 16	Walk	Walk
4 0	64	Phase 1	Ped Clear	Ped Clear	5 0	80	Phase 1	Don't Walk	Don't Walk
4 1	65	Phase 2	Ped Clear	Ped Clear	5 1	81	Phase 2	Don't Walk	Don't Walk
4 2	66	Phase 3	Ped Clear	Ped Clear	5 2	82	Phase 3	Don't Walk	Don't Walk
4 3	67	Phase 4	Ped Clear	Ped Clear	5 3	83	Phase 4	Don't Walk	Don't Walk
4 4	68	Phase 5	Ped Clear	Ped Clear	5 4	84	Phase 5	Don't Walk	Don't Walk
4 5	69	Phase 6	Ped Clear	Ped Clear	5 5	85	Phase 6	Don't Walk	Don't Walk
4 6	70	Phase 7	Ped Clear	Ped Clear	5 6	86	Phase 7	Don't Walk	Don't Walk
4 7	71	Phase 8	Ped Clear	Ped Clear	5 7	87	Phase 8	Don't Walk	Don't Walk
4 8	72	Phase 9	Ped Clear	Ped Clear	5 8	88	Phase 9	Don't Walk	Don't Walk
4 9	73	Phase 10	Ped Clear	Ped Clear	5 9	89	Phase 10	Don't Walk	Don't Walk
4 10	74	Phase 11	Ped Clear	Ped Clear	5 10	90	Phase 11	Don't Walk	Don't Walk
4 11	75	Phase 12	Ped Clear	Ped Clear	5 11	91	Phase 12	Don't Walk	Don't Walk
4 12	76	Phase 13	Ped Clear	Ped Clear	5 12	92	Phase 13	Don't Walk	Don't Walk
4 13	77	Phase 14	Ped Clear	Ped Clear	5 13	93	Phase 14	Don't Walk	Don't Walk
4 14	78	Phase 15	Ped Clear	Ped Clear	5 14	94	Phase 15	Don't Walk	Don't Walk
4 15	79	Phase 16	Ped Clear	Ped Clear	5 15	95	Phase 16	Don't Walk	Don't Walk

Word /Bit	Bit Num	Output	Signal	Description	Word /Bit	Bit Num	Output	Signal	Description
6 0	96	Overlap	1	Green	7 0	112	Overlap	1	Yellow
6 1	97	Overlap	2	Green	7 1	113	Overlap	2	Yellow
6 2	98	Overlap	3	Green	7 2	114	Overlap	3	Yellow
6 3	99	Overlap	4	Green	7 3	115	Overlap	4	Yellow
6 4	100	Overlap	5	Green	7 4	116	Overlap	5	Yellow
6 5	101	Overlap	6	Green	7 5	117	Overlap	6	Yellow
6 6	102	Overlap	7	Green	7 6	118	Overlap	7	Yellow
6 7	103	Overlap	8	Green	7 7	119	Overlap	8	Yellow
6 8	104	Overlap	9	Green	7 8	120	Overlap	9	Yellow
6 9	105	Overlap	10	Green	7 9	121	Overlap	10	Yellow
6 10	106	Overlap	11	Green	7 10	122	Overlap	11	Yellow
6 11	107	Overlap	12	Green	7 11	123	Overlap	12	Yellow
6 12	108	Overlap	13	Green	7 12	124	Overlap	13	Yellow
6 13	109	Overlap	14	Green	7 13	125	Overlap	14	Yellow
6 14	110	Overlap	15	Green	7 14	126	Overlap	15	Yellow
6 15	111	Overlap	16	Green	7 15	127	Overlap	16	Yellow
8 0	128	Overlap	1	Red	9 0	144	CF24 Det Slots 1,2	Reset	
8 1	129	Overlap	2	Red	9 1	145	CF24 Det Slots 3,4	Reset	
8 2	130	Overlap	3	Red	9 2	146	CF24 Det Slots 5,6	Reset	
8 3	131	Overlap	4	Red	9 3	147	CF24 Det Slots 7,8	Reset	
8 4	132	Overlap	5	Red	9 4	148	CF25 Det Slots 1,2	Reset	
8 5	133	Overlap	6	Red	9 5	149	CF25 Det Slots 3,4	Reset	
8 6	134	Overlap	7	Red	9 6	150	CF25 Det Slots 5,6	Reset	
8 7	135	Overlap	8	Red	9 7	151	CF25 Det Slots 7,8	Reset	
8 8	136	Overlap	9	Red	9 8	152	CF26 Det Slots 1,2	Reset	
8 9	137	Overlap	10	Red	9 9	153	CF26 Det Slots 3,4	Reset	
8 10	138	Overlap	11	Red	9 10	154	CF26 Det Slots 5,6	Reset	
8 11	139	Overlap	12	Red	9 11	155	CF26 Det Slots 7,8	Reset	
8 12	140	Overlap	13	Red	9 12	156	CF27 Det Slots 1,2	Reset	
8 13	141	Overlap	14	Red	9 13	157	CF27 Det Slots 3,4	Reset	
8 14	142	Overlap	15	Red	9 14	158	CF27 Det Slots 5,6	Reset	
8 15	143	Overlap	16	Red	9 15	159	CF27 Det Slots 7,8	Reset	
10 0	160	LS	1	Green/Walk	11 0	176	LS	1	Yellow/PC
10 1	161	LS	2	Green/Walk	11 1	177	LS	2	Yellow/PC
10 2	162	LS	3	Green/Walk	11 2	178	LS	3	Yellow/PC
10 3	163	LS	4	Green/Walk	11 3	179	LS	4	Yellow/PC
10 4	164	LS	5	Green/Walk	11 4	180	LS	5	Yellow/PC
10 5	165	LS	6	Green/Walk	11 5	181	LS	6	Yellow/PC
10 6	166	LS	7	Green/Walk	11 6	182	LS	7	Yellow/PC
10 7	167	LS	8	Green/Walk	11 7	183	LS	8	Yellow/PC
10 8	168	LS	9	Green/Walk	11 8	184	LS	9	Yellow/PC
10 9	169	LS	10	Green/Walk	11 9	185	LS	10	Yellow/PC
10 10	170	LS	11	Green/Walk	11 10	186	LS	11	Yellow/PC
10 11	171	LS	12	Green/Walk	11 11	187	LS	12	Yellow/PC
10 12	172	LS	13	Green/Walk	11 12	188	LS	13	Yellow/PC
10 13	173	LS	14	Green/Walk	11 13	189	LS	14	Yellow/PC
10 14	174	LS	15	Green/Walk	11 14	190	LS	15	Yellow/PC
10 15	175	LS	16	Green/Walk	11 15	191	LS	16	Yellow/PC

▪ Appendix S

Word /Bit	Bit Num	Output	Signal	Description	Word /Bit	Bit Num	Output	Signal	Description
12 0	192	LS	1	Red/DW	13 0	208	LS	1	Green/Walk +
12 1	193	LS	2	Red/DW	13 1	209	LS	2	Green/Walk +
12 2	194	LS	3	Red/DW	13 2	210	LS	3	Green/Walk +
12 3	195	LS	4	Red/DW	13 3	211	LS	4	Green/Walk +
12 4	196	LS	5	Red/DW	13 4	212	LS	5	Green/Walk +
12 5	197	LS	6	Red/DW	13 5	213	LS	6	Green/Walk +
12 6	198	LS	7	Red/DW	13 6	214	LS	7	Green/Walk +
12 7	199	LS	8	Red/DW	13 7	215	LS	8	Green/Walk +
12 8	200	LS	9	Red/DW	13 8	216	LS	9	Green/Walk +
12 9	201	LS	10	Red/DW	13 9	217	LS	10	Green/Walk +
12 10	202	LS	11	Red/DW	13 10	218	LS	11	Green/Walk +
12 11	203	LS	12	Red/DW	13 11	219	LS	12	Green/Walk +
12 12	204	LS	13	Red/DW	13 12	220	LS	13	Green/Walk +
12 13	205	LS	14	Red/DW	13 13	221	LS	14	Green/Walk +
12 14	206	LS	15	Red/DW	13 14	222	LS	15	Green/Walk +
12 15	207	LS	16	Red/DW	13 15	223	LS	16	Green/Walk +
14 0	224	LS	1	Yellow/PC +	15 0	240	LS	1	Red/DW +
14 1	225	LS	2	Yellow/PC +	15 1	241	LS	2	Red/DW +
14 2	226	LS	3	Yellow/PC +	15 2	242	LS	3	Red/DW +
14 3	227	LS	4	Yellow/PC +	15 3	243	LS	4	Red/DW +
14 4	228	LS	5	Yellow/PC +	15 4	244	LS	5	Red/DW +
14 5	229	LS	6	Yellow/PC +	15 5	245	LS	6	Red/DW +
14 6	230	LS	7	Yellow/PC +	15 6	246	LS	7	Red/DW +
14 7	231	LS	8	Yellow/PC +	15 7	247	LS	8	Red/DW +
14 8	232	LS	9	Yellow/PC +	15 8	248	LS	9	Red/DW +
14 9	233	LS	10	Yellow/PC +	15 9	249	LS	10	Red/DW +
14 10	234	LS	11	Yellow/PC +	15 10	250	LS	11	Red/DW +
14 11	235	LS	12	Yellow/PC +	15 11	251	LS	12	Red/DW +
14 12	236	LS	13	Yellow/PC +	15 12	252	LS	13	Red/DW +
14 13	237	LS	14	Yellow/PC +	15 13	253	LS	14	Red/DW +
14 14	238	LS	15	Yellow/PC +	15 14	254	LS	15	Red/DW +
14 15	239	LS	16	Yellow/PC +	15 15	255	LS	16	Red/DW +
16 0	256	LS	1	Green/Walk -	17 0	272	LS	1	Yellow/PC -
16 1	257	LS	2	Green/Walk -	17 1	273	LS	2	Yellow/PC -
16 2	258	LS	3	Green/Walk -	17 2	274	LS	3	Yellow/PC -
16 3	259	LS	4	Green/Walk -	17 3	275	LS	4	Yellow/PC -
16 4	260	LS	5	Green/Walk -	17 4	276	LS	5	Yellow/PC -
16 5	261	LS	6	Green/Walk -	17 5	277	LS	6	Yellow/PC -
16 6	262	LS	7	Green/Walk -	17 6	278	LS	7	Yellow/PC -
16 7	263	LS	8	Green/Walk -	17 7	279	LS	8	Yellow/PC -
16 8	264	LS	9	Green/Walk -	17 8	280	LS	9	Yellow/PC -
16 9	265	LS	10	Green/Walk -	17 9	281	LS	10	Yellow/PC -
16 10	266	LS	11	Green/Walk -	17 10	282	LS	11	Yellow/PC -
16 11	267	LS	12	Green/Walk -	17 11	283	LS	12	Yellow/PC -
16 12	268	LS	13	Green/Walk -	17 12	284	LS	13	Yellow/PC -
16 13	269	LS	14	Green/Walk -	17 13	285	LS	14	Yellow/PC -
16 14	270	LS	15	Green/Walk -	17 14	286	LS	15	Yellow/PC -
16 15	271	LS	16	Green/Walk -	17 15	287	LS	16	Yellow/PC -

Word /Bit	Bit Num	Output	Signal	Description	Word /Bit	Bit Num	Output	Signal	Description
18 0	288	LS	1	Red/DW -	19 0	304	Phase	1	Detector Fail
18 1	289	LS	2	Red/DW -	19 1	305	Phase	2	Detector Fail
18 2	290	LS	3	Red/DW -	19 2	306	Phase	3	Detector Fail
18 3	291	LS	4	Red/DW -	19 3	307	Phase	4	Detector Fail
18 4	292	LS	5	Red/DW -	19 4	308	Phase	5	Detector Fail
18 5	293	LS	6	Red/DW -	19 5	309	Phase	6	Detector Fail
18 6	294	LS	7	Red/DW -	19 6	310	Phase	7	Detector Fail
18 7	295	LS	8	Red/DW -	19 7	311	Phase	8	Detector Fail
18 8	296	LS	9	Red/DW -	19 8	312	Phase	9	Detector Fail
18 9	297	LS	10	Red/DW -	19 9	313	Phase	10	Detector Fail
18 10	298	LS	11	Red/DW -	19 10	314	Phase	11	Detector Fail
18 11	299	LS	12	Red/DW -	19 11	315	Phase	12	Detector Fail
18 12	300	LS	13	Red/DW -	19 12	316	Phase	13	Detector Fail
18 13	301	LS	14	Red/DW -	19 13	317	Phase	14	Detector Fail
18 14	302	LS	15	Red/DW -	19 14	318	Phase	15	Detector Fail
18 15	303	LS	16	Red/DW -	19 15	319	Phase	16	Detector Fail
20 0	320	Phase	1	Timing	21 0	336	Phase	1	Next
20 1	321	Phase	2	Timing	21 1	337	Phase	2	Next
20 2	322	Phase	3	Timing	21 2	338	Phase	3	Next
20 3	323	Phase	4	Timing	21 3	339	Phase	4	Next
20 4	324	Phase	5	Timing	21 4	340	Phase	5	Next
20 5	325	Phase	6	Timing	21 5	341	Phase	6	Next
20 6	326	Phase	7	Timing	21 6	342	Phase	7	Next
20 7	327	Phase	8	Timing	21 7	343	Phase	8	Next
20 8	328	Phase	9	Timing	21 8	344	Phase	9	Next
20 9	329	Phase	10	Timing	21 9	345	Phase	10	Next
20 10	330	Phase	11	Timing	21 10	346	Phase	11	Next
20 11	331	Phase	12	Timing	21 11	347	Phase	12	Next
20 12	332	Phase	13	Timing	21 12	348	Phase	13	Next
20 13	333	Phase	14	Timing	21 13	349	Phase	14	Next
20 14	334	Phase	15	Timing	21 14	350	Phase	15	Next
20 15	335	Phase	16	Timing	21 15	351	Phase	16	Next
22 0	352	Phase	1	Vehicle Check	23 0	368	Phase	1	Pedestrian Check
22 1	353	Phase	2	Vehicle Check	23 1	369	Phase	2	Pedestrian Check
22 2	354	Phase	3	Vehicle Check	23 2	370	Phase	3	Pedestrian Check
22 3	355	Phase	4	Vehicle Check	23 3	371	Phase	4	Pedestrian Check
22 4	356	Phase	5	Vehicle Check	23 4	372	Phase	5	Pedestrian Check
22 5	357	Phase	6	Vehicle Check	23 5	373	Phase	6	Pedestrian Check
22 6	358	Phase	7	Vehicle Check	23 6	374	Phase	7	Pedestrian Check
22 7	359	Phase	8	Vehicle Check	23 7	375	Phase	8	Pedestrian Check
22 8	360	Phase	9	Vehicle Check	23 8	376	Phase	9	Pedestrian Check
22 9	361	Phase	10	Vehicle Check	23 9	377	Phase	10	Pedestrian Check
22 10	362	Phase	11	Vehicle Check	23 10	378	Phase	11	Pedestrian Check
22 11	363	Phase	12	Vehicle Check	23 11	379	Phase	12	Pedestrian Check
22 12	364	Phase	13	Vehicle Check	23 12	380	Phase	13	Pedestrian Check
22 13	365	Phase	14	Vehicle Check	23 13	381	Phase	14	Pedestrian Check
22 14	366	Phase	15	Vehicle Check	23 14	382	Phase	15	Pedestrian Check
22 15	367	Phase	16	Vehicle Check	23 15	383	Phase	16	Pedestrian Check

▪ Appendix S

Word /Bit	Bit Num	Output Signal Description	Word /Bit	Bit Num	Output Signal Description
24 0	384	NEMA Status Bit A (R1)	25 0	400	NEMA Status Bit A (R3)
24 1	385	NEMA Status Bit B (R1)	25 1	401	NEMA Status Bit B (R3)
24 2	386	NEMA Status Bit C (R1)	25 2	402	NEMA Status Bit C (R3)
24 3	387	Coord Direction (R1)	25 3	403	Coord Direction (R3)
24 4	388		25 4	404	
24 5	389		25 5	405	
24 6	390		25 6	406	
24 7	391		25 7	407	
24 8	392	NEMA Status Bit A (R2)	25 8	408	NEMA Status Bit A (R4)
24 9	393	NEMA Status Bit B (R2)	25 9	409	NEMA Status Bit B (R4)
24 10	394	NEMA Status Bit C (R2)	25 10	410	NEMA Status Bit C (R4)
24 11	395	Coord Direction (R2)	25 11	411	Coord Direction (R4)
24 12	396		25 12	412	
24 13	397		25 13	413	
24 14	398		25 14	414	
24 15	399		25 15	415	
26 0	416	Preemptor 1 Status	27 0	432	Cycle Bit 1 / TP Bit A
26 1	417	Preemptor 2 Status	27 1	433	Cycle Bit 2 / TP Bit B
26 2	418	Preemptor 3 Status	27 2	434	Cycle Bit 3
26 3	419	Preemptor 4 Status	27 3	435	Offset Bit 1
26 4	420	Preemptor 5 Status	27 4	436	Offset Bit 2
26 5	421	Preemptor 6 Status	27 5	437	Offset Bit 3
26 6	422	Preemptor 7 Status	27 6	438	Split Bit 1 / TP Bit C
26 7	423	Preemptor 8 Status	27 7	439	Split Bit 2 / TP Bit D
26 8	424	Preemptor 9 Status	27 8	440	
26 9	425	Preemptor 10 Status	27 9	441	
26 10	426		27 10	442	
26 11	427		27 11	443	
26 12	428		27 12	444	
26 13	429	Preemptor Flash	27 13	445	
26 14	430	FALSE (always logical 0)	27 14	446	
26 15	431	TRUE (always logical 1)	27 15	447	
28 0	448		29 0	464	
28 1	449		29 1	465	
28 2	450	Crd Alarm	29 2	466	
28 3	451	Crd Error	29 3	467	
28 4	452	Crd Sync Out	29 4	468	
28 5	453	Crd X Street Sync Out	29 5	469	
28 6	454	Crd Free Status	29 6	470	
28 7	455	Crd No Fault Flash	29 7	471	
28 8	456		29 8	472	
28 9	457		29 9	473	
28 10	458		29 10	474	
28 11	459		29 11	475	
28 12	460		29 12	476	
28 13	461		29 13	477	
28 14	462		29 14	478	
28 15	463		29 15	479	



Word /Bit	Bit Num	Output Signal Description	Word /Bit	Bit Num	Output Signal Description
30 0	480		31 0	496	
30 1	481		31 1	497	
30 2	482		31 2	498	
30 3	483		31 3	499	
30 4	484		31 4	500	
30 5	485		31 5	501	
30 6	486		31 6	502	
30 7	487		31 7	503	
30 8	488		31 8	504	
30 9	489		31 9	505	
30 10	490		31 10	506	
30 11	491		31 11	507	
30 12	492		31 12	508	
30 13	493		31 13	509	
30 14	494		31 14	510	
30 15	495		31 15	511	
32 0	512	TOD Special Function 1	33 0	528	Auxiliary 1
32 1	513	TOD Special Function 2	33 1	529	Auxiliary 2
32 2	514	TOD Special Function 3	33 2	530	Auxiliary 3
32 3	515	TOD Special Function 4	33 3	531	
32 4	516	TOD Special Function 5	33 4	532	
32 5	517	TOD Special Function 6	33 5	533	
32 6	518	TOD Special Function 7	33 6	534	
32 7	519	TOD Special Function 8	33 7	535	
32 8	520	TLM Special Function 1	33 8	536	Address Bit 0
32 9	521	TLM Special Function 2	33 9	537	Address Bit 1
32 10	522	TLM Special Function 3	33 10	538	Address Bit 2
32 11	523	TLM Special Function 4	33 11	539	Address Bit 3
32 12	524	TLM Special Function 5	33 12	540	Address Bit 4
32 13	525	TLM Special Function 6	33 13	541	
32 14	526	TLM Special Function 7	33 14	542	Voltage Monitor
32 15	527	TLM Special Function 8	33 15	543	Fault Monitor
34 0	544	Automatic (Remote) Flash	35 0	560	Coord Special Function 1
34 1	545	Preempt CMU Interlock	35 1	561	Coord Special Function 2
34 2	546	Flashing Logic 1 Hz	35 2	562	Coord Special Function 3
34 3	547	Flashing Logic 1.67 Hz	35 3	563	Coord Special Function 4
34 4	548	Flashing Logic 5 Hz	35 4	564	Coord Special Function 5
34 5	549	Flashing Logic 6.25 Hz	35 5	565	Coord Special Function 6
34 6	550	Local Flash Status	35 6	566	Coord Special Function 7
34 7	551	MMU Flash Status	35 7	567	Coord Special Function 8
34 8	552	No Fault Flash Status	35 8	568	Preempt Special Function 1
34 9	553	WDOG	35 9	569	Preempt Special Function 2
34 10	554	TSP 1 Active Status	35 10	570	Preempt Special Function 3
34 11	555	TSP 2 Active Status	35 11	571	Preempt Special Function 4
34 12	556	TSP 3 Active Status	35 12	572	Preempt Special Function 5
34 13	557	TSP 4 Active Status	35 13	573	Preempt Special Function 6
34 14	558	TSP 5 Active Status	35 14	574	Preempt Special Function 7
34 15	559	TSP 6 Active Status	35 15	575	Preempt Special Function 8

▪ Appendix S

Word /Bit	Bit Num	Output Signal Description	Word /Bit	Bit Num	Output Signal Description
36 0	576		37 0	592	
36 1	577		37 1	593	
36 2	578		37 2	594	
36 3	579		37 3	595	
36 4	580		37 4	596	
36 5	581		37 5	597	
36 6	582		37 6	598	
36 7	583		37 7	599	
36 8	584		37 8	600	
36 9	585		37 9	601	
36 10	586		37 10	602	
36 11	587		37 11	603	
36 12	588		37 12	604	
36 13	589		37 13	605	
36 14	590		37 14	606	
36 15	591		37 15	607	
38 0	608		39 0	624	
38 1	609		39 1	625	
38 2	610		39 2	626	
38 3	611		39 3	627	
38 4	612		39 4	628	
38 5	613		39 5	629	
38 6	614		39 6	630	
38 7	615		39 7	631	
38 8	616		39 8	632	
38 9	617		39 9	633	
38 10	618		39 10	634	
38 11	619		39 11	635	
38 12	620		39 12	636	
38 13	621		39 13	637	
38 14	622		39 14	638	
38 15	623		39 15	639	
40 0	640		41 0	656	
40 1	641		41 1	657	
40 2	642		41 2	658	
40 3	643		41 3	659	
40 4	644		41 4	660	
40 5	645		41 5	661	
40 6	646		41 6	662	
40 7	647		41 7	663	
40 8	648		41 8	664	
40 9	649		41 9	665	
40 10	650		41 10	666	
40 11	651		41 11	667	
40 12	652		41 12	668	
40 13	653		41 13	669	
40 14	654		41 14	670	
40 15	655		41 15	671	

Word /Bit	Bit Num	Output Signal	Description	Word /Bit	Bit Num	Output Signal	Description
42 0	672	Preempt 1	Status Bit A	43 0	688	Preempt 4	Status Bit A
42 1	673	Preempt 1	Status Bit B	43 1	689	Preempt 4	Status Bit B
42 2	674	Preempt 1	Status Bit C	43 2	690	Preempt 4	Status Bit C
42 3	675	Preempt 1	Status Bit D	43 3	691	Preempt 4	Status Bit D
42 4	676	Preempt 1	Status Bit E	43 4	692	Preempt 4	Status Bit E
42 5	677	Preempt 2	Status Bit A	43 5	693	Preempt 5	Status Bit A
42 6	678	Preempt 2	Status Bit B	43 6	694	Preempt 5	Status Bit B
42 7	679	Preempt 2	Status Bit C	43 7	695	Preempt 5	Status Bit C
42 8	680	Preempt 2	Status Bit D	43 8	696	Preempt 5	Status Bit D
42 9	681	Preempt 2	Status Bit E	43 9	697	Preempt 5	Status Bit E
42 10	682	Preempt 3	Status Bit A	43 10	698	Preempt 6	Status Bit A
42 11	683	Preempt 3	Status Bit B	43 11	699	Preempt 6	Status Bit B
42 12	684	Preempt 3	Status Bit C	43 12	700	Preempt 6	Status Bit C
42 13	685	Preempt 3	Status Bit D	43 13	701	Preempt 6	Status Bit D
42 14	686	Preempt 3	Status Bit E	43 14	702	Preempt 6	Status Bit E
42 15	687			43 15	703		
44 0	704	Preempt 7	Status Bit A	45 0	720	Preempt 10	Status Bit A
44 1	705	Preempt 7	Status Bit B	45 1	721	Preempt 10	Status Bit B
44 2	706	Preempt 7	Status Bit C	45 2	722	Preempt 10	Status Bit C
44 3	707	Preempt 7	Status Bit D	45 3	723	Preempt 10	Status Bit D
44 4	708	Preempt 7	Status Bit E	45 4	724	Preempt 10	Status Bit E
44 5	709	Preempt 8	Status Bit A	45 5	725		
44 6	710	Preempt 8	Status Bit B	45 6	726		
44 7	711	Preempt 8	Status Bit C	45 7	727		
44 8	712	Preempt 8	Status Bit D	45 8	728		
44 9	713	Preempt 8	Status Bit E	45 9	729		
44 10	714	Preempt 9	Status Bit A	45 10	730		
44 11	715	Preempt 9	Status Bit B	45 11	731		
44 12	716	Preempt 9	Status Bit C	45 12	732		
44 13	717	Preempt 9	Status Bit D	45 13	733		
44 14	718	Preempt 9	Status Bit E	45 14	734		
44 15	719			45 15	735		
46 0	736			47 0	752		
46 1	737			47 1	753		
46 2	738			47 2	754		
46 3	739			47 3	755		
46 4	740			47 4	756		
46 5	741			47 5	757		
46 6	742			47 6	758		
46 7	743			47 7	759		
46 8	744			47 8	760		
46 9	745			47 9	761		
46 10	746			47 10	762		
46 11	747			47 11	763		
46 12	748			47 12	764		
46 13	749			47 13	765		
46 14	750			47 14	766		
46 15	751			47 15	767		

---

**For your notes:**



---

# Glossary

## Introduction

There are three tables in this glossary of controller-related terms:

- Acronyms, on this page.
- Controller terms, [page T-2](#).
- Abbreviations of Connector Pin Functions, [page T-14](#).

For Abbreviations in Flash Status Messages, refer to [page 12-69](#).

## Acronyms

Acronym	Meaning
AC	Alternating Current
BIU	Bus Interface Unit
CA	Controller Assembly
CU	Controller Unit
EPROM	Erasable Programmable Read Only Memory
FEPRM	Flash Programmable Read Only Memory
ITS	Intelligent Transportation Systems
MMU	Malfunction Management Unit
NEMA	National Electrical Manufacturers Association
NTCIP	National Transportation Communication for ITS Protocol
PROM	Programmable Read Only Memory
RAM	Random Access Memory

## Glossary

▪ *Appendix T*

Acronym	Meaning
ROM	Read Only Memory
SDLC	Synchronous Data Link Control
TF	Terminals and Facilities
TSP	Transit Signal Priority

### Controller Terms

Term	Meaning
Auxiliary Equipment	Separate devices used to add supplementary features to a controller assembly.
Barrier	A barrier (compatibility line) is a reference point in the preferred sequence of a multi-ring CU at which all rings are interlocked. Barriers assure there will be no concurrent selection and timing of conflicting phases for traffic movements in different rings. All rings cross the barrier operate simultaneously to select and time phases on the other side.
BIU	<b>Bus Interface Unit.</b> A module used to interface the controller with the field terminals and detector loops in a TS2 cabinet.
Cabinet	An outdoor enclosure for housing the controller unit and associated equipment.
Call	A registration of a demand for right-of-way by traffic (vehicles or pedestrians) to a controller unit. Serviceable Conflicting call: <ul style="list-style-type: none"><li>■ Occurs on a conflicting phase not having the right-of-way at the time the call is placed.</li><li>■ Occurs on a conflicting phase, which is capable of responding to a call.</li><li>■ When occurring on a conflicting phase operating in an occupancy mode, remains present until given its right-of-way.</li></ul>
Check	An output from a controller unit that indicates the existence of an unanswered call(s).

Term	Meaning
Connector	<p>A device enabling outgoing and incoming electrical circuits to be connected and disconnected without the necessity of installing and removing individual wires leading from the control unit.</p> <p><b>Not Used Connections</b> - The "Not Used" connector pin termination(s) are used exclusively to prevent interchangeability with units already in use not in conformance to this publication. These connector pins are not to be internally connected.</p> <p><b>Reserved Connections</b> - The "Reserved" connector pin termination are used exclusively for future assignment by NEMA of additional specific input/output functions. The control unit does not recognize any "reserved" input as valid nor shall it provide a valid output on a "Reserved" output.</p> <p><b>Spare Connections</b> - The "Spare" connector pin terminations are exclusively for manufacturer specific applications. A controller Assembly wired to utilize one of these connections may not be compatible with all manufacturer's control units.</p>
Controller Assembly	<p>A complete electrical device mounted in a cabinet for controlling the operation of a traffic control signal.</p> <ul style="list-style-type: none"> <li>■ <b>Flasher Controller Assembly</b> - A complete electrical device for flashing a traffic signal or beacon.</li> <li>■ <b>Full-Traffic-Actuated Controller Assembly</b> - A type of traffic-actuated controller assembly in which means are provided for traffic actuation on all approaches to the intersection.</li> <li>■ <b>Isolated Controller Assembly</b> - A controller assembly for operating traffic signals not under master supervision.</li> <li>■ <b>Master Controller Assembly</b> - A controller assembly for supervising a system of secondary controller assemblies.</li> <li>■ <b>Master-Secondary Controller Assembly</b> - A controller assembly operating traffic signals and providing supervision of other secondary controller assemblies.</li> <li>■ <b>Occupancy Controller Assembly (Lane-Occupancy Controller or Demand Controller, and Presence Controller)</b> - A traffic-actuated controller which responds to the presence of vehicles within an extended zone of detection.</li> </ul>

Term	Meaning
Controller Assembly (continued)	<ul style="list-style-type: none"> <li>■ <b>Pedestrian-Actuated Controller Assembly</b> - A controller assembly in which intervals, such as pedestrian Walk and clearance intervals, can be added to or included in the controller cycle by the actuation of a pedestrian detector.</li> <li>■ <b>Pretimed Controller Assembly</b> - A controller assembly for the operation of traffic signals with predetermined:               <ul style="list-style-type: none"> <li>• Fixed cycle length(s).</li> <li>• Fixed interval duration(s).</li> <li>• Interval sequence(s).</li> </ul> </li> <li>■ <b>Secondary Controller Assembly (slave)</b> - A controller assembly which operates traffic signals under the supervision of a master controller assembly.</li> <li>■ <b>Semi-Traffic Actuated Controller Assembly</b> - A type of traffic-actuated controller assembly in which means are provided for traffic actuation on one or more but not all approaches to the intersection.</li> <li>■ <b>Traffic-Actuated Controller Assembly</b> - A controller assembly for supervising the operation of traffic control signals in accordance with the varying demands of traffic as registered with the controller by detectors.</li> </ul>
Controller Unit	<p>A controller unit is that portion of a controller assembly that is devoted to the selection and timing of signal displays.</p> <p><b>Digital Controller Unit</b> - A controller unit wherein timing is based upon a defined frequency source such as a 60-hertz alternating current source.</p> <p><b>Multi-ring Controller Unit</b> - A multi-ring CU contains two or more interlocked rings which are arranged to time in a preferred sequence and to allow concurrent timing of all rings, subject to the restraint on Barrier.</p> <p><b>Single-Ring Controller Unit</b> - A single-ring CU contains two or more sequentially-timed and individually-selected conflicting phases so arranged as to occur in an established order.</p>
Concentration	<p>The largest of Scaled Occupancy or Scaled Volume expressed in percent.</p>



Term	Meaning
Coordination	The control of controller units in a manner to provide a relationship between specific green indications at adjacent intersections in accordance with a time schedule to permit continuous operation of groups of vehicles along the street at a planned speed.
Coordinator	A device, program or routine which provides coordination.
Cycle	The total time to complete one sequence of signalization around an intersection. In an actuated CU, a complete cycle is dependent on the presence of calls on all phases. In a pretimed CU unit it is a complete sequence of signal indications.
Cycle Length	The time period in seconds required for one complete cycle.
Density	A measure of the concentration of vehicles, stated as the number of vehicles per mile per lane.
Detection	<p><b>Advisory Detection</b> - The detection of vehicles on one or more intersection approaches solely for the purpose of modifying the phase sequence and/or length for other approaches to the intersection.</p> <p><b>Passage Detection</b> - The ability of a vehicle detector to detect the passage of a vehicle moving through the zone of detection and to ignore the presence of a vehicle stopped within the zone of detection.</p> <p><b>Presence Detection</b> - The ability of a vehicle detector to sense that a vehicle, whether moving or stopped, has appeared in its zone of detection.</p> <p><b>Zone of Detection</b> - The area or zone that a vehicle detector can detect a vehicle.</p>
Detector	<p>A device for indicating the presence or passage of vehicles or pedestrians.</p> <p><b>Bi-directional Detector</b> - A detector that is capable of being actuated by vehicles proceeding in either of two directions and of indicating in which of the directions the vehicles were moving.</p> <p><b>Calling Detector</b> - A registration of a demand during red interval for right-of-way by traffic (vehicles or pedestrians) to a controller unit.</p> <p><b>Classification Detector</b> - A detector that has the capability of differentiating among types of vehicles.</p>

Term	Meaning
Detector (continued)	<p><b>Directional Detector</b> - A detector that is capable of being actuated only by vehicles proceeding in one specified direction.</p> <p><b>Extension Detector</b> - A detector that is arranged to register an actuation at the controller unit only during the green interval for that approach so as to extend the green time of the actuating vehicles.</p> <p><b>Infrared Detector</b> - A detector that senses radiation in the infrared spectrum.</p> <p><b>Light-Sensitive Detector</b> - A detector that utilizes a light-sensitive device for sensing the passage of an object interrupting a beam of light directed at the sensor.</p> <p><b>Loop Detector</b> - A detector that senses a change in inductance of its inductive loop sensor by the passage or presence of a vehicle near the sensor.</p> <p><b>Magnetic Detector</b> - A detector that senses changes in the earth's magnetic field caused by the movement of a vehicle near its sensor.</p> <p><b>Magnetometer Detector</b> - A detector that measures the difference in the level of the earth's magnetic forces caused by the passage or presence of a vehicle near its sensor.</p> <p><b>Nondirectional Detector</b> - A detector that is capable of being actuated by vehicles proceeding in any direction.</p> <p><b>Pedestrian Detector</b> - A detector that is responsive to operation by or the presence of a pedestrian.</p> <p><b>Pneumatic Detector</b> - A pressure-sensitive detector that uses a pneumatic tube as a sensor.</p> <p><b>Pressure-Sensitive Detector</b> - A detector that is capable of sensing the pressure of a vehicle passing over the surface of its sensor.</p> <p><b>Radar Detector</b> - A detector that is capable of sensing the passage of a vehicle through its field of emitted microwave energy.</p> <p><b>System Detector</b> - Any type of vehicle detector used to obtain representative traffic flow information.</p> <p><b>Side-Fire Detector</b> - A vehicle detector with its sensor located to one side of the roadway.</p>

Term	Meaning
Detector (continued)	<p><b>Sound-Sensitive Vehicle Detector</b> - A detector that responds to sound waves generated by the passage of a vehicle near the surface of the sensor.</p> <p><b>Ultrasonic Detector</b> - A detector that is capable of sensing the passage or presence of a vehicle through its field of emitted ultrasonic energy.</p> <p><b>Video Detection</b> - A detector that responds the Video image or changes in the Video image of a vehicle.</p>
Detector Mode	<p>A term used to describe the operation of a detector channel output when a presence detection occurs.</p> <p><b>Pulse Mode</b> - Detector produces a short output pulse when detection occurs.</p> <p><b>Controlled Output</b> - The ability of a detector to produce a pulse that has a predetermined duration regardless of the length of time a vehicle is in the zone of detection.</p> <p><b>Continuous-Presence Mode</b> - Detector output continues if any vehicle (first or last remaining) remains in the zone of detection.</p> <p><b>Limited-Presence Mode</b> - Detector output continues for a limited period of time if vehicles remain in zone of detection.</p>
Device	<p><b>Electromechanical Device</b> - A device which is characterized by electrical circuits utilizing relays, step switches, motors, etc.</p> <p><b>Electronic Device</b> - A device which is characterized by electrical circuits utilizing vacuum tubes, resistors, capacitors, inductors and which may include electromechanical and solid state devices.</p> <p><b>Solid State Device</b> - A device which is characterized by electrical circuits, the active components of which are semi-conductors, to the exclusion of electromechanical devices or tubes.</p>
Dial	<p>The cycle timing reference or coordination input activating same. Dial is also frequently used to describe the cycle.</p>
Dwell	<p>The interval portion of a phase when present timing requirements have been completed.</p>

Term	Meaning
Entry	<p><b>Dual Entry</b> - Dual entry is a mode of operation (in a multi-ring CU) in which one phase in each ring must be in service. If a call does not exist in a ring when it crosses the barrier, a phase is selected in that ring to be activated by the CU in a predetermined manner.</p> <p><b>Single Entry</b> - Single entry mode of operation (in multi-ring CU) in which a phase in one ring can be selected and timed alone if there is no demand for service in a nonconflicting phase on parallel ring(s).</p>
Extension Unit	The timing interval during the extensible portion which is resettable by each detector actuation. The green interval of the phase may terminate on expiration of the unit extension time.
Flasher	A device used to open and close signal circuits at a repetitive rate.
Force Off	A command to force the termination of the Green extension in actuated mode or Walk Hold in the nonactuated mode of the active phase. Termination is subject to presence of a serviceable conflicting call.
Gap Reduction	A feature whereby the "unit extension" or allowed time spacing between successive vehicle actuation(s) on the phase displaying the green in the extensible portion of the interval is reduced.
Hold	A command that retains the existing Green interval.
Interconnect	A means of remotely controlling some or all of the functions of a traffic signal.
Interval	<p>The parts of the signal cycle during which signal indications do not change.</p> <p><b>Minimum Green Interval</b> - The shortest green time of a phase. If a time setting control is designated as "minimum green," the green time shall be not less than that setting.</p> <p><b>Pedestrian Clearance Interval</b> - The first clearance interval for the pedestrian signal following the pedestrian Walk indication.</p> <p><b>Red Clearance Interval</b> - A clearance interval which may follow the yellow change interval during which both the terminating phase and the next phase display Red signal indications.</p> <p><b>Sequence, Interval</b> - The order of appearance of signal indications during successive intervals of a cycle.</p>

Term	Meaning
Interval (continued)	<b>Yellow Change Interval</b> - The first interval following the green interval in which the signal indication for that phase is yellow.
Manual	<p><b>Manual Operation</b> - The operation of a controller assembly by means of a hand-operated device(s). A push-button is an example of such a device.</p> <p><b>Manual Push-button</b> - An auxiliary device for hand operation of a controller assembly.</p>
Maximum Green	The maximum green time with a serviceable opposing actuation, which may start during the initial portion.
Memory	<p><b>Detector Memory</b> - The retention of a call for future utilization by the controller assembly.</p> <p><b>EPROM</b> - Read-Only, non-volatile, semiconductor memory that is erasable (via ultra-violet light) and reprogrammable.</p> <p><b>FEPRM</b> - Read-Only, non-volatile, semiconductor memory that is electrical erasable reprogrammable.</p> <p><b>Nonlocking Memory</b> - A mode of actuated-controller-unit operation which does not require detector memory.</p> <p><b>Non-Volatile Memory</b> - Read/Write memory that is capable of data retention during periods when AC power is not applied for a minimum period of 30 days.</p> <p><b>PROM</b> - Read-Only, non-volatile, semiconductor memory that allows a program to reside permanently in a piece of hardware.</p> <p><b>RAM</b> - Semiconductor Read/Write volatile memory. Data is lost if power is turned off.</p> <p><b>ROM</b> - Read-Only, non-volatile, semiconductor memory manufactured with data content, permanently stored.</p> <p><b>Volatile Memory</b> - Read/Write memory that loses data when power is removed.</p>
MMU	<b>Malfunction Management Unit</b> - A device used to detect and respond to improper and conflicting signals and improper operating voltages in a traffic control system.
Modular Design	A device concept such that functions are sectioned into units which can be readily exchanged with similar units.
NTCIP	National Transportation Communication for ITS Protocol

Term	Meaning
Occupancy	<p><b>Actual</b> - The percent of time that vehicles passing a point occupy the roadway during a period in time. Typically expressed in Percent of occupied per Hour or Vehicles per Hour per Lane.</p> <p><b>Scaled</b> - The percentage that the Actual Occupancy when compared to a stated maximum. The stated maximum is considered to be 100% use of the roadway.</p>
Offset	Offset is the time relationship, expressed in seconds or percent of cycle length, determined by the difference between a defined point in the coordinated green and a system reference point.
Omit Phase (Special Skip, Force Skip)	A command that causes omission of a selected phase.
Overlap	A Green indication that allows traffic movement during the green intervals of and clearance intervals between two or more phases.
Passage Time	The time allowed for a vehicle to travel at a selected speed from the detector to the stop line.
Pattern	A unique set of coordination parameters (cycle, value, split values, offset value, and sequence).
Phase	<p><b>Conflicting Phases</b> - Conflicting phases are two or more traffic phases which will cause interfering traffic movements if operated concurrently.</p> <p><b>Interrupted Phases</b> - Timing when the preemptor tries to start.</p> <p><b>Nonconflicting Phase</b> - Nonconflicting phases are two or more traffic phases which will not cause interfering traffic movements if operated concurrently.</p> <p><b>Parent Phase</b> - A traffic phase with which a subordinate phase is associated.</p> <p><b>Pedestrian Phase</b> - A traffic phase allocated to pedestrian traffic which may provide a right-of-way pedestrian indication either concurrently with one or more vehicular phases, or to the exclusion of all vehicular phases.</p> <p><b>Phase Sequence</b> - A predetermined order in which the phases of a cycle occur.</p> <p><b>Traffic Phase</b> - Those green, change and clearance intervals in a cycle assigned to any independent movement(s) of traffic.</p> <p><b>Vehicular Phase</b> - A vehicular phase is a phase which is allocated to vehicular traffic movement as timed by the controller unit.</p>

Term	Meaning
Portion	<p><b>Extensible Portion</b> - That portion of the green interval of an actuated phase following the initial portion which may be extended, for example, by traffic actuation.</p> <p><b>Initial Portion</b> - The first timed portion of the green interval in an actuated controller unit:</p> <p><b>Fixed Initial Portion</b> - A preset initial portion that does not change.</p> <p><b>Computed Initial Portion</b> - An initial portion which is traffic adjusted.</p> <p><b>Maximum Initial Portion</b> - The limit of the computed initial portion.</p> <p><b>Minimum Initial Portion</b> - Refer to "Fixed Initial Portion"</p> <p><b>Added Initial Portion</b> - An increment of time added to the minimum initial portion in response to vehicle actuation.</p> <p><b>Interval Portion</b> - A discrete subdivision of an interval during which the signals do not change.</p>
Preemption	The transfer of the normal control of signals to a special signal control mode for the purpose of servicing railroad crossings, emergency vehicle passage, mass transit vehicle passage, and other special tasks, the control of which require terminating normal traffic control to provide the priority needs of the special task.
Preemptor, Traffic Controller	A device or program/routine which provides preemption.
Preferred Sequence	Normal order of phase selection within a ring with calls on all phases.
Progression	The act of various controller units providing specific green indications in accordance with a time schedule to permit continuous operation of groups of vehicles along the street at a planned speed.
Red Indication, Minimum (Red Revert)	Provision within the controller unit to assure a minimum Red signal indication in a phase following the Yellow change interval of that phase.
Rest	The interval portion of a phase when present timing requirements have been completed.
Ring	A ring consists of two or more sequentially-timed and individually-selected conflicting phases so arranged as to occur in an established order.

**Glossary**

▪ *Appendix T*

Term	Meaning
SDLC	<b>Synchronous Data Link Control</b> - A protocol for transfer of data between the controller, MMU and BIUs in a TS2 cabinet.
Signal	A device which is electrically-operated by a controller assembly and which communicates a prescribed action (or actions) to traffic.
Speed	The speed of vehicles passing a point in the roadway during a period in time. Typically expressed in Average Miles per Hour or Average Miles per Hour per Lane.
Split	The segment of the cycle length allocated to each phase or interval that may occur (expressed in percent or seconds). In an actuated controller unit, split is the time in the cycle allocated to a phase. In a pretimed controller unit, split is the time allocated to an interval.
Suppressors	<p><b>Suppressor, Radio Interference</b> - A device inserted in the power line in the controller assembly (cabinet) that reduces the radio interference.</p> <p><b>Suppressor, Transient</b> - A device which serves to reduce transient over-voltages.</p>
Switch	<p><b>Auto/Manual Switch</b> - A device which, when operated, discontinues normal signal operation and permits manual operation.</p> <p><b>Flash Control Switch</b> - A device which, when operated, discontinues normal signal operation and causes the flashing of any predetermined combination of signal indications.</p> <p><b>Power Line Switch (Disconnect Switch)</b> - A manual switch for disconnecting power to the controller assembly and traffic control signals.</p> <p><b>Recall Switch</b> - A manual switch which causes the automatic return of the right-of-way to its associated phase.</p> <p><b>Signal Load Switch</b> - A device used to switch power to the signal lamps.</p> <p><b>Signal Shut-Down Switch</b> - A manual switch to discontinue the operation of traffic control signals without affecting the power supply to other components in the controller cabinet.</p>
Terminals, Field	Devices for connecting wires entering the controller assembly.
Time Base Control	A means for the automatic selection of modes of operation of traffic signals in a manner prescribed by a predetermined time schedule.



Term	Meaning
Timing	<p><b>Analog Timing</b> - Pertaining to a method of timing that measures continuous variables, such as voltage or current.</p> <p><b>Concurrent Timing</b> - A mode of controller unit operation whereby a traffic phase can be selected and timed simultaneously and independently with another traffic phase.</p> <p><b>Digital Timing</b> - Pertaining to a method of timing that operates by counting discrete units.</p> <p><b>Timing Plan</b> - The Split times for all segments (Phase/Interval) of the coordination cycle.</p>
Transit Signal Priority (TSP)	<p>A special controller mode that operates when it detects a transit vehicle (bus). It maximizes throughput for both transit and private vehicles with no interruption of coordination and no omission of phases.</p>
Volume	<p><b>Actual</b> - The count of vehicles passing a point in the roadway during a period in time. Typically expressed in Vehicles per Hour or Vehicles per Hour per Lane.</p> <p><b>Scaled</b> - The percentage that the Actual Volume is when compared to a stated maximum. The stated maximum is considered to be 100% use of the roadway.</p>
Yield	<p>A command which permits termination of the green interval.</p>

### Abbreviations in Connector Pin Functions

For each page, the abbreviations in the table below are in alphabetical order down the left half of the table and then the order continues in the right half of the table.

Abbreviation	Meaning	Abbreviation	Meaning
ADD	address	EN	enable
ADV	advance	ENA	enable
CK	check	ENA 5 SEC HD CR	enable 5 section head control
CL	clear	EXT	external, extension
CNA	call to non-actuated	FL	flash
CON	control	GRN	green
CONT	control	GT	gate
COORD	coordination	IM	intersection monitor
CRC	cyclical redundancy check	IN	in
CRD	coordination	IND	indicator
CRD NOFLT FL	coordination no fault flash	INH	inhibit
CTR	controller	INTER	interval
CTR FAULT MON	controller fault monitor	INT-LCK	interlock
CTR VOLT MON	controller voltage monitor	KBD	keyboard
CYC	cycle	LK	link
DET	detector	LS	load switch
DIAG	diagnostics	MAN	manual
DIR	direction	MCE	manual control enable
DMAND	demand	MIN	minimum
DR1	detector rack #	MOD	modifier
DWALK	don't walk	MON	monitor
DWN	down	MON FL STAT	monitor flash status

Abbreviation	Meaning	Abbreviation	Meaning
MX	maximum	SPE FUNC	special function
NO FLT FL STAT	no fault flash status	SPL	special, split
NOW	now	ST	start time, stop time
NXT	next	ST TM	stop time
OL	overlap	STAT	status
OSET	offset	SW	switch, software
P-CL	pedestrian clear	SYNC	synchronous
PED	pedestrian	SYS	system
PH	phase	TBC	time-based control
PLN	plan	TK	track
PMT	preempt	TM	time
PMT CMU INTLK	preemptor CMU interlock	TMG	timing
PRI	priority	TP	timing plan
R	ring	TRM	terminate
RD	Read	TSP	transit signal priority
RECYC	recycle	TSP ACT	transit signal priority active
RST	rest, reset	WLK	walk
RX	receive	X ST SY	cross street synchronization
SEL	select	YEL	yellow
SL	slot		

---

**For your notes:**